

Editor's Note

This paper is the first in what we hope will become a series. "Classics Revisited" will appear periodically in the TRANSACTIONS; these papers will reevaluate the substance and importance of recognized classics, in terms of their impact on modern microwave technology. We expect that the tutorial value of these papers, and their documentation of the creative process in our technology, will make them very valuable to our readership.

This series was proposed by Dr. Gupta, so it is appropriate that he present the first paper. Others interested in preparing a paper in this series should contact the MTT editor or Dr. Gupta. Because such papers are part historical and part technical, only papers that exhibit a high degree of both technical and scholarly value will be accepted.

Power Gain in Feedback Amplifiers, a Classic Revisited

Madhu S. Gupta, *Fellow, IEEE*

Abstract—This paper is a tutorial review of a classic paper of the same title authored by Samuel J. Mason, and published in 1954. That paper was the first to define a unilateral power gain for a linear two-port, and to prove that this gain is invariant with respect to linear lossless reciprocal four-port embeddings, thereby making it useful as a figure of merit intrinsic to the device. The significance of the paper stems from the fact that (a) it introduced a new fundamental parameter that is now used to evaluate all three-terminal active devices, (b) it initiated work on a new line of inquiry, which has led to the discovery of many other invariants that describe the essential constraints on the behavior of networks, and (c) its results form the foundation for many of the basic ideas currently in use, including those of the cutoff frequency of transistors, activity of devices, stability of amplifiers, and device invariants. The present article brings that original paper up-to-date, presents a tutorial exposition of its contents in a modern form, and points out its significance and applications in microwave engineering. The subsequent advances in the subject area of the paper are also summarized so that the original paper can be placed within a broader context, and understood with a more general perspective.

I. INTRODUCTION

THIS PAPER is a tutorial review of a classic paper, having the title "Power Gain in Feedback Amplifiers," authored by Samuel J. Mason, and published in 1954 [1]. In that paper, Mason defined a unilateral power

gain for a linear twoport, and discussed some of its properties. The unilateral power gain U is the maximum power gain that can be obtained from the twoport, after it has been made unilateral with the help of a lossless and reciprocal embedding network (which provides the required feedback). Among the many interesting properties of U related to the frequency characteristics, activity, and stability of the twoport, perhaps the most important is the result due to Mason that U is invariant to a class of transformations (linear lossless reciprocal embeddings), and is therefore a characteristic inherent to the device. Consequently, U is useful as a figure of merit of the device, both by itself, and through other quantities that can be deduced from it. The title of Mason's paper does not fully indicate its contents and applicability.

Although Mason's paper originally appeared in a journal devoted to circuit theory, its results have been of most interest to the microwave device community. This is because in practice the value of the device power gain U becomes unimportant when U is either smaller than, or much larger than, unity; $U \geq 1$ happens to occur in the microwave frequency range for most state-of-the-art active devices of the last three decades.

The present paper is intended to be an exposition of both the subject matter of Mason's paper, as well as its applications and generalizations that have appeared in the subsequent work in this field. There are three parts to this paper. The first part is a tutorial explanation of the contents of Mason's paper, explaining the problem posed by

Manuscript received April 29, 1991; revised January 9, 1992.
The author is with Hughes Aircraft Company, Microelectronic Circuits Division, P.O. Box 240, M/S 235-1234, Torrance, CA 90509-2940.
IEEE Log Number 9107020.

Mason, his line of reasoning, and the results obtained. The second part of this paper points out the significance and utility of Mason's paper, in light of its later applications. The third part of this paper summarizes the advances in the search for network invariants that have been made since the appearance of Mason's paper; these advances constitute the framework within which Mason's results can be understood with a more general perspective.

II. MASON'S INVARIANT U

At the time of Mason's work in 1953, transistors were only five years old; were fabricated in germanium with alloyed junctions [2]; were the only successful solid-state three-terminal active device; were beginning to be developed for RF applications; and were limited to frequencies in and below the VHF range. According to the introduction in his paper [1], Mason was motivated by the desire to discover a figure of merit for the transistor. This search led him to identify the unilateral power gain of a linear twoport as an invariant figure of merit of a linear twoport.

A. Mason's Objective and Approach

As Mason's paper deduced a maximum invariant power gain, one might expect the starting point of the paper to be an expression for the power gain of a linear twoport, which is then maximized and proved to be invariant. (Such an approach can be found in some textbook treatments of the subject [3].) Instead, Mason begins the paper with a search for any arbitrary invariant network property that might happen to exist, and once it is found, identifies it as a power gain. His approach therefore not only finds the invariant power gain, but also demonstrates that the unilateral power gain is both inevitable and the only device characteristic that is invariant under a specified class of transformations.

Since the figure of merit of a device should be an inherent characteristic of the device, and not merely an artifact of its environment, it must be invariant with respect to some types of changes in the environment. Accordingly, Mason's stated goal in the paper is to look for a property of the linear twoport that is invariant with respect to a specified class of transformations. A complete statement of this problem should include both the specification of the device and its environment, as well as the types of changes in the environment of the device (the "transformations") under which the desired figure of merit is to remain invariant. Mason's paper therefore proceeds along the following major steps:

- (a) It stipulates the manner in which the device will be connected to its environment, and describes its behavior in terms of its twoport network parameters at a single frequency.
- (b) It represents a change in the device environment as an embedding network and defines the permissible changes through some constraints imposed on the embedding network.

- (c) It demonstrates that the permissible transformations can be made up from a set of just three elementary transformations.
- (d) It then deduces the form that a network property must have in order for it to be an invariant with respect to each of the three elementary transformations.
- (e) The resulting form is then found to be a power gain, applicable when the device has been embedded in a network that makes the embedded device unilateral.

B. Problem Definition

The object whose properties are under study is a linear twoport network, and will be called a "device" hereafter, in anticipation of the fact that the results will subsequently be applied to transistors and to other active devices. The device under consideration is constrained by three requirements:

- (a) It has only two ports (at which electrical power can be transferred between the device and the remainder of the universe).
- (b) It is linear (in the relationships that it imposes between the electrical currents and voltages at the two ports).
- (c) It is used in a specified manner (connected as an amplifier between a linear one-port source network and a linear one-port load) as shown in Fig. 1(a).

Since it is otherwise unrestricted, the device can be active or passive, lossy or lossless, reciprocal or non-reciprocal, symmetric or asymmetric, and spatially distributed or lumped.

Although the search for an invariant property of the device can be carried out in terms of any type of network parameters (such as the scattering parameters or impedance parameters), the impedance parameters will be used here, so as to retain the flavor of the original line of reasoning used by Mason. Let the open-circuit impedance matrix of the device be represented by Z .

Any transformation of the device environment can be conceptualized as an embedding network, as shown in Fig. 1(b), through which the two ports of the device are accessed. The permissible class of transformations can be defined in terms of constraints imposed on the embedding network. Mason defined the problem as being the search for device properties that are invariant with respect to transformations as represented by an embedding network satisfying the four constraints that it be (a) a four-port, (b) linear, (c) lossless, and (d) reciprocal.

C. Problem Solution

Mason next demonstrated that all permissible transformations that satisfy the above constraints can be synthesized from just three elementary transformations that are carried out sequentially; this is equivalent to representing any permissible embedding network by a set of three

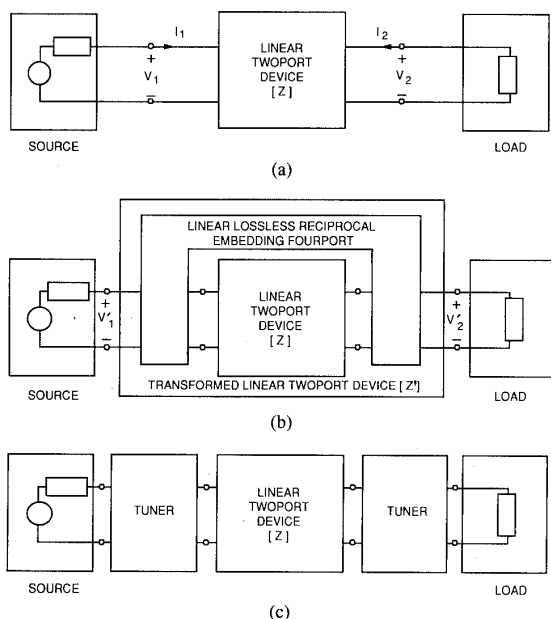

Fig. 1. The given linear twoport device. (a) Connected as an amplifier between the linear one-port source and load networks. (b) Embedded within a linear lossless reciprocal four-port. (c) Matched to the source and load through linear lossless reciprocal tuners.

embedding networks nested within each other. The elementary transformation are called reactance padding, real transformation, and inversion. In circuit terms, the three transformations can be described by the lossless embedding networks shown in Fig. 2. Mathematically, they can be defined by expressing the Z' matrix of the transformed device in terms of the Z matrix of the device prior to the transformation:

(a) Reactance Padding:

$$\begin{bmatrix} Z'_{11} & Z'_{12} \\ Z'_{21} & Z'_{22} \end{bmatrix} = \begin{bmatrix} Z_{11} + jx_{11} & Z_{12} + jx_{12} \\ Z_{21} + jx_{21} & Z_{22} + jx_{22} \end{bmatrix} \quad (1)$$

where all x_{ij} are real.

(b) Real Transformations:

$$\begin{bmatrix} Z'_{11} & Z'_{12} \\ Z'_{21} & Z'_{22} \end{bmatrix} = \begin{bmatrix} n_{11} & n_{12} \\ n_{21} & n_{22} \end{bmatrix} \begin{bmatrix} Z_{11} & Z_{12} \\ Z_{21} & Z_{22} \end{bmatrix} \begin{bmatrix} n_{11} & n_{21} \\ n_{12} & n_{22} \end{bmatrix} \quad (2)$$

where all n_{ij} are real.

(c) Inversion:

$$\begin{bmatrix} Z'_{11} & Z'_{12} \\ Z'_{21} & Z'_{22} \end{bmatrix} = \begin{bmatrix} Z_{11} & Z_{12} \\ Z_{21} & Z_{22} \end{bmatrix}^{-1} \quad (3)$$

The embedding networks shown in Fig. 2 are only illustrative and not unique; the above transformations can also be achieved by other embedding networks.

Mason's search for an invariant property of the device proceeds by inquiring as to the nature of the quantities

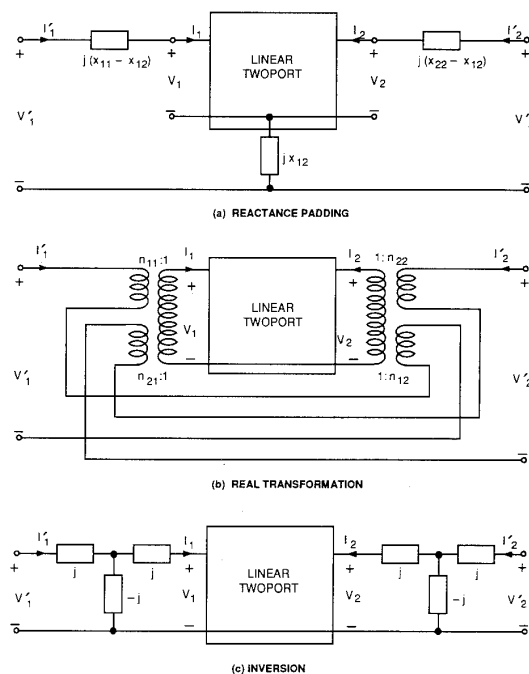

Fig. 2. The three elementary transformations that can synthesize an arbitrary linear lossless reciprocal four-port embedding.

that remain invariant under each of the three elementary transformations:

- (1) The reactance padding transformation leaves the following two matrices unchanged

$$[Z - Z_t] \text{ and } [Z + Z^*] \quad (4)$$

where t denotes matrix transposition, and $*$ denotes the complex conjugate. Indeed, all quantities left unchanged by this transformation are either the elements of these two matrices, or are functions thereof. Consequently, any property of the device that is invariant under the reactance padding transformation must be a function of only these two matrices.

- (2) The real transformation leaves unchanged the determinant of the matrix

$$[Z - Z_t][Z + Z^*]^{-1} \quad (5)$$

In fact, this determinant is the only function of the two matrices in (4) that has this property. As a result, the ratio of determinants

$$\frac{\det [Z - Z_t]}{\det [Z + Z^*]} \quad (6)$$

is invariant under both reactance padding and real transformations.

- (3) Finally, the inversion transformation leaves the magnitudes of the two determinants in the above ratio, and the sign of the one in the denominator, unchanged. Hence the quantity invariant under all

three elementary transformations is

$$U = \frac{|\det [\mathbf{Z} - \mathbf{Z}_t]|}{\det [\mathbf{Z} + \mathbf{Z}^*]} = \frac{|Z_{12} - Z_{21}|^2}{4 (\operatorname{Re} [Z_{11}] \cdot \operatorname{Re} [Z_{22}] - \operatorname{Re} [Z_{12}] \cdot \operatorname{Re} [Z_{21}])}. \quad (7)$$

The quantity U discovered in this manner is the desired invariant property of the device, and the principal result of Mason's paper.

D. Alternative Expressions for the Invariant

The form of U remains unchanged when it is expressed in terms of the admittance parameters of the two-port:

$$U = \frac{|Y_{21} - Y_{12}|^2}{4 (\operatorname{Re} [Y_{11}] \cdot \operatorname{Re} [Y_{22}] - \operatorname{Re} [Y_{12}] \cdot \operatorname{Re} [Y_{21}])}. \quad (8)$$

An expression for U in terms of the scattering parameter matrix S can be found [4] by substituting for the Z matrix the identity

$$\mathbf{Z} = (\mathbf{I} + \mathbf{S})(\mathbf{I} - \mathbf{S})^{-1} \quad (9)$$

where \mathbf{I} is a unit matrix. With this substitution,

$$U = \frac{|S_{12} - S_{21}|^2}{\det [\mathbf{I} - \mathbf{S}\mathbf{S}^*]}. \quad (10)$$

Still another useful form of the expression for U is in terms of the stability factor k , defined as

$$k = \frac{1 - |S_{11}|^2 - |S_{22}|^2 + |S_{11}S_{22} - S_{21}S_{12}|^2}{2|S_{12}S_{21}|}. \quad (11)$$

Since the stability of an active twoport is of prime importance, its k may already be known or determined; then U can be conveniently found from

$$U = \frac{|(S_{21}/S_{12}) - 1|^2}{2k|S_{21}/S_{12}| - 2 \operatorname{Re} [S_{21}/S_{12}]}. \quad (12)$$

III. THE SIGNIFICANCE OF MASON'S INVARIANT U

Having established that the quantity U in (7) is an invariant, following Mason, we next turn to identifying its physical significance. A physical meaning can be ascribed to U in a number of different ways: as a power gain maximum, as a measure of device activity, and as an invariant under a class of bilinear Möbius transformations. Each of these interpretations of U is examined below in detail.

A. U as a Gain Maximum

One interpretation of U is as a maximum of a power gain of the linear twoport device under some specific restrictive conditions. Consider the device embedded in a fourport network, as shown in Fig. 1(b), and used as an amplifier between a linear source network having a source

impedance Z_s and a linear load network having an impedance Z_L . Then, U is the maximum achievable value of the power gain of this amplifier, provided:

- 1) The embedding network is a linear lossless reciprocal fourport.
- 2) The embedded device (i.e., the composite of the given device and the embedding network) is unilateralized.
- 3) There is no other connection between the source and the load networks, except through the unilateralized device.
- 4) The source and load impedances Z_s and Z_L are passive, and are the variables with respect to which the gain is maximized.

In order to comprehend this interpretation of U , and the import of the restrictive conditions imposed in gain maximization, it is necessary to understand the concept of unilateralization first. This is discussed next.

1) *Unilateralization*: What is unilateralization? Unilateralization of a given linear twoport is the process of embedding the given device within an embedding network as shown in Fig. 1(b), such that the embedded device has no reverse transmission of signals, from the output port to the input port, i.e.,

$$Z'_{12} = 0 \quad (13)$$

where Z' is the open-circuit impedance matrix of the transformed device (i.e., the composite of the device and the embedding network), defined at the external ports of the embedding network.

How can unilateralization be carried out? A given device can be unilateralized in numerous ways, and the embedding network needed to unilateralize it is not unique. A number of different practical methods of unilateralization are discussed by Cheng [5], along with examples and uses of unilateralization for both electron tubes and transistors. For the sake of conceptual understanding, one possible method of unilateralization is shown in Fig. 3. In this method, the embedding network consists of just a reactance and an ideal transformer. As a result of its simplicity, the manner in which the unilateral nature of the transformed device comes about can be easily understood in this scheme. The added reactance at the output port brings about a phase change in the output voltage such that it is in phase (or exactly out of phase) with the input voltage when $I_1 = 0$. The turns ratio (and the polarity) of the transformer in the feedback path is then adjusted so that it introduces a voltage at the input port to cancel that due to the reverse transfer through the non-unilateral device. Mathematically, the reverse transfer impedance of the embedded device of Fig. 3 can be found as

$$Z'_{12} = Z_{12} - n(Z_{22} + jx_2). \quad (14)$$

This can be made to vanish by selecting x_2 so as to equate the angles of the two complex terms on the right hand side, and then selecting n to make their magnitudes equal.

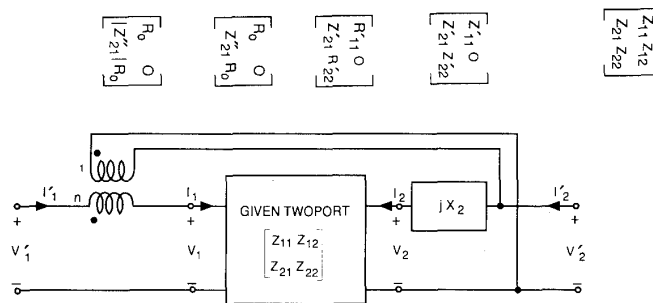

Fig. 3. One possible method of unilateralizing a given linear twoport by a linear lossless reciprocal four-port embedding.

Why is unilateralization worthy of attention? Unilateralization of a given linear twoport is useful both in practice and in concept. Amplifier designers often add feedback elements (i.e., an embedding network) to an active device so as to prevent a reverse traveling wave in a cascade of twoports, and so as to allow tuning or impedance matching to be carried out at the output port of the twoport without influencing the tuning or matching at the input port. Conceptually, unilateralization allows the twoport performance to be analyzed and understood more simply due to the decoupling of the input side network from the output side network.

2) *Gain Maximization after Unilateralization*: The interpretation of U as a gain maximum can now be understood. Consider the device embedded within a unilateralizing network that meets the specified conditions, as shown in Fig. 1(b), and let the open-circuit impedance matrix of the transformed device be represented by Z' . Since the transformed device is unilateral,

$$Z'_{12} = 0. \quad (15)$$

Consider next the power gain of the transformed device, operated between the source and the load networks. If the source and the load networks are varied for maximizing the power gain, their impedances will attain a value equal to the complex conjugate of the input and the output impedances of the device, respectively, provided both $\text{Re}[Z'_{11}]$ and $\text{Re}[Z'_{22}]$ are positive; i.e., the unilateralized device is absolutely stable. Under these conditions, the power gain is given by

$$U = \frac{|Z'_{21}|^2}{4 \text{Re}[Z'_{11}] \cdot \text{Re}[Z'_{22}]}. \quad (16)$$

But, from (7), this is also the value of Mason's invariant U for the transformed device under the condition (15). This establishes that the maximum power gain of the transformed device equals the U of the device. Moreover, since this argument holds for every lossless reciprocal embedding network, and since the U value is invariant to the embedding, every unilateralizing embedding must result in the same value of maximum power gain for the device, and this value is equal to the U of the device.

Under what conditions is the unilateralized device ab-

solutely stable [6] (i.e., the real parts $\text{Re}[Z'_{11}]$ and $\text{Re}[Z'_{22}]$ of its open-circuit input and output impedances are both positive)? It is clear by inspection that the embedding network of Fig. 3 leaves $\text{Re}[Z'_{22}]$ unchanged, and that $\text{Re}[Z'_{11}]$ and $\text{Re}[Z'_{22}]$ must have the same sign if U is positive. Therefore, if $\text{Re}[Z'_{22}]$ and U were known to be positive, an embedding network could be found that would make the device unilateral and absolutely stable. By moving the reactance jX_2 from the output port to the input port in Fig. 3, a similar conclusion can be reached if both $\text{Re}[Z'_{11}]$ and U are known to be positive. Finally, if $U > 1$, both $\text{Re}[Z'_{11}]$ and $\text{Re}[Z'_{22}]$ can be made positive regardless of the sign of $\text{Re}[Z'_{11}]$ and $\text{Re}[Z'_{22}]$. In conclusion, the necessary and sufficient conditions for the unilateralized device to be absolutely stable are as follows:

- (1) U is positive, and at least one of the two resistances $R_{11} = \text{Re}[Z'_{11}]$ and $R_{22} = \text{Re}[Z'_{22}]$ is positive; or
- (2) U is greater than unity (when neither R_{11} nor R_{22} is positive).

3) *Constraints Imposed in Gain Maximization*: The conditions imposed on the embedding network, under which U has been shown to be a gain maximum, are very important for the proper interpretation of U , since U is neither the only gain maximum that can be defined (i.e., other gain maxima also exist), nor the global or the highest maximum (i.e., power gain values higher than U can be achieved by proper embedding). These two statements are now briefly explained.

U is not the highest power gain that can be obtained from the device in an arbitrary circuit. Indeed, if the device is active ($U > 1$), the maximum power gain obtainable from the device is infinite, which is in evidence when the device is used in an oscillator circuit. The power gain of a linear twoport in a fourport embedding will necessarily have a finite maximum value with respect to the source and load impedances only under certain conditions, e.g., when the device is passive, or if active, it is absolutely stable and does not have a feedback path between the output and the input ports. It is clear that a gain maximum can be defined only if some restrictions are placed on the device and/or its embedding network.

Consider next the need for the conditions imposed on

the fourport embedding network in defining U . Each of the two constraints, of losslessness and reciprocity, is essential for defining a gain maximum for an active device in general. Indeed, Leine [7] shows by examples that if the embedding is lossless but not reciprocal, or if it is reciprocal but not lossless, the maximum power gain of the device in the circuit of Fig. 1(b) is unbounded if the device is active. The two constraints under which U is a maximum gain are thus also the minimum conditions for the existence of a finite power gain maximum when the device is embedded in an arbitrary fourport.

Finally, the importance of the unilateralization requirement can be demonstrated by a counter-example. In the special case where the fourport embedding network consists of two decoupled twoports, one at each port of the device, as shown in Fig. 1(c), the conditions for the existence of a gain maximum can be expressed entirely in terms of the device parameters, without imposing the requirements of losslessness and reciprocity on the embedding network. The stability factor k defined in (11) serves as a test of stability, and if its value at a given frequency is greater than 1, the device is absolutely stable, thereby ensuring that the maximum gain is finite. In this case, however, the maximum power gain (attained under simultaneous conjugate matched conditions at each port) is [8]

$$G_{\max} = (2U - 1) + 2\sqrt{U(U - 1)} \quad (17)$$

and this can be larger than U . In the limit of large U , this approaches the value $4U$. It is clear that U is not a gain maximum unless the device is first unilateralized by the embedding network.

4) *Other Gain Maxima*: A clearer understanding of the meaning and significance of the unilateral power gain U can be gained by comparing it with other kinds of power gain maxima determined under different conditions. A number of different power gain maxima have been defined in the literature, and are used in microwave work, from which Mason's unilateral power gain should be distinguished. These include the maximum available power gain G_{\max} [3], Rollet's maximum stable power gain G_{ms} [9], and Kotzebue's maximally efficient power gain G_{me} [10]. Their definitions and expressions are compared in Table I. The range of applicability and utility of these various power gain maxima are different. As an example, for many transistors at low frequencies, where Rollet's [9] stability factor $k < 1$, G_{\max} becomes infinite and is therefore defined only at higher frequencies where $k > 1$; the other three gain maxima of Table I exist even if $k < 1$. In particular, U is defined regardless of whether the device is active or passive, and absolutely stable or potentially unstable.

B. U as a Measure of Activity

The unilateral power gain U is not useful as a design goal or guideline, unless the active device is actually to be unilateralized. Its utility stems from the fact that U is

intimately related to the property of device activity. In fact, it not only serves as an indicator of activity in the device, but also as a quantitative measure of the device activity. This direct relationship with the property of activity makes U a quantity of fundamental importance.

The conditions under which a linear twoport device is active can be expressed in many different forms [6], and in terms of different network parameters. When expressed in the frequency domain, for real sinusoidal signals (i.e., at a single frequency $s = 0 + j\omega$ lying on the imaginary axis in the complex frequency plane), and in terms of the impedance matrix of the twoport at that frequency, the condition is as follows. The twoport is active if any of the following conditions holds [6]:

$$(1) R_{11} = \text{Re} [Z_{11}] < 0 \quad (18a)$$

$$(2) R_{22} = \text{Re} [Z_{22}] < 0 \quad (18b)$$

$$(3) \det [Z + Z_t^*] < 0. \quad (18c)$$

A device satisfying one (or both) of the first two conditions is said to have a "negative-resistance activity." By contrast, a device meeting only the third condition (and neither of the first two) is said to have a "transfer activity." The transfer active twoports are of particular importance because they form the backbone of electronics, and include such devices as triodes, pentodes, bipolar junction transistors, and field-effect transistors. We now show that the condition of transfer activity can be expressed entirely in terms of U as follows.

This condition, given in (18c), can be written in the following form after some algebraic simplification:

$$4(R_{11}R_{22} - R_{12}R_{21}) - |Z_{12} - Z_{21}|^2 < 0 \quad (19)$$

where R_{ij} denotes the real part of Z_{ij} . If the given device has no negative resistance activity after it has been unilateralized by a linear lossless reciprocal fourport embedding, it follows that

$$R'_{11} > 0 \quad \text{and} \quad R'_{22} > 0. \quad (20)$$

For such a device, Mason's unilateral gain U must necessarily be positive, since (16) shows that U is positive after unilateralization, and U is invariant to the embedding. But if $U > 0$, it follows from (7) that the first term on the left-hand side of (19) is positive; then the condition of activity in (19) can be written with the help of (7) as

$$U > 1 \quad (21)$$

The magnitude of U can therefore be used to test for the presence of transfer activity in a twoport. Moreover, if the U of a given device is a function of frequency (which is the case for all physical devices), the value of U can be used to identify the frequency range over which the device remains active.

C. U as a Canonical Property

One particularly illuminating method of understanding a characteristic property shared by all members of a set is

TABLE I
LINEAR TWOPORT POWER GAIN MAXIMA USED AS FIGURES OF MERIT

Symbol	Name	Definition or Conditions	Expression in Immittance Parameters	Expression in [S] Parameters
G_{ma}	Maximum Available Gain	Transducer gain ⁽¹⁾ G_T maximized with respect to Γ_G and Γ_L (or available gain with respect to Γ_L)	$\frac{ Y_{21}/Y_{12} ^2}{x + \sqrt{x^2 - 1}}$, where $x = \frac{2 \operatorname{Re} [Y_{11}] \operatorname{Re} [Y_{22}] - \operatorname{Re} [Y_{12} Y_{21}]}{ Y_{12} Y_{21} }$	$\left \frac{S_{21}}{S_{12}} \right (k \pm \sqrt{k^2 - 1})$
G_{ms}	Maximum Stable Gain	Device just stabilized [i.e., $k = 1$ obtained ⁽²⁾] by resistive loading; then G_T maximized with respect to Γ_G and Γ_L .	$\left \frac{Y_{21}}{Y_{12}} \right $	$\left \frac{S_{21}}{S_{12}} \right $
G_{mc}	Maximum Efficient Gain	Power gain ⁽³⁾ G reached when the power added by device (for a fixed input power) has been maximized with respect to Γ_L .	$\frac{ Y_{21} ^2 - Y_{12} ^2}{4 \operatorname{Re} [Y_{11} Y_{22}] - 2 \operatorname{Re} [Y_{12} Y_{21}] - 2 Y_{12} ^2}$	$\frac{\left \frac{S_{21}}{S_{12}} \right ^2 - 1}{2 \left(k \left \frac{S_{21}}{S_{12}} \right - 1 \right)}$
U	Unilateral Power Gain	G_T maximized with respect to Γ_G and Γ_L , after device has been unilateralized (i.e., $S_{12} = 0$ attained) by lossless reciprocal embedding.	$\frac{ Y_{12} - Y_{21} ^2}{4 (\operatorname{Re} [Y_{11}] \operatorname{Re} [Y_{22}] - \operatorname{Re} [Y_{12}] \operatorname{Re} [Y_{21}])}$	$\frac{\left \frac{S_{21}}{S_{12}} - 1 \right ^2}{2k \left \frac{S_{21}}{S_{12}} \right - 2 \operatorname{Re} \left(\frac{S_{21}}{S_{12}} \right)}$

$$^{(1)}\text{Transducer power gain } G_T([S], \Gamma_G, \Gamma_L) = \frac{(1 - |\Gamma_G|^2) |S_{21}|^2 (1 - |\Gamma_L|^2)}{|(1 - S_{11}\Gamma_G)(1 - S_{22}\Gamma_L) - S_{12}S_{21}\Gamma_G\Gamma_L|^2}$$

$$^{(2)}\text{Kurokawa's stability factor } k = \frac{1 - |S_{11}|^2 - |S_{22}|^2 + |S_{11}S_{22} - S_{12}S_{21}|^2}{2|S_{12}||S_{21}|}$$

$$^{(3)}\text{Power gain } G([S], \Gamma_L) = \frac{|S_{21}|^2 (1 - |\Gamma_L|^2)}{|1 - S_{22}\Gamma_L|^2 - |S_{11} - \Gamma_L(S_{11}S_{22} - S_{12}S_{21})|^2}$$

through the use of a canonical representation of the set. A canonical form for a class of networks is the clearest or simplest form, employing the least possible number of parameters, to which the given class of networks can be reduced by the allowed type of transformations, and which displays the common characteristics of the class, or the constraints imposed by them, in an easily understood way. Consider the set of all twoports that can be formed from the given twoport by linear lossless reciprocal transformations of the type shown in Fig. 1(b). A characteristic property of the set, established by Mason, is that every member of the set has the same unilateral power gain U . Since U is claimed to be the only invariant property of this set, it should be possible to develop a canonical network for the set with only one parameter. Such a "minimum" form for the above mentioned set of twoports is developed in this section. To keep the discussion intuitive, the following development employs the open-circuit impedance matrix of the twoports; an alternative approach employing scattering matrix is also available in the literature [11].

A linear twoport with a given impedance matrix can be represented by the equivalent circuit shown in Fig. 4(a). This twoport can be reduced to the canonical form shown in Fig. 4(f) through the use of linear lossless reciprocal transformations. The successive steps in this reduction are illustrated schematically in Fig. 4, and are as follows:

(i) As demonstrated in Section III-A, it is always pos-

sible to find a lossless reciprocal transformation which will make the twoport unilateral, as shown in Fig. 4(b). One such transformation is the feedback network of Fig. 3. The impedance matrix elements of the resulting unilateral twoport are given by

$$Z'_{11} = Z_{11} - (R_{12}/R_{22})Z_{21} \quad (22a)$$

$$Z'_{22} = Z_{22} + j[(R_{22}/R_{12})X_{12} - X_{22}] \quad (22b)$$

$$Z'_{21} = Z_{21} - Z_{12}. \quad (22c)$$

(ii) The imaginary parts of the two driving point impedances Z'_{11} and Z'_{22} can be reduced to zero by reactance padding at each of the twoports, which is also a lossless reciprocal transformation. As a result of this transformation, the two impedances become

$$R'_{11} = \operatorname{Re} [Z'_{11}] \quad (23a)$$

$$R'_{22} = \operatorname{Re} [Z'_{22}]. \quad (23b)$$

(iii) The twoport can be impedance matched to a desired real reference impedance R_o at both ports, with the help of a real transformer at each port, which is also a lossless reciprocal transformation. The only element of the impedance matrix that is left flexible after this transformation is

$$Z''_{21} = \frac{R_o}{\sqrt{R'_{11}R'_{22}}} Z'_{21}. \quad (24)$$

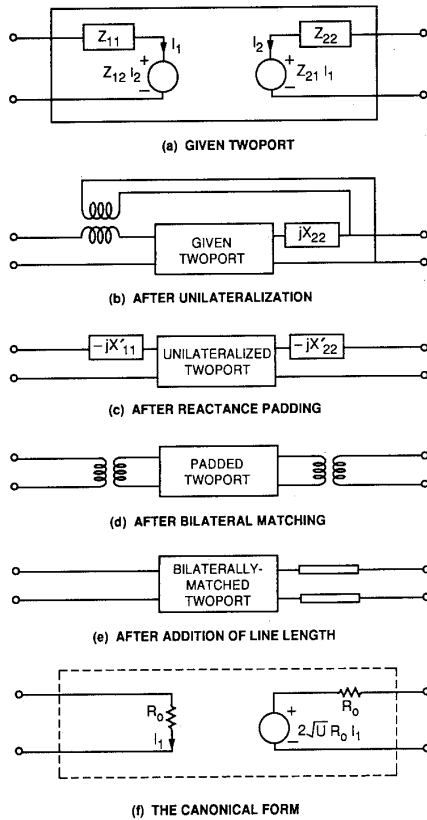

Fig. 4. Deduction of the canonical network for the set of twoports created by lossless reciprocal embeddings of a given twoport.

(iv) Finally, a lossless length of transmission line, having a characteristic impedance R_o can be added at either port, and its length adjusted, until the twoport has a real transfer impedance. The resulting twoport is the canonical form of Fig. 4(e), and has an impedance matrix

$$Z_c = \begin{bmatrix} R_o & 0 \\ |Z_{21}''| & R_o \end{bmatrix} \quad (25a)$$

where

$$Z_{21}'' = \frac{R_o |Z_{21} - Z_{12}|}{\sqrt{R_{11} R_{22} - R_{12} R_{21}}} = 2R_o \sqrt{U} \quad (25b)$$

which can be demonstrated with the help of (24) and (7). The canonical network of Fig. 4(f) is the circuit representation of the impedance matrix in (25). It is clear that the canonical form of the twoport requires only a single real parameter for its specification.

The canonical representation provides an alternative interpretation for Mason's invariant U of a given twoport. The scattering matrix of the canonical network can be found from the impedance matrix, and is given by

$$S_c = \begin{bmatrix} 0 & 0 \\ -\sqrt{U} & 0 \end{bmatrix}. \quad (26)$$

As might have been anticipated, if a given twoport is transformed, by a lossless reciprocal transformation, to a unilateral, phase-shift-less, matched twoport, matched at each port to a resistive reference impedance, the scattering matrix of the resulting twoport is completely described by the forward transfer function. By definition of scattering parameters, this transfer function is equal to the square-root of the unilateral power gain.

D. U as an Invariant of Bilinear Transformations

From a formal and abstract viewpoint, any embedding network can be viewed as simply a mathematical transformation applied to the terminal characteristics of the device embedded within it. The fact that the U of the embedded network does not change when the embedding device is restricted to be of certain types suggests the possibility that U may be interpreted as a geometrical or an algebraic property that is invariant under the class of mathematical transformations representing the permissible embeddings. Such an interpretation of U is described in this section. For clarity of exposition, the line of reasoning is presented here with emphasis on its essential elements and plausibility rather than on the highest possible rigor and generality. Accordingly, the twoport under consideration in this section may be assumed to be passive so as to avoid complications (e.g., twoport instability on matching, and reflection coefficients that lie outside the unit circle), although the results can be generalized.

1) *A Matched Circuit Model:* Bilateral impedance matching of a linear twoport consists in embedding the given twoport such that the embedded network has the following property: with either of its ports terminated in the reference impedance, the input impedance looking into the other port is equal to the same reference impedance. In practical applications of linear twoports, it is commonplace to attempt to carry out this impedance matching at each port without introducing either additional losses or nonreciprocal elements. Theoretically, a lossless reciprocal embedding network can always be found that will make the twoport bilaterally matched. Consider the given twoport embedded in one such matching network, as shown in Fig. 5(a). The bilateral matching of the twoport is most readily apparent when the twoport is described in terms of its scattering parameters (defined with respect to the same reference impedance at the two ports):

$$S = \begin{bmatrix} 0 & \rho_1 \\ \rho_2 & 0 \end{bmatrix} \quad (27)$$

where ρ_1 and ρ_2 are two complex numbers. This representation suggests a very simple equivalent circuit model for the matched twoport, shown in Fig. 5(b). This model employs an ideal fourport circulator and two oneports having reflection coefficients equal to the reverse and forward transmissions ρ_1 and ρ_2 of the matched twoport.

The unilateral gain U of the circuit model of Fig. 5(b) can be found by substituting the $[S]$ matrix elements from

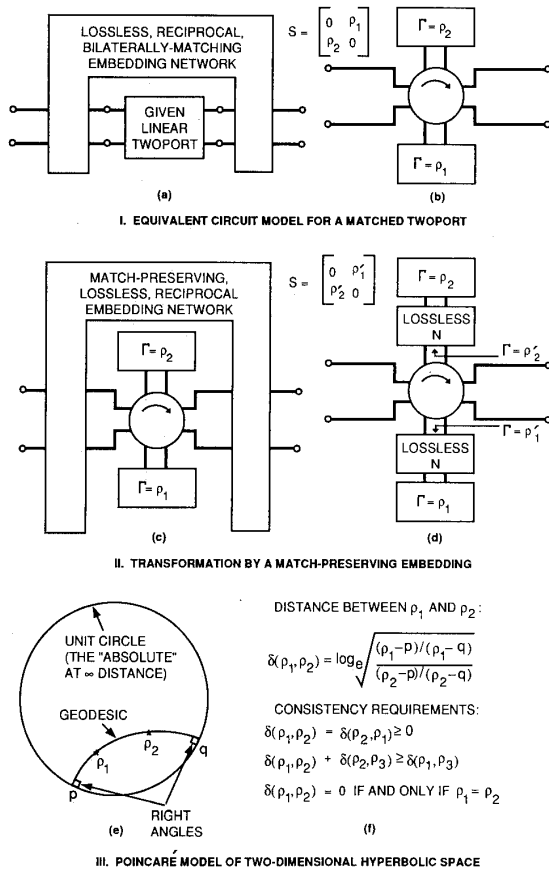

Fig. 5. Interpretation of U as a hyperbolic distance and a cross-ratio.

(27) into (10):

$$U = \frac{|\rho_2 - \rho_1|}{|1 - \rho_1^* \rho_2|} \quad (28)$$

This is then also the U for the given twoport, since the model differs from the original twoport only in respect of a lossless reciprocal embedding which leaves the U unchanged.

The matching network shown in Fig. 5(a) is, of course, not unique; as a result neither are ρ_1 and ρ_2 . Consider now the set of all bilaterally matched twoports that can be created from the given twoport by embedding it in different lossless, reciprocal fourport embedding networks. Since the inverse of a lossless reciprocal transformation is also a lossless reciprocal transformation, all twoports belonging to the set can be viewed as lossless reciprocal transformations of the matched twoport of Fig. 5(a), or that of its equivalent circuit model shown in Fig. 5(b). This is indicated in Fig. 5(c), which represents an arbitrary member of the set. Since each member of the set is bilaterally matched, it should also be possible to represent it by an equivalent circuit model of the type shown in Fig. 5(b), but with a different pair of reflection coefficients, say ρ'_1 and ρ'_2 . Indeed, the oneports having reflection coefficients

ρ'_1 and ρ'_2 can themselves be viewed as transformations of the oneports having reflection coefficients ρ_1 and ρ_2 , as shown in Fig. 5(d). Imposing the constraints of losslessness and reciprocity on the embedding network of Fig. 5(c) leads to the conclusion that a single lossless twoport can transform ρ_1 and ρ_2 into ρ'_1 and ρ'_2 respectively. The two twoports appearing in Fig. 5(d) are therefore identical.

We thus arrive at the crux of the argument. The circuit of Fig. 5(d) is a model for the given twoport, embedded as shown in Fig. 5(a), and a change in the embedding network causes a change in only the lossless twoports N , but not in ρ_1 and ρ_2 . Therefore, a function of the oneport reflection coefficients ρ_1 and ρ_2 , that is invariant to lossless embedding by N , is also an invariant of the given twoport under the permissible class of embeddings. Such an invariant function of ρ_1 and ρ_2 can be found by either a geometrical or an algebraic technique; both of these are described below in that order.

2) *A Geometrical Interpretation:* Prior to the advent of computer-aided circuit analysis and design software, impedance transformation and microwave circuit design calculations were often carried out with the help of graphical constructions, and many graphical aids, charts, and procedures were developed for this purpose. Some of these techniques are based on the use of concepts and results from non-Euclidean geometry. An introduction to the concepts of non-Euclidean geometry, and their applications in electrical engineering, will not be attempted here; a tutorial exposition [12] and a survey of applications [13] are available in the literature, and include citations to many other references. The following discussion is limited to the one result from hyperbolic geometry that is required for the present purposes.

Very briefly, a hyperbolic geometry is a non-Euclidean geometry in which Euclid's axiom of parallel lines is not employed, and the sum of the angles of a triangle does not equal 2π radians. As in any geometry, the distance between two points can be defined with some self-consistent metric, having the properties of additivity and a zero. In the Poincaré model shown in Fig. 5(e), the interior of a circle serves as the two-dimensional hyperbolic space, with the periphery (called the "absolute") being infinitely far. The geodesics (which, analogous to Euclidean "straight lines," are lines of shortest length between any two points on the lines) are circles that approach the absolute at right angles. The distance between two points is measured along the geodesic, and can be algebraically expressed as the logarithm of a ratio, as shown in Fig. 5(f). One of the basic results from this model is the invariance of the hyperbolic distance between two points.

The hyperbolic distance between two points can be given a circuit interpretation [14]. Let the two points in the complex plane be represented by complex numbers ρ_1 and ρ_2 , and consider two oneport networks having the reflection coefficients equal to ρ_1 and ρ_2 . Further suppose that a lossless twoport N is designed such that it transforms the first oneport to a perfectly matched load, i.e.,

the transformed reflection coefficient $\rho'_1 = 0$. If the same network N is used to transform the second oneport, its reflection coefficient will become ρ'_2 . The voltage standing wave ratio (VSWR) of this transformed oneport does not depend on the choice of N , and when expressed in some logarithmic unit such as dB or nepers, is the hyperbolic distance between ρ_1 and ρ_2 . This is given by

$$\delta(\rho_1, \rho_2) = \ln \frac{|1 - \rho_1^* \rho_2| + |\rho_1 - \rho_2|}{|1 - \rho_1^* \rho_2| - |\rho_1 - \rho_2|}. \quad (29)$$

In summary, if the complex numbers ρ_1 and ρ_2 represent reflection coefficients of two oneport networks, the hyperbolic distance $\delta(\rho_1, \rho_2)$ between them does not change when both oneports are transformed through the same lossless linear twoport. This basic result has been applied, and rediscovered, in numerous applications. For example, the figure of merit of two-state switching diodes [11], that is invariant to lossless transformations, is simply the hyperbolic distance between the impedances of the diode in its two states.

This result can now be applied to the circuit model of Fig. 5(d). Although ρ'_1 and ρ'_2 in this model are not unique, the hyperbolic distance between them is. Moreover, since the distance $\delta(\rho_1, \rho_2)$ is invariant to N , so is any function of δ ; in particular:

$$\tanh (\delta / 2) = \frac{|\rho_1 - \rho_2|}{|1 - \rho_1^* \rho_2|} \quad (30)$$

is independent of the matching network of Fig. 5(a). This is the same as the unilateral gain of (28). Thus U may be interpreted as a function of the hyperbolic distance between the forward and reverse transmissions of the bilaterally-matched twoport.

3) *An Algebraic Interpretation:* An algebraic interpretation is closely related to the above. The reflection coefficient ρ of a linear oneport, when viewed through an embedding linear twoport, undergoes a transformation of the form

$$\rho' = \frac{a\rho + b}{c\rho + d} \quad (31)$$

where $a, b, c,$ and d are four complex numbers, and are characteristics of the embedding twoport. If the transforming twoport is constrained to be lossless, the four complex numbers are also constrained, and the most general form that this transformation can take is as follows:

$$\rho' = \frac{\exp(j\alpha)\rho + A \exp(j\beta)}{A \exp[j(\alpha - \beta)]\rho + 1} \quad (32)$$

where A, α and β are all real constants. The reflection coefficients ρ'_1 and ρ'_2 in Fig. 5(d) can therefore be expressed in terms of ρ_1 and ρ_2 , and when these are substituted for ρ_1 and ρ_2 in the expression for unilateral gain given in (28), the value of U is found to remain unchanged.

A more general interpretation of U along the above lines is possible. A bilinear Möbius transformation [15] is a

mapping that takes a given complex number Z into another complex number W (the "image of Z ") given by

$$W = \frac{aZ + b}{cZ + d} \quad (33)$$

where a, b, c and d are complex constants. This is a commonly occurring transformation in the theory of linear networks, and the relationship between many pairs of quantities of interest takes this form, e.g., an impedance and the corresponding reflection coefficient, or the input impedance and the load impedance of a linear twoport. Supplemented by the convention that $W = a/c$ for $Z = \infty$, and $W = \infty$ for $Z = -d/c$, this transformation is both a conformal and a topological mapping of the extended plane onto itself, the topology being defined by distances on the Riemann sphere. Such a mapping is uniquely defined by specifying three distinct points in the Z plane, and their corresponding images in W plane (i.e., there is one and only one transformation for which this would be true).

The bilinear transformation has a number of remarkable geometrical properties, one of which is the invariance of the so-called "cross-ratio." The cross-ratio of four complex numbers $Z_1, Z_2, Z_3,$ and Z_4 is the image of Z_1 under a linear transformation which carries $Z_2, Z_3,$ and Z_4 into 1, 0, and ∞ (provided that $Z_2, Z_3,$ and Z_4 are distinct from each other). It is given by

$$C(Z_1, Z_2, Z_3, Z_4) = \frac{(Z_1 - Z_3)/(Z_1 - Z_4)}{(Z_2 - Z_3)/(Z_2 - Z_4)}. \quad (34)$$

The cross-ratio has some interesting properties; for example, it is real if, and only if, the four numbers $Z_1, Z_2, Z_3,$ and Z_4 lie on a circle. The one property of the cross-ratio relevant to the present discussion is its invariance under a bilinear transformation: if $W_1, W_2, W_3,$ and W_4 are the images of $Z_1, Z_2, Z_3,$ and Z_4 under the transformation in (33), then

$$\frac{(Z_1 - Z_3)(Z_2 - Z_4)}{(Z_1 - Z_4)(Z_2 - Z_3)} = \frac{(W_1 - W_3)(W_2 - W_4)}{(W_1 - W_4)(W_2 - W_3)}. \quad (35)$$

The hyperbolic distance defined in Fig. 5(f) is in fact based on a cross-ratio.

An embedding network can be viewed as a bilinear transformation [16], and Mason's U as a special case of the cross-ratio. A proof of this statement, presented in a more general setting, is contained in Section V-A below.

IV. APPLICATIONS OF MASON'S INVARIANT U

The results of Mason's paper have been employed in numerous ways since their publication. The first application, which originally motivated the work, was to the bipolar junction transistor, an active device then in its infancy. When biased in its active region, and operated under small-signal conditions, this device could be represented by a linear twoport, so that a bias and frequency dependent U could be defined for it. Several authors determined the unilateral power gain of the early germanium

transistors as a function of frequency, discussed the effect of various transistor equivalent circuit elements on the value of U , and thus deduced the limitations on the range of frequencies over which the transistors could be employed as active devices [17], [18]. Some of these applications are described in this Section.

A. U as a Figure of Merit

Prior to Mason's discovery of the invariant U , and for sometime thereafter until the importance of U was widely recognized, there was general uncertainty about the choice of a measure of device performance that should be used to describe the capability of a device in delivering power at high frequencies. As an example of this uncertainty, in the early work on bipolar junction transistors, a number of different types of power gains were used to evaluate the high-frequency performance of the device, including maximum available power gain [19], and the maximum attainable power gain when the source impedance is constrained to be purely resistive [18]. When used as a device figure of merit, these parameters have a number of limitations; e.g., they are influenced by conditions external to the device, and they depend on the manner in which the transistor is connected in the circuit (e.g., common-base versus common-emitter). The invariant U provided the device designers with a fundamental criterion for judging the goodness of a device. Moreover, since a common-emitter connection can be transformed into a common-base connection simply by embedding the former within a lossless reciprocal network composed of wires, U is invariant with respect to the method of connection, and serves as a more useful measure of device performance. An alternative proof of the invariance of U to the choice of input and output terminals may be given in terms of the indefinite admittance matrix [20].

Perhaps the most convincing evidence of the utility of the concept of a unilateral power gain as a device figure of merit is the fact that for the last three decades practically every new active twoport device developed for high-frequency use (and some passive ones as well [21], [22]) have been carefully scrutinized for the achievable value of U , the frequency dependence of U , the influence of device parameters on U , and the design techniques for enhancing the device U . Published accounts of these efforts include the analysis of:

- 1) Bipolar junction transistors by Statz, *et al.* [17];
- 2) Transit-time transistors by Zuleeg and Vodicka [23];
- 3) Junction FET's by Das and Schmidt [24];
- 4) Silicon MOSFET's by Burns [25];
- 5) Dual-gate MOSFET's by Burns [25];
- 6) GaAs MOSFET's by Mimura, *et al.* [26];
- 7) Microwave Silicon MESFET's by Baechtold and Wolf [27];
- 8) GaAs MESFET's by Bechtel, *et al.* [28];
- 9) HEMT's by Vickers [29]; and
- 10) Hetero-junction Bipolar transistors by Prasad, *et al.* [30].

Since the U was recognized as an important figure of merit of the device, its measurement was necessary for comparing the transistors, and for measuring the progress in their design. Accurate methods for the measurement of U were therefore developed, and the measurements were employed in the characterization of the transistors [31]. There are two different ways of determining the unilateral power gain of a given device at a specified frequency: one is by a direct experimental measurement in which a device is unilateralized and its power gain is experimentally maximized, and the other is by computation from the measured network parameters of the device. The former method is now obsolete, and the measurement of U for high-frequency devices is now almost invariably carried out with the help of an automatic network analyzer. The measured scattering parameters of the transistor can be used to determine the U in two different ways: either by a direct substitution of the network parameters in the expression for U given in (10), or by first fitting the measured parameters to a device equivalent circuit, from which U can be calculated in terms of the fitted values of the circuit elements appearing in the equivalent circuit. The agreement between the two possible estimates of U depends on the degree of fit (i.e., on the accuracy of the measured data, and the validity of the equivalent circuit).

Despite the fact that U is a more fundamental and elegant measure of active device capability, it is not used as widely in the electron device community as some of the other figures of merit, particularly the maximum available gain G_{ma} (e.g., [32]). There are several reasons for this:

- (a) For many devices and conditions, the values of U and G_{ma} are not far from each other [33]. This small difference is especially unimportant when the gain is large.
- (b) All power gains are equally easy to calculate from the immittance or scattering parameters. But when they are determined directly from an equivalent-circuit model of the device, U is less obvious due to the need to unilateralize the model.
- (c) In some cases, U is not the most convenient or practical parameter. For example, if the twoport under consideration is a frequency converter, the unilateralizing circuit must also be a frequency converter so that the feedback is compatible. Such a feedback circuit is easier to use in thought experiments [34] than in laboratory experiments.

B. U as an Indicator of Activity

A related application of the idea of U has been in clarifying the conceptual problems. The direct relationship of U to activity helps identify a passive network, or constrain the kind of performance expected from it. One example of the kind of misunderstanding that can be cleared through the use of U is given in [8], where Singhakowinta and Boothroyd [8] showed how to avoid a misunderstanding caused by earlier authors who had treated an unrealizable feedback network as passive.

C. Definition of f_{\max}

An evaluation of the relative power gain capability of two active devices requires, in general, a comparison of their U values over the entire frequency range of interest, since the unilateral power gain U is a function of frequency. (Only if the nature of the frequency dependence of $U(f)$ is known in advance, or is restricted, for example by confining the consideration to a single type of active devices, it may be sufficient to compare devices on the basis of their U values at just one frequency.) Clearly, it would be convenient and desirable to have a single-number measure of the quality of active devices. Such a simple, and highly practical, figure of merit can be derived from the unilateral gain $U(f)$, and is called the maximum oscillation frequency f_{\max} ; it is defined as the frequency at which U becomes unity, i.e.,

$$U(f)|_{f=f_{\max}} = 1 \quad (36)$$

If the unilateral power gain is a monotonic function of frequency, as is usually the case, f_{\max} is a well-defined, single-valued parameter. It is commonly used as a measure of the high-frequency capabilities of an active device. Its significance follows from the property of U expressed in (21) (that U exceeds unity for an active device). The maximum frequency of oscillations is therefore also the maximum frequency of activity.

The concept of a highest frequency above which power gain cannot be obtained from an active device, that had long been known from practical experience, thus became established on firm theoretical grounds with Mason's work, and was discussed in the literature immediately thereafter [17]. The first explicit mention of the f_{\max} in the literature appears to be due to P. R. Drouilhet [35], who defined it, deduced an expression for it, and measured it for transistors.

The value of f_{\max} also serves as a benchmark, indicating the level of development of active device technology. Thus, the state-of-the-art values of f_{\max} were of the order of 10^9 in the 1950s, of the order of 10^{10} in the 1970's, and are of the order of 10^{11} in the nineties.

In principle, there are three different methods of measuring the f_{\max} for a given two-port active device. The most direct, and conceptually the simplest, is the one in which the device is embedded in an oscillator circuit, with the input and output circuits incorporating a tuner (a low-loss two-port with variable impedance matrix), and attempts are then made to produce oscillations in the circuit at as high a frequency as possible. The accuracy of this manual method is dependent on the losses in the tuners, and the sensitivity with which the presence of a oscillations can be detected against the background noise. A more modern and efficient method of f_{\max} measurement is through the use of an automatic network analyzer, which typically yields S parameters of the two-port; then the unilateral power gain can be calculated as function of frequency from the measured S parameters by (10), and the frequency at which it drops to unity can thus be found.

Another commonly used method utilizes the measured S parameter data to deduce the values of the circuit elements in an equivalent circuit of the device by a numerical best-fit; the maximum available gain of the device is then calculated from the equivalent circuit, and the frequency at which it drops to unity can be calculated in terms of the equivalent circuit elements. If the equivalent circuit is physically based, this method allows extrapolation of the results to higher frequency; the need for this is explained below. If the measurement and circuit modeling errors are small, the results obtained by the various methods can be in good agreement, as demonstrated for MESFET's [27] and HBT's [36].

An accurate measurement of U as a function frequency, in the neighborhood of the high frequencies where it is unity, has always been difficult for state-of-the-art devices. (The f_{\max} for modern transistors lies in the mm-wave and sub-mm wave range, where there are no accurate automatic network analyzers; and even in the earlier decades, when the f_{\max} values were lower, so were the capabilities of the contemporary instrumentation.) As a result, the reported values of f_{\max} for transistors are often based on the measurement of U as a function of frequency over a range of frequencies (typically, well below f_{\max}), and then an extrapolation of the U to higher frequencies. The extrapolation implies an *a priori* knowledge of the nature of frequency variation of U , usually based on the physical reasoning or a known equivalent circuit for the device [37].

Interestingly, the frequency at which U attains the value of 1 is also the frequency at which the maximum stable gain G_{ms} and the maximum available gain G_{ma} of the device also become unity. As a result, alternative interpretations can be given to the quantity f_{\max} . More important, it is not necessary to measure $U(f)$ in order to determine f_{\max} ; one of the other gains can be used if it is easier to measure (and more reliably extrapolate). Many of the earlier papers on this subject [33], [38], [39] either state, or imply through graphical plots, that the frequency at which U becomes unity is higher than the ones at which G_{ms} or G_{ma} become unity. This notion is incorrect, and a formal proof of their equality has been published [40].

Several different cutoff frequencies of active devices (and in particular transistors) have been discussed in the literature. In addition to f_{\max} , these include the lowest (or dominant) pole frequency in the device transfer function; the low-pass cutoff frequency of an R - C network at the input or the output port of the device; a cutoff frequency due to phase delay (e.g., caused by the carrier transit-time in the device); the unity short-circuit current gain frequency f_T [41]; and the highest natural frequency of a network with multiplicity of active devices. The f_{\max} is a fundamental characteristic of the device, and has the physical significance that it is the maximum frequency of oscillation in a circuit in which the following three conditions are met: (i) there is only one active device present in the circuit, (ii) the device is embedded in a passive network, and (iii) only single sinusoidal signals are of interest.

If these conditions are not met, a device may be made to produce oscillations at frequencies higher than f_{\max} , and it is possible to define other cutoff frequencies that are variants of f_{\max} . For example, in integrated circuits, it is commonplace to have multiple active devices, or equivalently, an active device embedded in an active network. In such circuits, a more useful measure of the high-frequency capability of the device may be the power transfer cutoff frequency f_{PT} [42], which is the frequency of unity power gain with no unilateralization and with a load consisting of another identical device. Still another cutoff frequency suitable in integrated circuits is the maximum frequency of oscillation achievable in a circuit in which multiple identical copies of the device are permitted. Such a generalization of f_{\max} has been discussed in the literature [43].

V. GENERALIZATIONS OF U : OTHER NETWORK INVARIANTS

Invariant properties of networks are interesting and important because an invariant parameter that is a characteristic of the network can be put to many uses. One possible use of an invariant parameter is as a figure of merit of the network, that can serve as a basis for comparing different networks, for quantifying the change in a network caused by some design modification, and for measuring the progress towards a design goal. A second potential use of an invariant parameter is as a reference or a benchmark value that can be used to check the accuracy of a computation, modeling, or measurement of the network characteristic, by verifying whether the value of the parameter has remained unchanged. A third use of invariants is in identifying the limitations to the performance of a network, establishing the bounds on attainable characteristics, and determining the feasibility of some design goal. As a result of their utility, many different invariant properties of networks have been discovered over the years.

All known invariant parameters of networks can be classified into two groups based on the manner in which they are deduced [44]. One group, called "quasi-power invariants," consists of quantities that have the dimensions of power, or are functions thereof. Such invariants can be deduced from Tellegen's theorem, or from a more general matrix constraint expressing the linear time-invariance of the embedding network.

The second group of invariants consists of dimensionless quantities that follow from the cross-ratio invariance property [16] of bilinear transformations, or from its matrix generalization [44]. Mason's U is only one, and the earliest discovered, of the dimensionless invariants of the cross-ratio type. Other invariants of this type can be viewed as generalizations of Mason's invariant U , and are introduced here briefly.

Mason's method of search for the invariant property of the twoport not only proves that U is an invariant, but also simultaneously establishes that it is the only invariant

meeting the stated specifications. Therefore, the search for still other network invariants is futile unless the specifications of the problem are changed. One way of changing the problem specification is by relaxing one or more of the constraints imposed on the device and the embedding network in Mason's work. Mason's statement of the problem of network invariant search, given in Section II-B, contains the following constraints:

- (a) that the device has exactly two ports;
- (b) that the network parameters of the device are constant (i.e., the device is time-invariant);
- (c) that the embedding network is necessarily lossless and reciprocal; and
- (d) that the embedding network has four ports (i.e., the number of ports of the device remains unchanged upon embedding).

Network invariants can be found without some (or all) of these constraints, and the resulting invariants can be viewed as generalizations of Mason's U . Interestingly enough, some of these invariants had already been discovered independently, and out of necessity in some applications, before a more systematic search for them was undertaken [45]. A number of these invariants, such as those for characterizing the switching devices and the high- Q varactors, find applications in microwave engineering. The possibility of still other extensions and variations of Mason's invariant problem, based on network parameters other than impedance matrices, or broadband constraints, or nonlinear networks, or transfer rather than driving point functions, have also been briefly discussed in the literature [45], [46].

A. Generalization to n -Ports

In the problem of Section II-B, if the device under consideration is taken to be an n -port, and the linear lossless reciprocal embedding network is simultaneously allowed to be a $2n$ -port, an invariant generalized power gain can be deduced.

As a generalization of the cross-ratio of four complex numbers, given in (34), one can define a cross-ratio of four $n \times n$ matrices \mathbf{Z}_1 , \mathbf{Z}_2 , \mathbf{Z}_3 , and \mathbf{Z}_4 , which is another $n \times n$ matrix given by

$$\mathbf{R} = [\mathbf{Z}_1 - \mathbf{Z}_2][\mathbf{Z}_1 - \mathbf{Z}_3]^{-1} [[\mathbf{Z}_4 - \mathbf{Z}_2][\mathbf{Z}_4 - \mathbf{Z}_3]^{-1}]^{-1}. \quad (37)$$

The four given matrices can be thought of as the open-circuit impedance matrices of four different n -port linear networks. Consider now a $2n$ -port linear embedding network, that transforms each of the four conceptualized n -ports into another n -port, having open-circuit impedance matrices \mathbf{Z}'_1 , \mathbf{Z}'_2 , \mathbf{Z}'_3 , and \mathbf{Z}'_4 ; the cross-ratio of the transformed matrices is then found to be

$$\mathbf{R}' = \mathbf{H}\mathbf{R}\mathbf{H} \quad (38)$$

where \mathbf{H} is an $n \times n$ matrix whose elements obviously depend on the embedding network. Such a transformation

of \mathbf{R} to \mathbf{R}' is called a similarity transformation, and it leaves some of the characteristics (such as the eigenvalues) of the cross-ratio matrix \mathbf{R} unchanged. One of the unchanged characteristics is the value of the determinant of \mathbf{R} ; i.e.,

$$\det [\mathbf{R}'] = \det [\mathbf{R}] = \frac{\det [\mathbf{Z}_1 - \mathbf{Z}_2] / \det [\mathbf{Z}_1 - \mathbf{Z}_3]}{\det [\mathbf{Z}_4 - \mathbf{Z}_2] / \det [\mathbf{Z}_4 - \mathbf{Z}_3]} \quad (39)$$

regardless of the transforming matrix \mathbf{H} (and hence the embedding network).

This invariance property in (39) can be employed to develop many network invariants (that are invariant to the transformation through the $2n$ -port embedding network) by appropriate choice of the four given impedance matrices. For instance, if only one n -port, having an impedance matrix \mathbf{Z} , is of interest, the four required impedance matrices $\mathbf{Z}_1, \mathbf{Z}_2, \mathbf{Z}_3,$ and \mathbf{Z}_4 can be taken to be $\mathbf{Z}, \mathbf{Z}_r, -\mathbf{Z}^*$, and $-\mathbf{Z}_r^*$, respectively. With these four impedances, the invariant in (39) becomes

$$\det [\mathbf{R}] = \frac{|\det [\mathbf{Z} - \mathbf{Z}_r]|^2}{(\det [\mathbf{Z} + \mathbf{Z}_r^*])^2}. \quad (40)$$

This quantity is an invariant of the given n -port. When applied to the special case of a two-port, it reduces to the square of Mason's U function given in (7). Since the four selected impedance matrices can be generated from the given \mathbf{Z} by the successive application of two transformations $\mathbf{Z} \rightarrow \mathbf{Z}_r$ and $\mathbf{Z} \rightarrow -\mathbf{Z}^*$, and these two transformations commute with the $2n$ -port embedding provided the embedding is lossless and reciprocal, not only the numerical value of the $\det [\mathbf{R}]$ but also its functional form are preserved under the transformation by such an embedding network.

If the four impedances were selected in a different order, as $\mathbf{Z}, \mathbf{Z}_r, -\mathbf{Z}_r^*$, and $-\mathbf{Z}^*$, the invariant determinant becomes

$$\frac{|\det [\mathbf{Z} - \mathbf{Z}_r]|^2}{(\det [\mathbf{Z} + \mathbf{Z}_r^*])^2} \quad (41)$$

This invariant has also been derived earlier by other methods [45]. Still other invariants can be found by other choices of the four impedance matrices.

B. Generalization to Time-Varying Networks

It has been assumed throughout the above discussion that the properties of the device are time-invariant. In engineering practice, there are numerous instances in which a device is expected to perform as a linear network, but with different parameter values at different times. Examples of such devices are electronic switches, control circuits, and parametric devices. In each case, the network parameters of the device are made to vary in a controlled manner (or in response to a control signal), either between two or more distinct values (as in a switch), or continuously with time (as in a parametric device). Many in-

variants of such networks can be found in a manner that is a generalization of Mason's method, and some of them have a useful physical or practical significance.

Perhaps the simplest example of such an invariant is the figure of merit of a switching diode and has been mentioned in Section III-D. If the device under consideration is a linear oneport, and is capable of existing in two different states having impedances $\mathbf{Z}_1 = \mathbf{R}_1 + j \cdot \mathbf{X}_1$ and $\mathbf{Z}_2 = \mathbf{R}_2 + j \cdot \mathbf{X}_2$, the figure of merit is defined as

$$Q = \frac{|\mathbf{Z}_1 - \mathbf{Z}_2|}{2\sqrt{\text{Re} [\mathbf{Z}_1] \text{Re} [\mathbf{Z}_2]}}. \quad (42)$$

It is a measure of the separation between the impedance values of the diode in the two states, and serve as a measure of the usefulness of the diode as a switching element [47].

The procedure for deducing the invariants is a direct application of the general procedure described in Section V-A, along with an appropriate choice for the four impedance matrices needed to form the cross-ratio of (37). As the simplest case, consider an n -port linear network that can exist in two discrete states, and has the open-circuit impedance matrices \mathbf{Z}_1 and \mathbf{Z}_2 in the two states. One possible method of generating the four required matrices is through the use of a transformation, such as $\mathbf{Z} \rightarrow -\mathbf{Z}^*$. Then the four matrices are $\mathbf{Z}_1, \mathbf{Z}_2, -\mathbf{Z}_1^*$, and $-\mathbf{Z}_2^*$ respectively, and the invariant determinant becomes

$$\frac{|\det [\mathbf{Z}_1 - \mathbf{Z}_2]|^2}{\det [\mathbf{Z}_1 + \mathbf{Z}_1^*] \cdot \det [\mathbf{Z}_2 + \mathbf{Z}_2^*]}. \quad (43)$$

This invariant, specialized to the case of a scalar impedance Z (i.e., a 2-state, one-port linear device) is identical with Kurokawa's "quality factor for switching diodes." Once again, other invariants can be found by alternative choices of the four impedance matrices. For instance, a mere reordering of the four matrices as $[\mathbf{Z}_1], [\mathbf{Z}_2], [-\mathbf{Z}_2^*]$ and $[-\mathbf{Z}_1^*]$ results in the invariant

$$\frac{\det [\mathbf{Z}_1 - \mathbf{Z}_2]}{\det [\mathbf{Z}_1 + \mathbf{Z}_2^*]}. \quad (44)$$

Alternatively, if the matrices \mathbf{Z}_3 and \mathbf{Z}_4 are generated through the transformation $\mathbf{Z} \rightarrow -\mathbf{Z}_r^*$ applied to the given matrices \mathbf{Z}_1 and \mathbf{Z}_2 respectively, the resulting invariant in (39) would be

$$\frac{\det [\mathbf{Z}_1 - \mathbf{Z}_2]}{\det [\mathbf{Z}_1 + \mathbf{Z}_{2r}^*]}. \quad (45)$$

Both of these invariants, in (44) and (45), when applied to one-ports, encompass Kawakami's invariant [48].

Generalization of the above method to 3-state and 4-state networks is straightforward by using the corresponding impedance matrices. An extension to p -state network for $p > 4$ is also possible, by defining cross-ratio matrices \mathbf{R} for four matrices at a time, and then forming a chain of \mathbf{R} matrices [45]. This would yield n invariants of the p -state n -port network. Finally, if the impedance matrix of the n -port is a continuous function of some pa-

parameter, the set of discrete states can be conceptually replaced by a continuum.

C. Generalization to Other Embeddings

It is not necessary that the number of ports of the device remain unchanged when it is embedded; i.e., the embedding network for an n -port device need not have exactly $2n$ ports. If the embedding has a larger number of ports, the given n -port device can be conceptually enlarged by adding disjointed ports with short-circuits at those ports. When the embedding has fewer than $2n$ ports, the reduction in the number of ports causes the invariants to be replaced by constraints, expressed as inequalities among the moduli of eigenvalues of some matrices related to the cross-ratio. Some details of this approach can be found in the literature [45].

BIOGRAPHICAL NOTE

SAMUEL J. MASON (1921–1974)

Samuel J. Mason was born in New York City, and graduated from Rutgers University in 1942, received a Master's degree in 1947, and a Doctorate in 1954, both from MIT. In 1942, he joined MIT Radiation Laboratory, which after the second World War became the MIT Research Laboratory of Electronics, and he became the Associate Director of the Laboratory in 1967, a position he held until the time of his death in 1974. He was also a faculty member in Electrical Engineering, becoming an Assistant Professor in 1949, an Associate Professor in 1954, a Professor in 1959, and the Cecil H. Green Professor in 1972. He was a Fellow of the IEEE. His work in circuits and systems led to his major involvement in curriculum revision at MIT in the late 1950's, and he authored three textbooks on related subjects. During the later part of his career, his research interests turned to optical character recognition. Some of his best known contributions are in the areas of signal flow graph analysis (Mason's rule) and device invariant (Mason's Unilateral gain).

REFERENCES

- [1] S. J. Mason, "Power gain in feedback amplifiers," *Trans. IRE Professional Group on Circuit Theory*, vol. CT-1, no. 2, pp. 20–25, June 1954. (This work was previously reported in Tech. Rep. No. 257, Research Laboratory of Electronics, MIT, Cambridge, MA, 1953).
- [2] *Proc. IRE*, Special Issue on Transistors, vol. 40, no. 11, Nov. 1952.
- [3] W.-K. Chen, *Active Network and Feedback Amplifier Theory*. New York: McGraw-Hill, 1980, ch. 3.
- [4] W. H. Ku, "Unilateral gain and stability criterion of active two-ports in terms of scattering parameters," *Proc. IEEE*, vol. 54, no. 11, pp. 1617–1618, Nov. 1966.
- [5] C. C. Cheng, "Neutralization and unilateralization," *IRE Trans. Circuit Theory*, vol. CT-2, no. 2, pp. 138–145, June 1955.
- [6] E. S. Kuh and R. A. Rohrer, *Theory of Linear Active Networks*. San Francisco: Holden-Day, 1967, ch. 5.
- [7] P.-O. Leine, "On the power gain of unilateralize active networks," *IRE Trans. Circuit Theory*, vol. CT-8, no. 3, pp. 357–358, Sept. 1961.
- [8] A. Singhakowinta and A. R. Boothroyd, "On linear twoport amplifiers," *IEEE Trans. Circuit Theory*, vol. CT-11, no. 1, p. 169, Mar. 1964.
- [9] J. M. Rollet, "Stability and power gain invariants of linear two-ports," *IRE Trans. Circuit Theory*, vol. CT-9, no. 1, pp. 29–32, Mar. 1962.
- [10] K. L. Kotzebue, "Maximally efficient gain: a figure of merit for linear active twoports," *Electron. Lett.*, vol. 12, no. 19, pp. 490–491, Sept. 1976.
- [11] T. Schaug-Petersen and A. Tonning, "On the optimum performance of variable and nonreciprocal networks," *IRE Trans. Circuit Theory*, vol. CT-6, no. 2, pp. 150–158, June 1959.
- [12] D. J. R. Stock and L. J. Kaplan, "Non-Euclidean geometrical representations for microwave networks, Parts I and II," *Microwave J.*, vol. 5, no. 3, pp. 99–105, Mar. 1962, and vol. 5, no. 4, pp. 114–120, Apr. 1962.
- [13] E. F. Bolinder, "A survey of the use of non-Euclidean geometry in electrical engineering," *J. Franklin Inst.*, vol. 265, no. 3, pp. 169–185, Mar. 1958.
- [14] International Telephone and Telegraph Corp., *Reference Data for Radio Engineers*, 4th ed., New York: ITT, 1956, pp. 652–653.
- [15] E. G. Phillips, *Functions of a Complex Variable*. London: Oliver & Boyd, 1963.
- [16] T. E. Rozzi, J. H. C. van Heuven, and A. Meyer, "Linear networks as Mobius transformations, and their invariance properties," *Proc. IEEE*, vol. 59, no. 5, pp. 802–803, May 1971.
- [17] H. Statz, E. A. Guillemin, and R. A. Pucel, "Design considerations of junction transistors at high frequencies," *Proc. IRE*, vol. 42, no. 11, pp. 1620–1628, Nov. 1954.
- [18] R. L. Pritchard, "High frequency power gain of junction transistors," *Proc. IRE*, vol. 43, no. 9, pp. 1075–1085, Sept. 1955.
- [19] R. L. Wallace, Jr. and W. J. Pietenpol, "Some circuit properties and applications of n-p-n transistors," *Proc. IRE*, vol. 39, no. 7, pp. 753–767, July 1951.
- [20] H. Rothe and J. Schubert, "The gain and the admittance matrix of neutralized amplifier stages," *Proc. IEEE*, vol. 54, no. 8, pp. 1046–1055, Aug. 1966.
- [21] J. M. Garg and H. J. Carlin, "Network theory of semiconductor Hall-plane circuits," *IEEE Trans. Circuit Theory*, vol. CT-12, no. 1, pp. 59–73, Mar. 1965.
- [22] H. J. Carlin and J. Rosinski, "Equivalent circuit and loss invariant for helicon mode semiconductor devices," *IEEE Trans. Circuit Theory*, vol. CT-16, no. 3, pp. 365–373, Aug. 1969.
- [23] R. Zuleeg and V. W. Vodicka, "Microwave operation of drift transistors in transit-time mode," *IRE Trans. Circuit Theory*, vol. CT-8, no. 4, pp. 426–433, Dec. 1961.
- [24] M. B. Das and P. Schmidt, "High frequency limitations of abrupt-junction FET's," *IEEE Trans. Electron Devices*, vol. ED-20, no. 9, pp. 779–792, Sept. 1973.
- [25] J. R. Burns, "High-frequency characteristics of the insulated-gate field-effect transistors," *RCA Rev.*, vol. 28, no. 3, pp. 385–418, Sept. 1967.
- [26] T. Mimura *et al.*, "GaAs microwave MOSFET's," *IEEE Trans. Electron Devices*, vol. ED-25, no. 6, pp. 573–579, June 1978.
- [27] W. Baechtold and P. Wolf, "An improved microwave silicon MES-FET," *Solid-State Electron.*, vol. 14, no. 9, pp. 783–790, Sept. 1971.
- [28] N. G. Bechtel, W. W. Hooper, and P. L. However, "Design and performance of the GaAs FET," *IEEE J. Solid-State Circuits*, vol. SC-5, no. 6, pp. 319–323, December 1970.
- [29] H. O. Vickers, "Note on unilateral power gain as applied to submicrometre transistors," *Electron. Lett.*, vol. 24, no. 24, pp. 1503–1505, 24 Nov. 1988.
- [30] S. Prasad, W. Lee, and C. G. Fonstad, "Unilateral gain of heterojunction bipolar transistors at microwave frequencies," *IEEE Trans. Electron Devices*, vol. 35, no. 12, pp. 2288–2294, Dec. 1988; Comments: vol. 36, no. 9, pp. 1861–1862, Sept. 1989.
- [31] J. M. Rollet, "The measurement of transistor unilateral gain," *IEEE Trans. Circuit Theory*, vol. CT-12, no. 1, pp. 91–97, Mar. 1965; also J. Lange, "A much improved apparatus for measuring the unilateral gain of transistors at GHz frequencies," *IEEE Trans. Circuit Theory*, vol. CT-13, no. 4, pp. 461–463, Dec. 1966.
- [32] M. B. Das, "Millimeter-wave performance of ultrasubmicrometer-gate field-effect transistors: a comparison of MODFET, MESFET, and PB7 structures," *IEEE Trans. Electron Devices*, vol. ED-34, no. 7, pp. 1429–1440, July 1987.
- [33] H. F. Cooke, "Microwave transistors: Theory and design," *Proc. IEEE*, vol. 59, no. 8, pp. 1163–1181, Aug. 1971.
- [34] P. R. Johannessen, W. H. Ku, and J. Andersen, "Theory of nonlinear reactance amplifiers," *IEEE Trans. Magn.*, vol. MAG-3, no. 3, pp. 376–380, Sept. 1967.

- [35] P. R. Drouilhet, "Predictions based on the maximum oscillator frequency of a transistor," *IRE Trans. Circuit Theory*, vol. CT-2, no. 2, pp. 178-183, June 1955.
- [36] A. P. Laser and D. L. Pulfrey, "Reconciliation of methods for estimating f_{\max} for microwave heterojunction transistors," *IEEE Trans. Electron Devices*, vol. 38, no. 8, pp. 1685-1692, Aug. 1991.
- [37] M. B. Steer and R. J. Trew, "High-frequency limits of millimeter-wave transistors," *IEEE Electron Device Lett.*, vol. EDL-7, no. 11, pp. 640-642, November 1986.
- [38] M. H. White and M. O. Thurston, "Characterization of microwave transistors," *Solid-State Electron.*, vol. 13, no. 5, pp. 523-542, May 1970.
- [39] P. Wolf, "Microwave properties of Schottky-barrier field effect transistors," *IBM J. Res. Develop.*, vol. 24, no. 1, pp. 125-141, Mar. 1970.
- [40] R. Spence, *Linear Active Networks*. London: Wiley, 1970, p. 215; also M. B. Steer and R. J. Trew, "Comparison of the gain and frequency performance of state-of-the-art MESFET, MODFET, and PBT millimeter-wave transistors," in *Proc. 1987 IEEE Int. Symp. Circuits and Syst.*, vol. 1, May 1987, pp. 19-22.
- [41] C. L. Searle et al., *Elementary Circuit Properties of Transistors*. New York: Wiley, 1964, p. 105.
- [42] G. W. Taylor and J. G. Simmons, "Figure of merit for integrated bipolar transistors," *Solid-State Electron.*, vol. 29, no. 9, pp. 941-946, Sept. 1986.
- [43] L. A. Glasser, "Frequency limitations in circuits composed of linear devices," *IEEE Trans. Circuits Syst.*, vol. 35, no. 10, pp. 1299-1307, Oct. 1988.
- [44] T. E. Rozzi and J. H. C. van Heuven, "Quasi-power algebraic invariants of linear networks," *IEEE Trans. Circuits Syst.*, vol. CAS-21, no. 6, pp. 722-728, Nov. 1974.
- [45] J. H. C. van Heuven and T. E. Rozzi, "The invariance properties of a multivalued n-port in a linear embedding," *IEEE Trans. Circuit Theory*, vol. CT-19, no. 2, pp. 176-183, Mar. 1972.
- [46] —, "Two applications of algebraic invariants to linear transmission networks," *IEEE Trans. Circuits Syst.*, vol. CAS-23, no. 11, pp. 641-647, Nov. 1976.
- [47] K. Kurokawa and W. O. Schlosser, "Quality factor of switching diodes for digital modulation," *Proc. IEEE*, vol. 58, no. 1, pp. 180-181, Jan. 1970.
- [48] S. Kawakami, "Figure of merit associated with a variable-parameter one-port for RF switching and modulation," *IEEE Trans. Circuit Theory*, vol. CT-12, no. 3, pp. 321-328, Sept. 1985.



Madhu S. Gupta (S'68-M'72-SM'78-F'89) received the Ph.D. degree in electrical engineering from the University of Michigan, Ann Arbor, in 1972.

He served as a faculty member at Massachusetts Institute of Technology, Cambridge (1973-79), and at the University of Illinois, Chicago (1979-87), and as a Visiting Professor at University of California, Santa Barbara (1985-86). Since 1987, he has been with Hughes Aircraft Company, working at Hughes Research Laboratories, Malibu, Calif., and at Microelectronic Circuits Division, Torrance, CA, where he is a Senior Member of the Technical Staff, and is engaged in the modeling, design and characterization of GaAs devices and integrated circuits, the evaluation of in-process wafers, and the development of low noise technology.

Dr. Gupta is a member of Eta Kappa Nu, Sigma Xi, Phi Kappa Phi, and the American Society for Engineering Education, and is a Professional Engineer. He has served as the Chairman of the Boston and Chicago chapters of the IEEE Microwave Theory and Techniques Society, and of an IEEE Standards Committee. He has also served on the Speakers' Bureau of the IEEE MTT Society, and is a member of the Editorial Board of *IEEE TRANSACTIONS ON MICROWAVE THEORY AND TECHNIQUES*. Dr. Gupta has published nearly 100 writings, including journal articles, conference and invited papers, patents, book chapters, and reviews. He is the editor of *Electrical Noise: Fundamentals and Sources* (IEEE Press, 1977), *Teaching Engineering: A Beginner's Guide* (IEEE Press, 1987), and *Noise in Circuits and Systems* (IEEE Press, 1988).