

*EE 42/100*

*Lecture 4: Resistive Networks and Nodal Analysis*

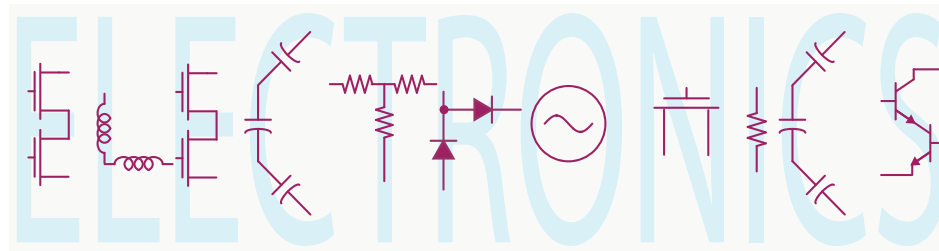

Rev B 1/25/2012 (9:49PM)

Prof. Ali M. Niknejad

University of California, Berkeley

Copyright © 2012 by Ali M. Niknejad

## Parallel Notation

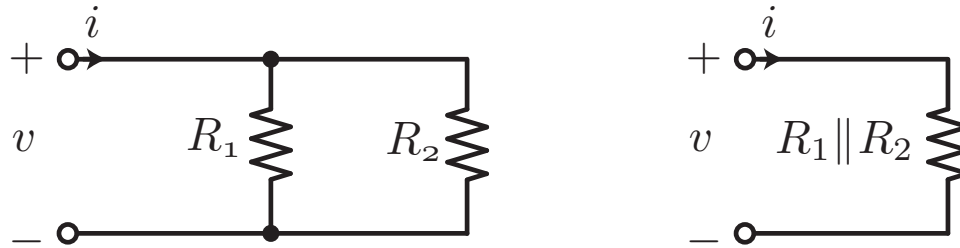

- Last lecture we learned that two resistors in parallel can be combined as follows

$$R_{eq} = \frac{R_1 R_2}{R_1 + R_2}$$

- It's very common notation to write  $R_{eq} = R_1 || R_2$ , in other words we define an operator '||' that takes two inputs outputs

$$x || y = \frac{xy}{x + y}$$

- Note that if  $x \gg y$ , then

$$x || y = \frac{xy}{x + y} = \frac{y}{1 + \frac{y}{x}} \approx y$$

# Current Source

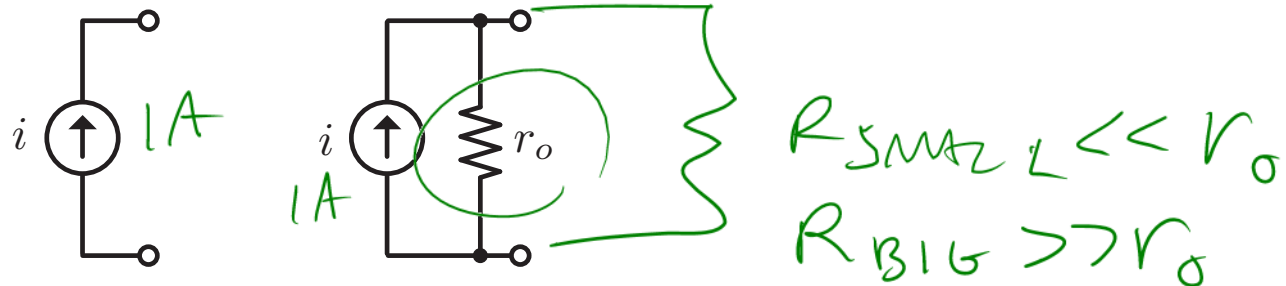

- A current source is the dual of a voltage source. It supplies a constant current regardless of the external voltage applied to its terminals. This property means that it has infinite compliance, or infinite output resistance. In contrast, a voltage source has a constant voltage regardless of the current drawn. It has zero output resistance.
- Unlike a voltage source, there are no everyday examples (such as batteries) that can be used to illustrate the principal of a current source. Transistors in the “forward active” region do behave like current sources, but for that you’ll have to wait until later.
- Any real current source has finite output resistance, but it’s typically very large. Contrast this with a real voltage source.

## Your Taste for Opens and Shorts

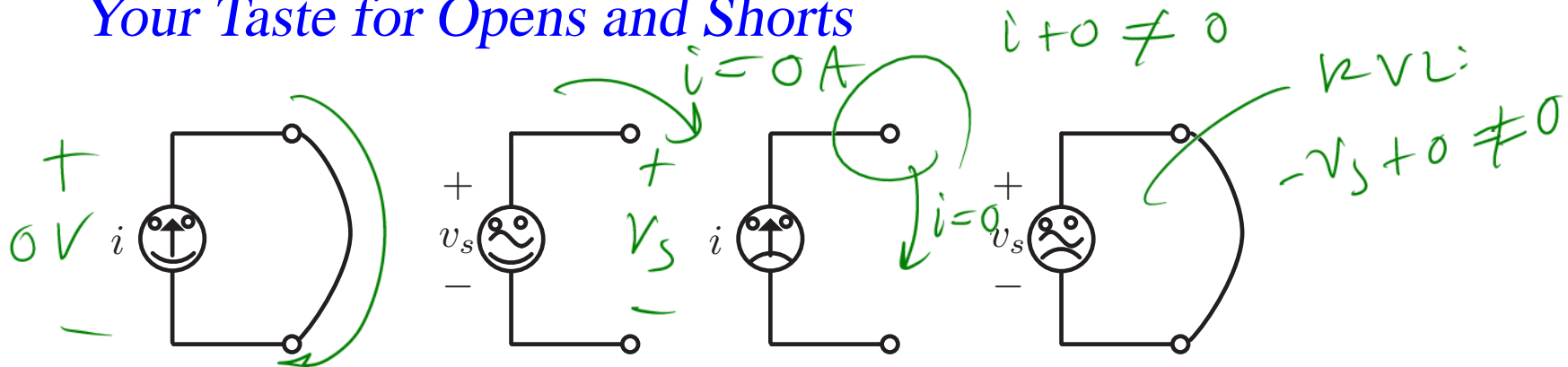

- Recall that voltage sources detest short circuits, because that violates KCL. Also, two voltage sources cannot be put in parallel. Voltage sources do like open circuits, because they don't draw any power.
- The current source as the dual relationship. It cannot drive an open circuit, because that violates KCL. Likewise, two current sources cannot be put in series.
- Current sources love short circuits, and they happily deliver all of their current to a short circuit. This results in no power draw (why?).

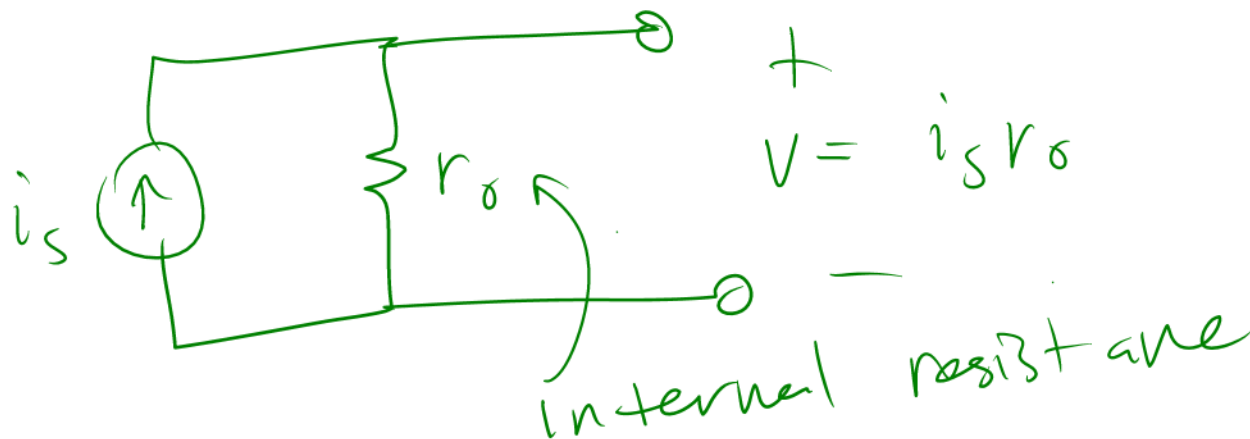

# Battery Charger

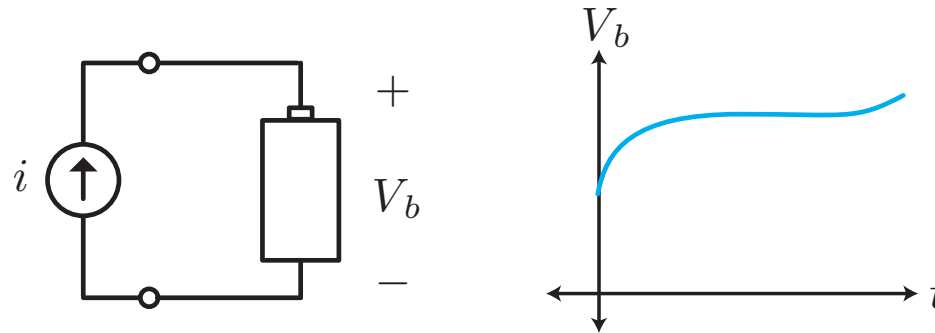

- A simple battery charger can be made with a current source. A real battery has a discharge curve, in other words as you draw current from the battery, the output voltage drops. A current source can be used to charge the battery, and it will deliver current regardless of the battery voltage. Of course, we need provisions to turn off the current source when the battery is full.
- In the old days, a timer was used to control how long the current was on. In more modern units, the charger monitors the battery voltage and detects when the battery is full.

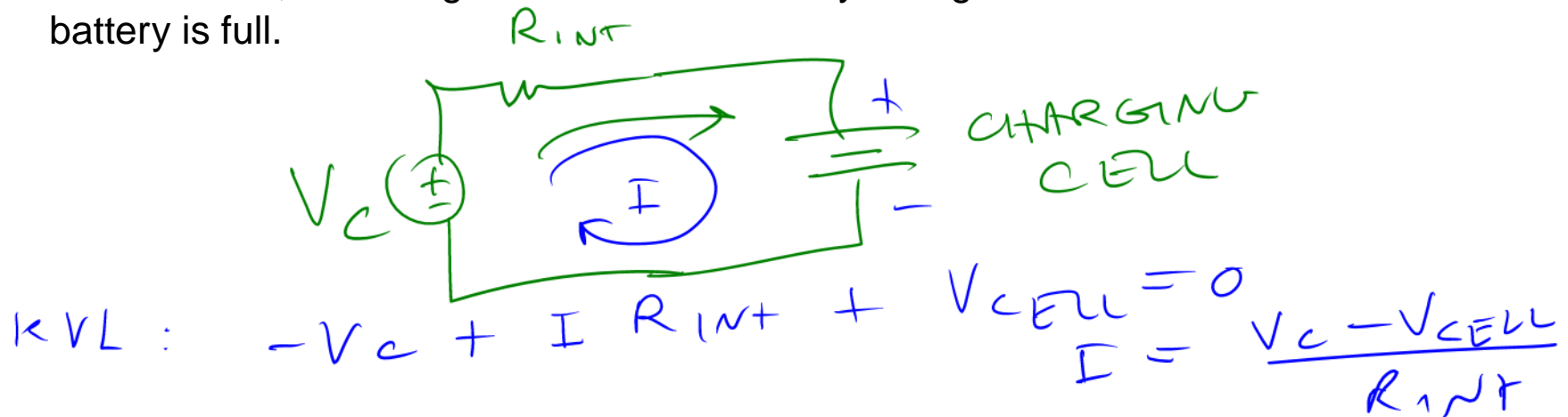

WHAT HAPPENS WHEN YOU TURN  
OFF A SOURCE?



OFF  $\Rightarrow V = 0V \Rightarrow$  SHORT CIRCUIT

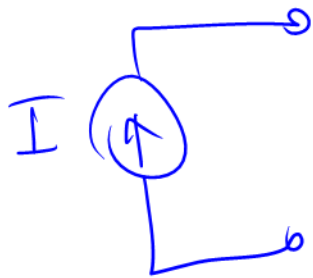
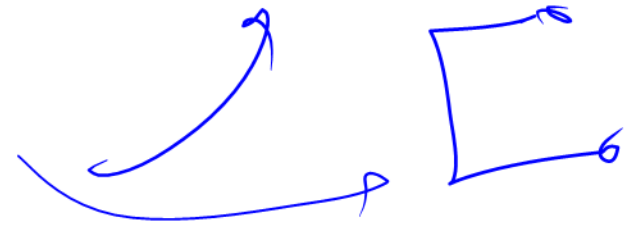
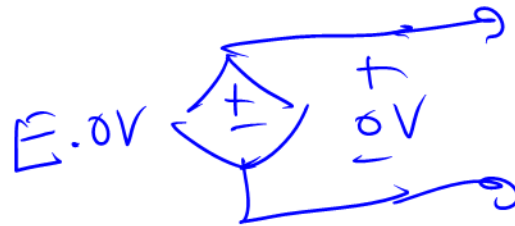

OFF  $\Rightarrow I = 0A \Rightarrow$  OPEN CIRCUIT



# Dependent Sources *vccs*

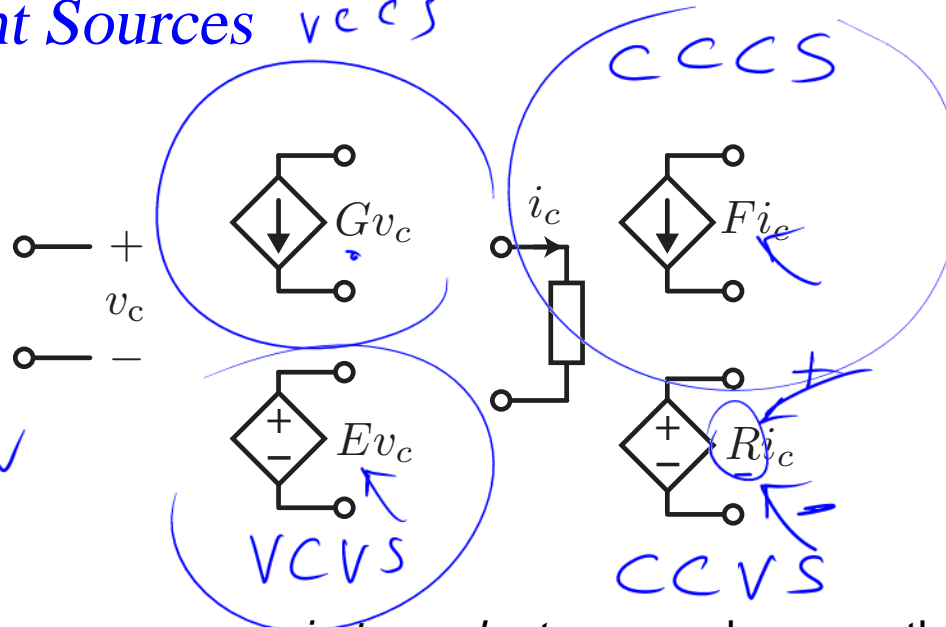
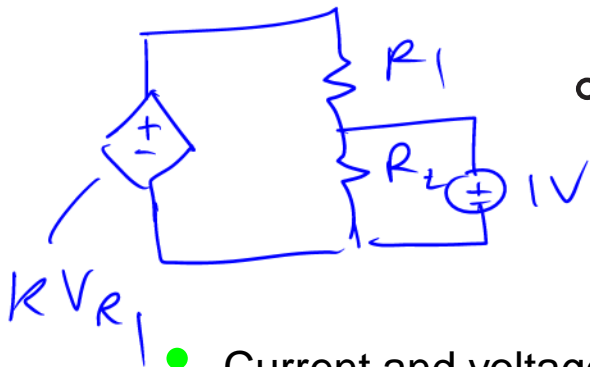

- Current and voltage sources are *independent* sources because their output is independent of any other currents or voltages in the circuit. In contrast, dependent sources depend directly on the the voltage or current in other parts of the circuit.
- Four flavors are possible: Voltage Controlled Voltage Source (VCVS), Voltage Controlled Current Source (VCCS), Current Controlled Voltage Source (CCVS), and Current Controlled Current Source (CCCS).
- A VCCS is an ideal voltage amplifier or attenuator (gain < 1), while a CCCS is an ideal current amplifier. Sometimes the signal of interest is a current while the desired output is a voltage. A CCVS is an ideal trans-resistance amplifier, because the gain has units of resistance. A trans-conductance amplifier does the inverse.

# Voltage Divider

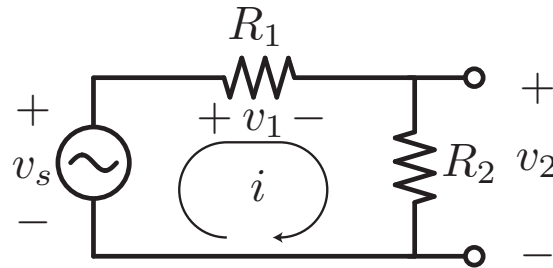

- A voltage divider is an extremely useful circuit since it allows us to derive any fraction of the source voltage at the output.
- Notice that the current in the circuit is given by

$$i = \frac{v_s}{R_1 + R_2}$$

- Suppose the output voltage  $v_2$  is connected across the terminals of  $R_2$ . Let's calculate the output voltage  $v_2$  in terms of the source voltage  $v_s$

$$v_2 = iR_2 = \frac{R_2}{R_1 + R_2}v_s = \alpha v_s$$

- Note that the factor  $\alpha \leq 1$ . By changing either  $R_1$ ,  $R_2$ , or both, we can vary the attenuation of the circuit. Between  $R_1$  and  $R_2$ , the largest resistor wins (gets the majority of the voltage drop).



# Rheostats and Potentiometers

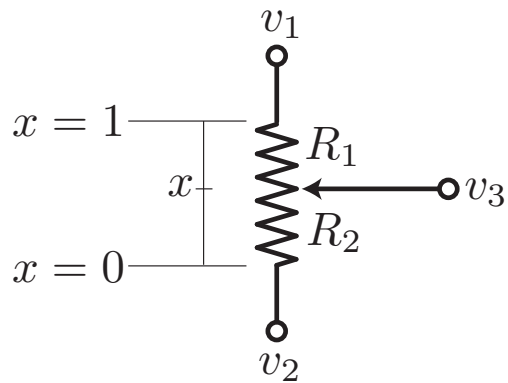

Source: Wikipedia

- A variable resistor is called a rheostat. A related element has three terminals and it's called a potentiometer. It's typically constructed so that it presents a fixed resistance  $R$  across two of its terminals. The third terminal is connected to a point between the two other terminals in such a way that the resistance  $R_2$  varies linearly (or perhaps logarithmically depending on the application).

$$R_{TOTAL} : R_{MIN} - R_{MAX} = R_{TOTAL}$$

LINEAR, LOG POT

## Potentiometer Divider

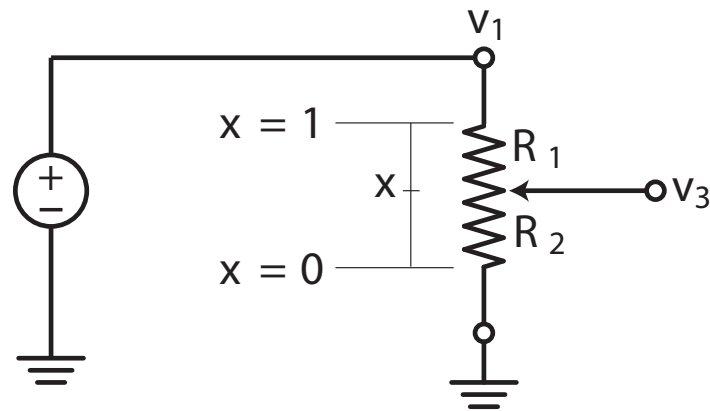

- For the circuit shown, since the total resistance is fixed, we can write

$$v_3 = \frac{R_2}{R_1 + R_2} v_s = \frac{x(R_1 + R_2)}{R_1 + R_2} = x v_s.$$

where  $x \leq 1$ .

# Current Dividers

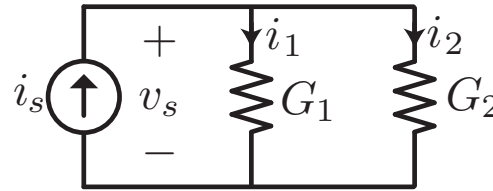

PARALLEL

- Suppose two conductors are placed in parallel. The current  $i_s$  then splits into the two conductors. The ratio of the current into say  $G_1$  can be calculated as follows

$$i_1 = G_1 v_s$$

Ohm's Law

where  $v_s$  is the voltage across the terminals of the conductors (equal by KVL). This is computed from the total equivalent conductance

$$v_s = (G_1 + G_2)^{-1} i_s$$



- Substituting the above relation, we have that the current into  $i_1$  is given by

$$i_1 = \frac{G_1}{G_1 + G_2} i_s = \frac{R_2}{R_1 + R_2} i_s = \beta i_s$$

Handwritten notes:  $\frac{1/R_1 \times R_1 R_2}{(1/R_1 + 1/R_2) R_1 R_2}$

- As before,  $\beta \leq 1$  and the largest conductance (smallest resistance) "wins" (get the majority of the current).

# Shorts and Opens Again

GENERALIZATION

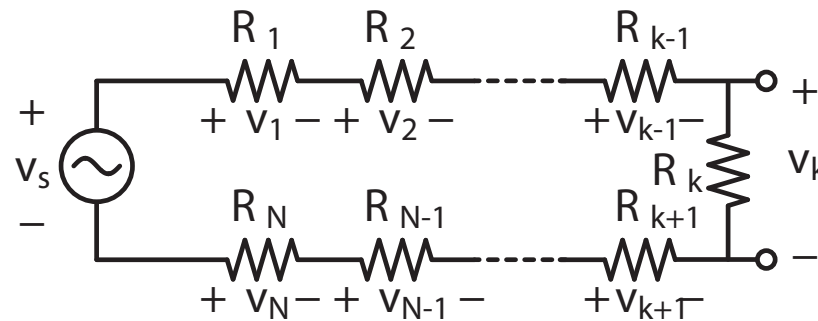
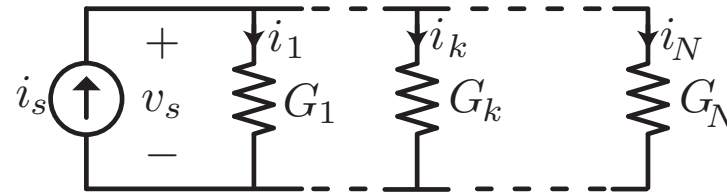

- The equations for voltage divider and current divider are easy to generalize to  $N$  series or parallel resistors

$$v_k = \frac{R_k}{\sum R_j} v_s$$

$$i_k = \frac{G_k}{\sum G_j} i_s$$

# Winners and Losers

- In a current divider, a short circuit always wins!

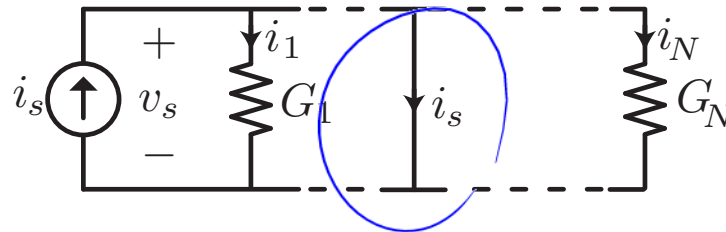

- In a voltage divider, an open circuit always wins.

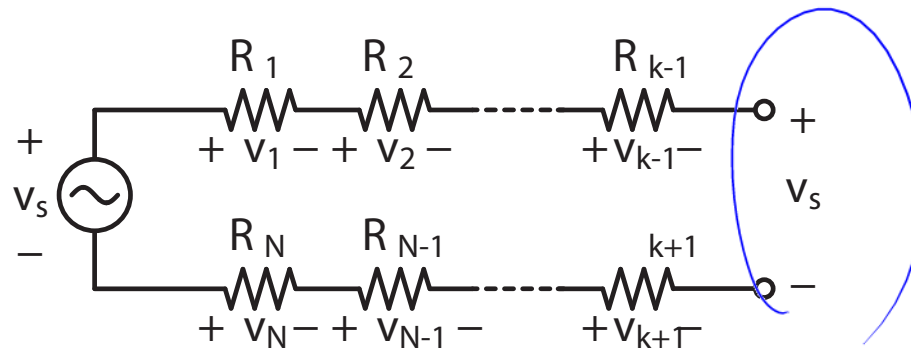

## (Bad) Application: Light Dimmer

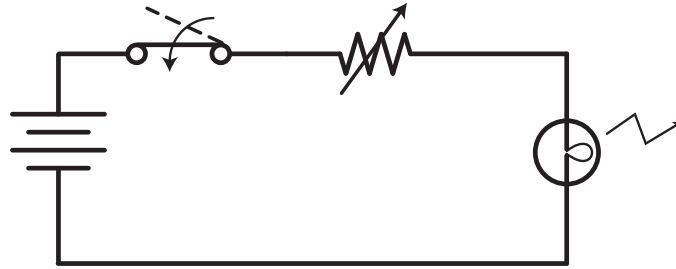

- Suppose we wish to build a light dimmer using a rheostat. By adding a resistor in series, we can control the voltage drop across the lamp, which is modeled as an equivalent resistor. For  $R = 0\Omega$ , the bulb radiates at full intensity. For  $R = \infty\Omega$ , the light shuts off.
- Example: Say a 10W light bulb works off a 12V battery. It has an equivalent DC resistance of

$$\frac{V^2}{R_{eq}} = 10 \text{ W} \rightarrow R_{eq} = \frac{V^2}{10 \text{ W}} = 14.4\Omega$$

- The lamp draws  $I = 10 \text{ W}/12 \text{ V} = 0.83 \text{ A}$  at full intensity. To go to 10% light level, we should reduce the current by a factor of 10. In other words, the equivalent series combination of the rheostat and lamp should present

$$R_T = \frac{12V}{I_{LL}} = \frac{12V}{\frac{10}{1200}} = 1440\Omega$$

- Which means the rheostat should have a resistance of  $R_{max} = 1440\Omega - 14.4\Omega$ .
- Why is this a bad idea?

## Dimmer with Potentiometer?

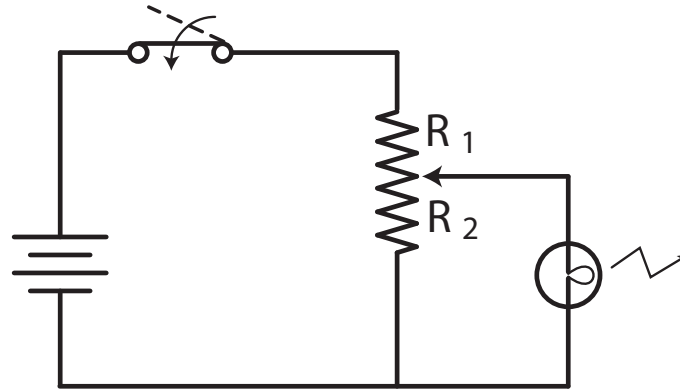

- You may have wondered why we didn't use a potentiometer to control the light level. The reason is that the equation we derived for the potentiometer neglected the *loading* effect of anything connected to the third terminal.
- You can now see that the correct voltage divider equation is given by

$$V_{bulb} = \frac{R_{bulb} || R_2}{R_1 + R_{bulb} || R_2}$$

- This is not as straightforward as we thought. If  $R_2 \ll R_{bulb}$ , then the desired equation would follow but then a lot of unnecessary power would be wasted in  $R_1$  and  $R_2$ . Why?