

EE 42/100

Lecture 3: Circuit Elements, Resistive Circuits

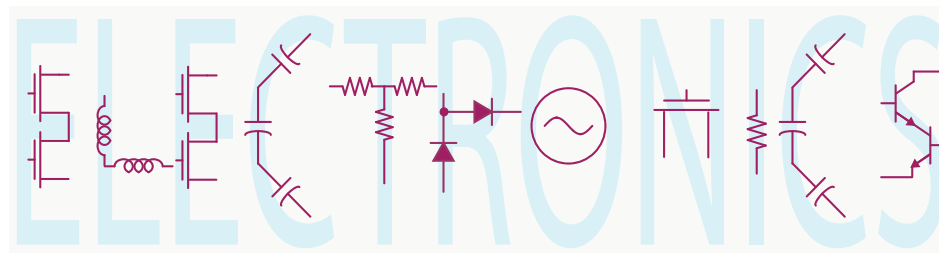

Rev D 1/22/2012 (4:19PM)

Prof. Ali M. Niknejad

University of California, Berkeley

Copyright © 2012 by Ali M. Niknejad

Ideal Conductors

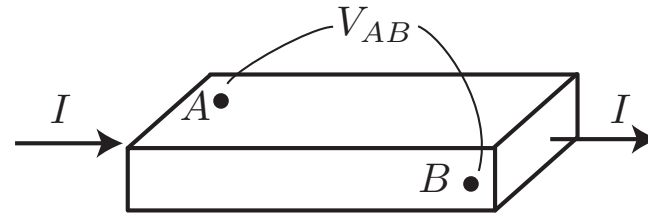

- An ideal conductor is an equipotential body. It can support any current without incurring a potential drop – i.e. it has zero resistance. Between any two points on an ideal conductor, $V_{AB} \equiv 0$.
- Ideal wires, which connect components in an electrical schematic, are made from ideal conductors.
- An ideal ground would use an ideal conductor to serve as a constant reference potential for the circuit. In a PCB (printed circuit board), a “ground plane” is commonly used to provide a low resistance path to the power source. It is also convenient for wiring, since any component can “via” down to the ground, thus eliminating all wire traces to ground.

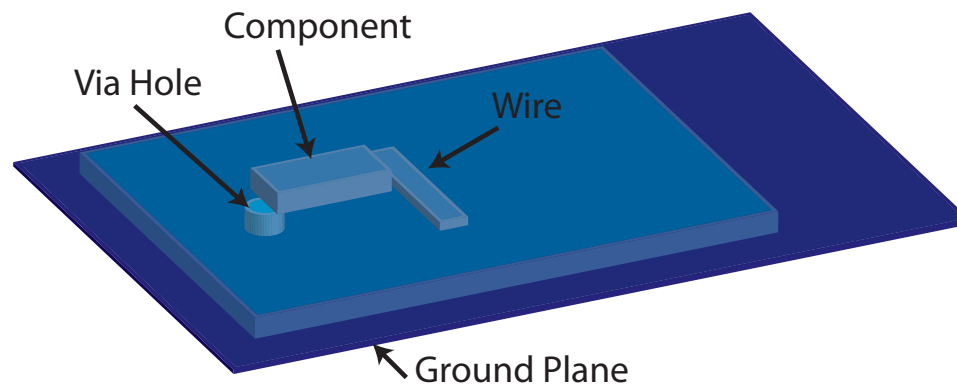

Real Conductors

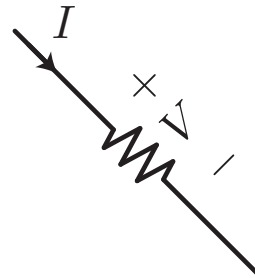

- Real conductors have “resistance”, which impedes the flow of current by producing a voltage drop across the path of the current. The higher the current, the higher the voltage drop.
- Remarkably, the voltage drop is exactly proportional to the current. This is a statement of Ohm’s Law

$$V = I \cdot R$$

- The proportionality constant is known as the resistance of the conductor. The unit of R is Voltage/Ampere, or more commonly “Ohms” (Ω).
- Such a conductor is known as a resistor. The value of resistance can be altered by using different materials in the construction of the component. The schematic representation for a resistor is shown above, which hints that the current is impeded.

Is Ohm's Law Strange?

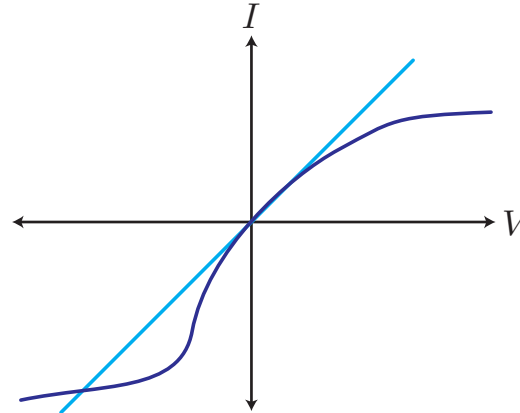

- It's also remarkable that this linear relation holds true over a wide range of voltages. In general, one might expect a power series relation to model the current voltage relationship

$$V = f(I) = R_1 I + R_2 I^2 + \dots$$

- But for all practical purposes, R_1 is the only term that matters.
- The voltage drop across a resistor is V . Note that the V represents how much energy is lost by a unit of charge as it moves through the resistor element.
- The current I we have learned is proportional to the velocity of charge carriers (such as electrons). We would therefore expect a quadratic relation, not linear, between the current and voltage (Kinetic energy).

Real Resistance

- The answer to this riddle lies in the fact that carriers do not move unimpeded through a conductor (in vacuum they would in fact have a quadratic dependence) but rather the motion is mostly random motion.
- On average the charge carriers move only a short distance before colliding with atoms (impurities) in the crystal. After the collision all “memory” of the previous path of motion is lost and the energy of the carrier is converted into heat (vibrations in the crystal). The gain in momentum is proportional to the voltage.

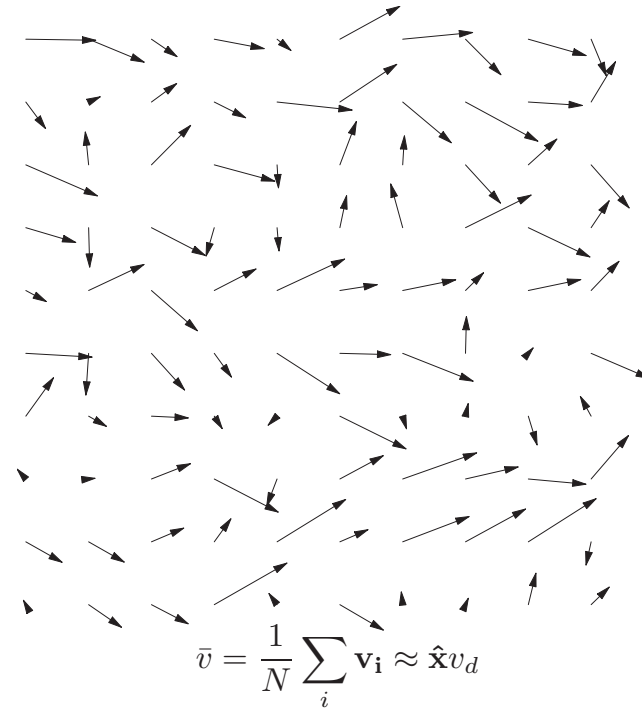

Calculating Resistance

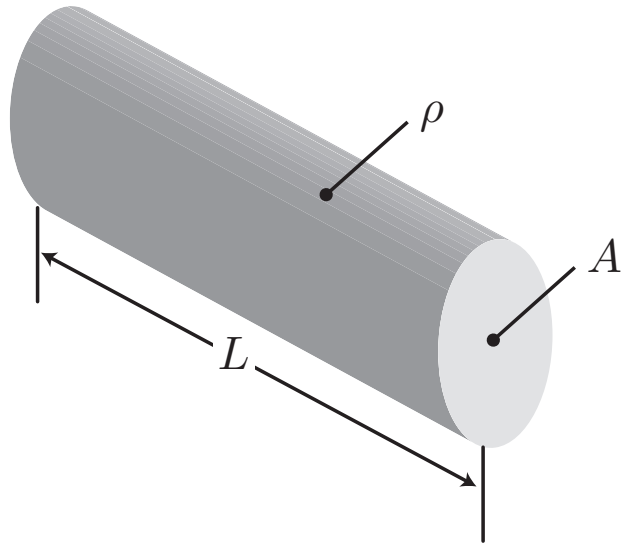

Material	Resistivity $\Omega - m$
Copper (Cu)	1.72×10^{-8}
Gold (Au)	2.27×10^{-8}
Silicon (Si)	$10^{-5} \sim 1$
Quartz (SiO_2)	$> 10^{21}$
Teflon	10^{19}

- For a wire of uniform cross area, the resistance is calculated as follows

$$R = \frac{\rho L}{A}$$

- It's proportional to the length L of the wire, inversely proportional to the cross sectional area A , and proportional to the material resistivity ρ .
- The resistivity of some common conductors and insulators is shown in the table above. Note the enormous range in resistivity.

Conductance and Conductivity

- It's sometimes convenient to think in terms of conductivity rather than resistivity. We re-cast Ohm's Law as

$$I = G \cdot V$$

- where G is the conductance of a resistor. Note that this is simply the inverse of resistance, $G = 1/R$. The units of G are inverse Ohms (Ω^{-1}), also called Siemens (S).
- Similarly, the conductance of a material can be calculated from the equation

$$G = \frac{\sigma A}{L}$$

- σ is the material conductivity, which is the inverse of the resistivity $\sigma = 1/\rho$.

Power Loss in Resistors

- From the equation for the power loss in a component, we have

$$P = V \cdot I = (R \cdot I) \cdot I = I^2 R$$

- Or in terms of conductance

$$P = V \cdot I = V \cdot (G \cdot V) = V^2 G$$

- This power is lost to heat or “Joule Heating”. In fact, most electric ovens use resistors to heat up the oven.
- Nichrome (nickel-chromium alloy) is often used as the heating element. It has a high melting point of 1400°C and a high resistivity and resistance to oxidation at high temperature. It is widely used in ovens, hair dryers, and toasters.

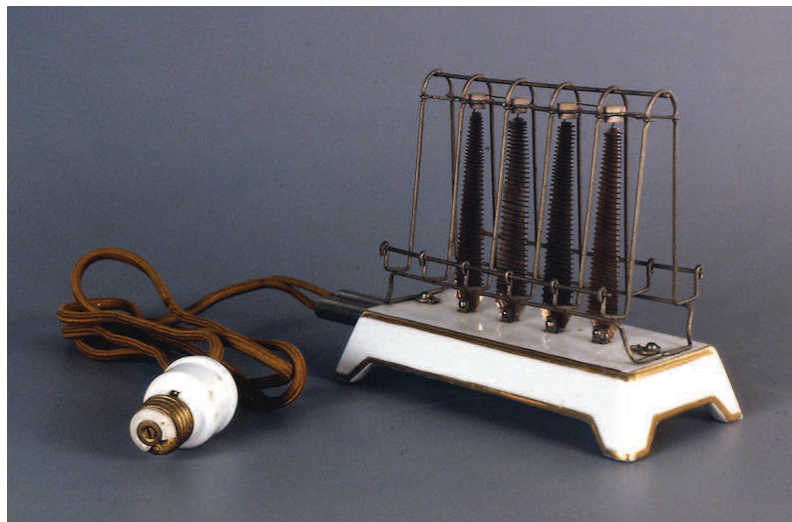

Resistors versus Resistance

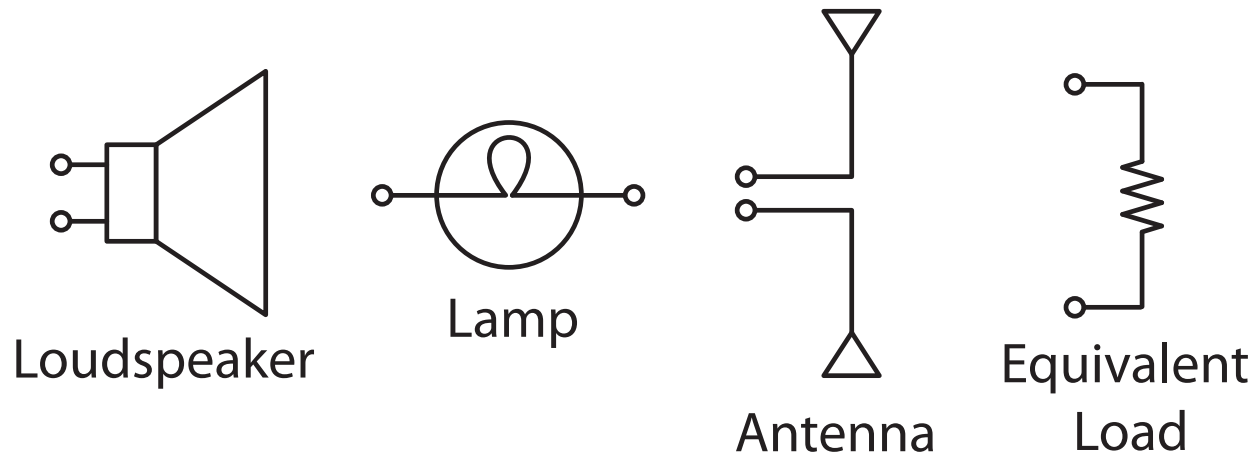

- It's important to realize that we often use a resistor in a schematic to model the equivalent resistance of many components, which may not be resistors at all.
- Take for example a loudspeaker, which primarily converts electrical energy into sound (pressure waves). Such a component does not ideally dissipate any power as heat, and yet the power conversion into sound can be represented by an equivalent resistance ($R_{\text{speaker}} = 8\Omega$).
- Other examples include a light bulb (converts electricity into heat and light), an antenna (which converts electricity into electromagnetic radiation), or an entire house which contains hundreds of individual devices dissipating energy.

Example: Why Power is Delivered with High Voltages



- For economic and environmental reasons, power is usually generated remotely (wind farms, electric dam, nuclear power plants, etc). Many hundreds of miles of wires are required to carry the energy to the factories and homes.
- Since wires have resistance, the resistive loss is energy which is completely lost without doing any useful work (except warming up the planet).
- Since the line voltage is fixed (say 120V into the home), the power draw is represented by a varying I_{load} . The equivalent circuit (next page) shows that the "load" can be represented by R_{load} and the power loss is proportional to $I_{load}^2 R_{wire}$.

100-km Energy Loss

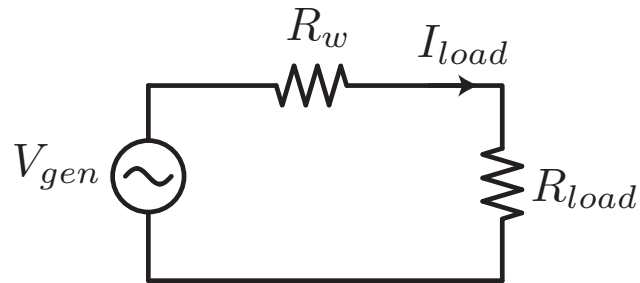

- Say a house is dissipating $P = 1.2\text{kW}$ of power. If the house operated from a 120V DC source, then that's a current draw of (note we're ignoring the fact that most power delivered is AC rather than DC, but as we'll learn later, that's a simple correction factor)

$$I_{load} = P/V = 1\text{kW}/120\text{V} = 10\text{A}$$

- Assume a copper wire of 5mm radius and 100km long

$$R_w = \rho \frac{L}{A} = \rho \frac{L}{\pi r^2} = 1.72 \times 10^{-8} \times \frac{100 \times 10^3}{\pi (5 \cdot 10^{-3})^2} = 22\Omega$$

- The power lost to heat is

$$P_{loss} = I_{load}^2 R_w = 2.2\text{kW}$$

- That's more than the power delivered! The efficiency of this system is very low.

High-Voltage Lines

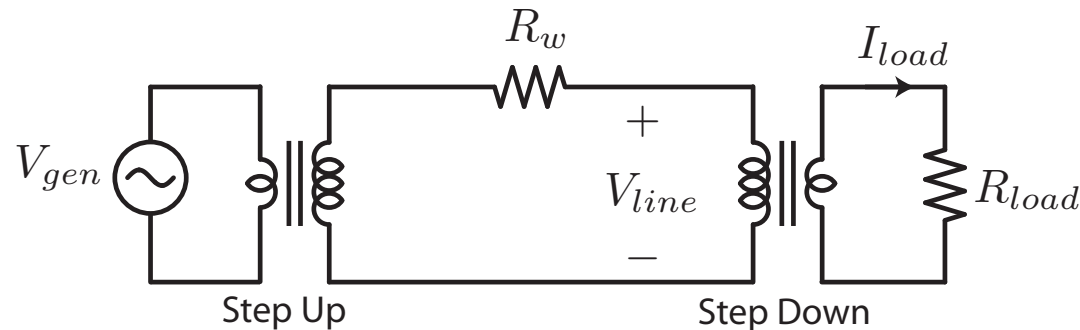

- The key is to transform the voltage to a much higher value to minimize the current. One key reason why we use AC power is so that we can use transformers to easily boost the voltage on the lines, and then to drop the voltage to more reasonable values as we get near residential areas (for safety).
- In the above example, the voltage is increased to 100kV, and so the equivalent current needed to deliver 1.2kW is decreased substantially

$$I_{load,line} = P/V_{line} = 0.012A$$

- And so that the energy lost to heat is minimized

$$P_{loss} = I_{load,line}^2 R_w = 3mW$$

Application: Strain Gauge

- A strain gauge uses the change in resistance induced by the change in the dimensions of materials $L = L_0 + \Delta L$ under strain, $R = \rho \frac{L}{A}$. Define

$$G \equiv \frac{\frac{\Delta R}{R_0}}{\epsilon}$$

where ϵ is the strain and G is the gauge factor.

- For example, suppose $R_0 = 500\Omega$, $G = 3$ and a 1% strain is applied. Then $\Delta R = R_0 \cdot G \cdot \epsilon = 15\Omega$. Precise changes in resistance can be measured with a Wheatstone Bridge.

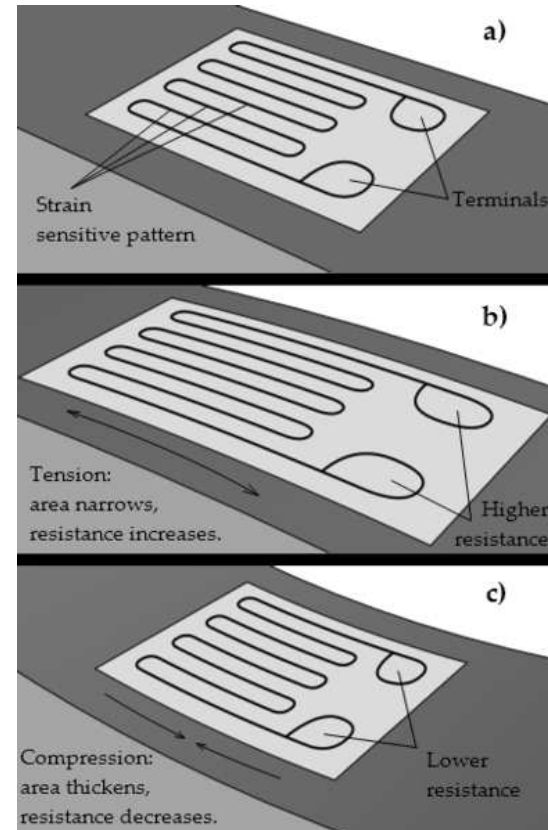

Source: Wikipedia

Series Resistors

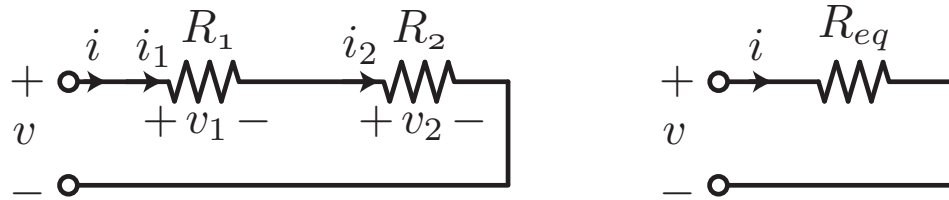

- Consider two resistors in series. The voltage across the two resistors is the sum of the voltage across each individual resistor (KVL)

$$v = v_1 + v_2 = i_1 R_1 + i_2 R_2$$

- From KCL, we know that the currents through the resistors is equal, and so we can write $i = i_1 = i_2$

$$v = i(R_1 + R_2) = iR_{eq}$$

- where R_{eq} is an equivalent resistance which describes the behavior of the series connection of the resistors. As you would expect, the net resistance increases when resistors are placed in series.

Resistance of Wires

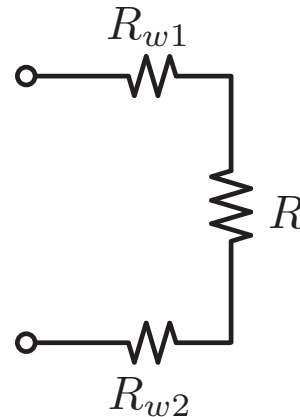

- In any real circuit, the wires are made from conductors that have resistance as shown. To be exact, we should include series resistor as shown above to model the wire resistances R_w .
- For instance, the current into a resistor is given by

$$I = V/R_{eq} = V/(R + R_{w1} + R_{w2})$$

- This is tedious because in practice and unnecessary if we can make the wire resistance much smaller than the component resistances: $R \gg R_w$.

N Resistors in Series

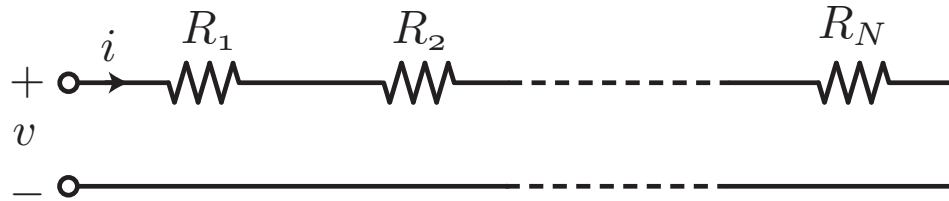

- The concept of series resistors generalizes since we have from KVL and KCL

$$v = v_1 + v_2 + \cdots + v_N = i(R_1 + R_2 + \cdots + R_N)$$

$$R_{eq} = \sum R_k$$

Parallel Resistors

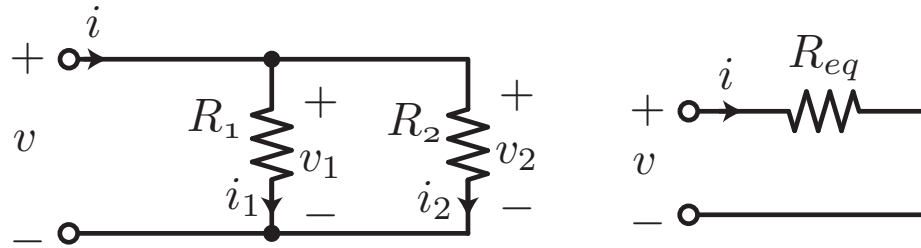

- Shunt resistors are the “dual” of series resistors if we consider the conductance of the circuit. From KVL we know that the voltage across the shunt (parallel) components is equal

$$v_1 = v_2 = v$$

- From KCL we also know that the total current into the network is the sum of the currents of the individual components

$$i = i_1 + i_2$$

or

$$i = G_1 v_1 + G_2 v_2 = (G_1 + G_2)v = G_{eq}v$$

- Conductance of shunt resistors add.

Alternative Expressions for Parallel Resistors

- Another useful expression is directly in terms of resistance

$$\frac{1}{R_{eq}} = \frac{1}{R_1} + \frac{1}{R_2}$$

or

$$R_{eq} = \frac{1}{\frac{1}{R_1} + \frac{1}{R_2}} = \frac{R_1 R_2}{R_1 + R_2}$$

- For N resistors in parallel, the result generalizes

$$G_{eq} = G_1 + G_2 + \cdots + G_N$$

or

$$R_{eq} = \frac{1}{\frac{1}{R_1} + \frac{1}{R_2} + \cdots + \frac{1}{R_N}}$$

Example: "Christmas" Lights

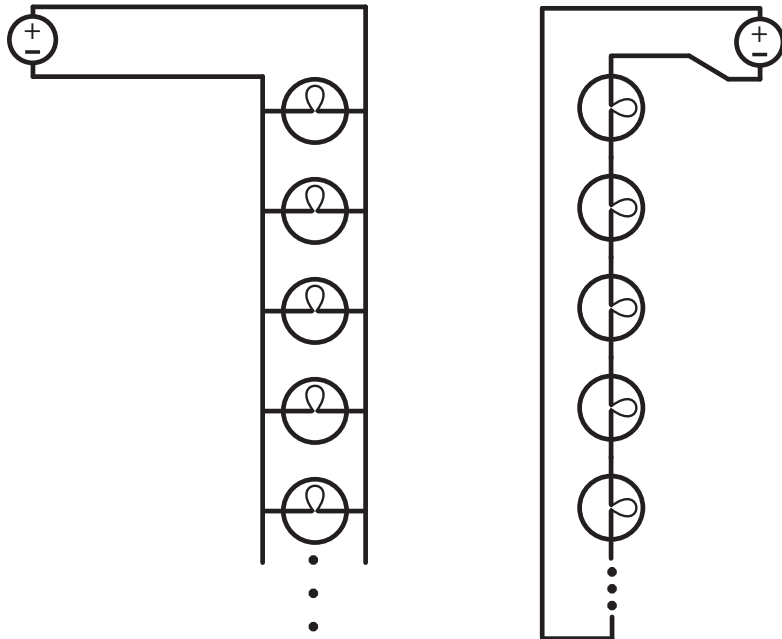

- Let's say we want to light up a string of lights and use the minimum number of wires. We can connect the lights in series or in shunt.
- When placed in series, if a single light fails and goes into an open circuit state (typical failure mode), then all the lights turn off. On the other hand, if one of the lights short circuits, then all the other lights would continue to work (albeit with a slightly higher voltage).
- If the lights are placed in shunt, then if one light fails (open circuit), all the other lights continue to work unabated. If a short circuit occurs (unlikely), though, then all the lights are shorted and turn off.

Internal Resistance of Battery

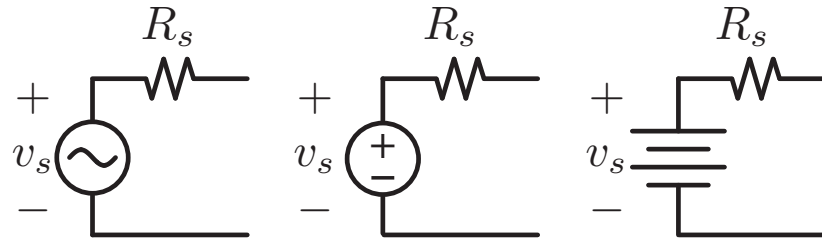

- Every real battery has some internal resistance, which is represented as a series resistor in the schematic above. The output voltage therefore drops if you draw more current from the battery.
- The maximum current available from the battery is also set by this resistance, because even a perfect short circuit across the battery can only draw $i = v_s / R_s$.
- When two batteries are connected in parallel, the current draw from the larger voltage battery to the smaller battery is determined by the sum of their internal resistances.

Example: Microprocessor Power Supply

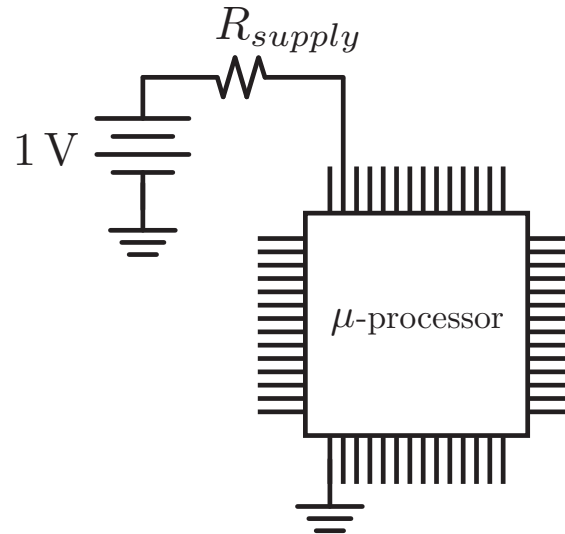

- Consider a high performance microprocessor that operates on a 1V power supply (this is typical for nanoscale CMOS technology). During peak operation, it dissipates 50W. Calculate the supply resistance in order to incur only a 10% efficiency loss.
- Solution: Note that the current draw is huge (due to the low supply voltage):
 $I = P/V = 50\text{W}/1\text{V} = 50\text{ A}$.
- As a load, the microprocessor can be modeled as a resistor of value

$$R_{\mu} = \frac{1\text{V}}{50\text{A}} = .02\Omega$$

Microprocessor (cont)

- The efficiency of the system can be written as

$$\begin{aligned}\eta &= \frac{P_\mu}{P_\mu + P_{loss}} = \frac{I^2 R_\mu}{I^2 R_\mu + I^2 R_{supply}} \\ &= \frac{R_\mu}{R_\mu + R_{supply}} = 90\%\end{aligned}$$

$$R_{supply} \cdot 9 = 0.1 R_\mu \rightarrow R_{supply} = R_\mu / 9 = 0.0022 \Omega$$

- The supply must have an extremely low source resistance. In practice the current is delivered from multiple supplies each “regulated” (so that the fluctuations from the external supply do not cause problems) with a circuit that uses *feedback* to realize very low source resistance.