

EE 42/100

Lecture 2: Charge, Current, Voltage, and Circuits

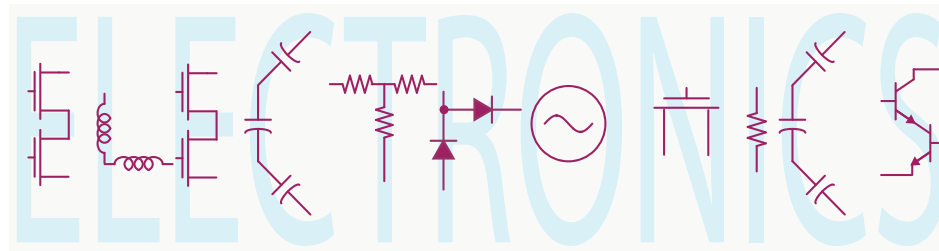

Revised 1/18/2012 (9:04PM)

Prof. Ali M. Niknejad

University of California, Berkeley

Copyright © 2012 by Ali M. Niknejad

Charge and Current

- A conductor is a material where chargers are free to move about. Even in “rest”, the charge carriers are in rapid motion due to the thermal energy. Typical carriers include electrons, ions, and “holes” (in semiconductors).
- Current is charge in motion. When positive charges move in the positive direction, we say the current is positive. If negative charges move in the same direction, we say the current is negative. In other words, the current flowing through a surface is defined as

$$I = \frac{\text{Net charge crossing surface in time } \Delta t}{\Delta t}$$

where Δt is a small time interval. The units of current are $[I] = [C/s] = [A]$, or ampere (after André-Marie Ampère).

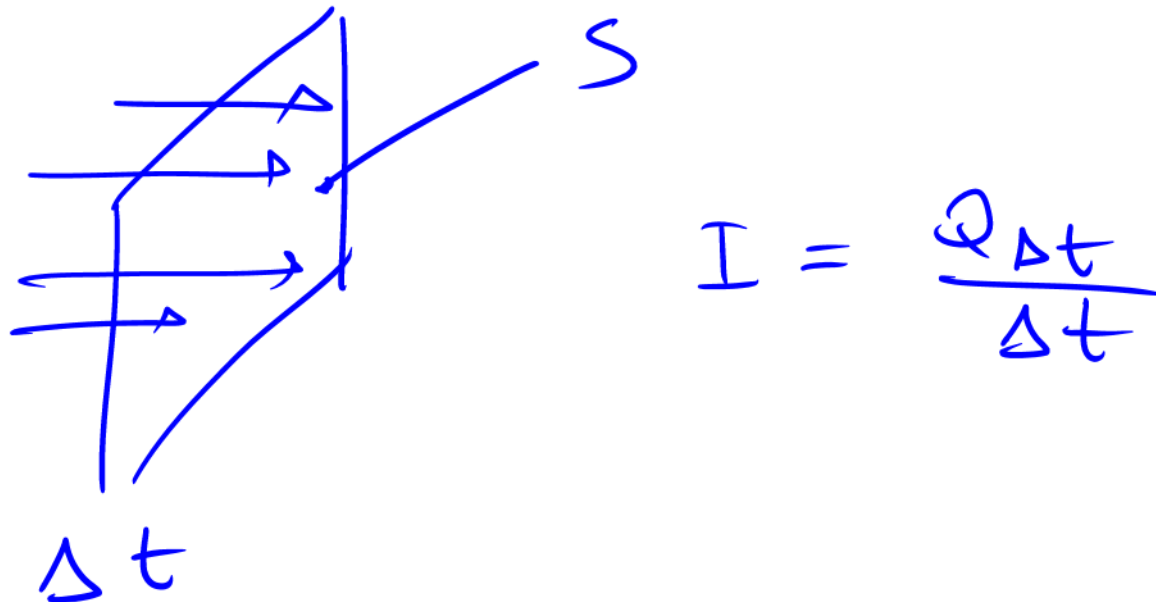

Charge and Current

- When both positive and negative charge are moving, the net charge motion determines the overall current.

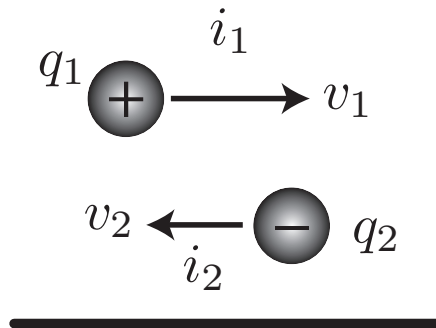

Net current is $i = i_1 + i_2$

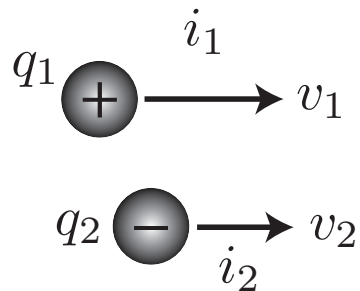

Net current is $i = i_1 - |i_2|$

$$i_2 < 0$$

Counting Charges

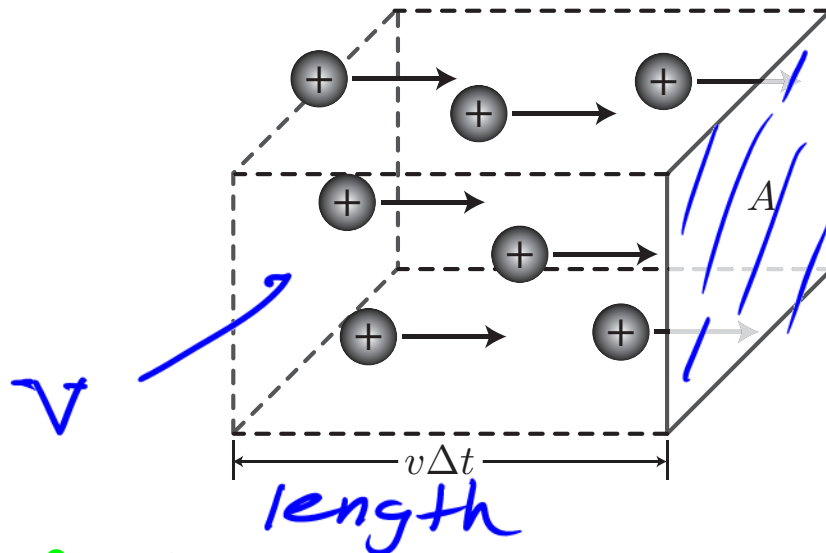

- Suppose that the charge carriers each have a charge of q . Let's count the number of charges (c) crossing a surface in time Δt and multiply by the electrical charge

$$I = \frac{q \cdot c}{\Delta t}$$

charge (pointing to q) and *count* (pointing to c)

- To find c , let's make the simple assumption that all the charges are moving at a speed of v to the right.
- Then the distance traversed by the charges in time Δt is simply $v\Delta t$, or in other words if we move back from the surface this distance, all the charges in the volume formed by the cross-sectional surface A and the distance $v\Delta t$ will cross the surface in time Δt . This means that

$$I = \frac{q \cdot v\Delta t N A}{\Delta t} = q(N A)v$$

where N is the density of electrons per unit volume.

$$I \propto v N A$$

N x VOLUME (with a bracket under VOLUME)
v
A

Motion of Real Charges

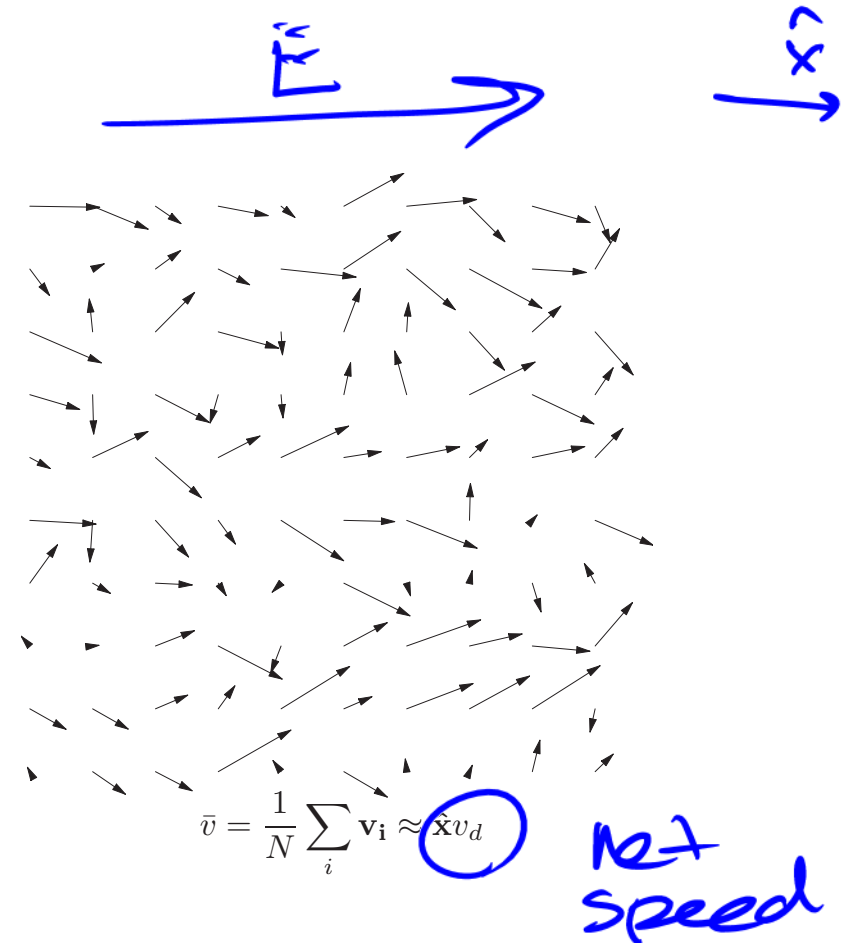
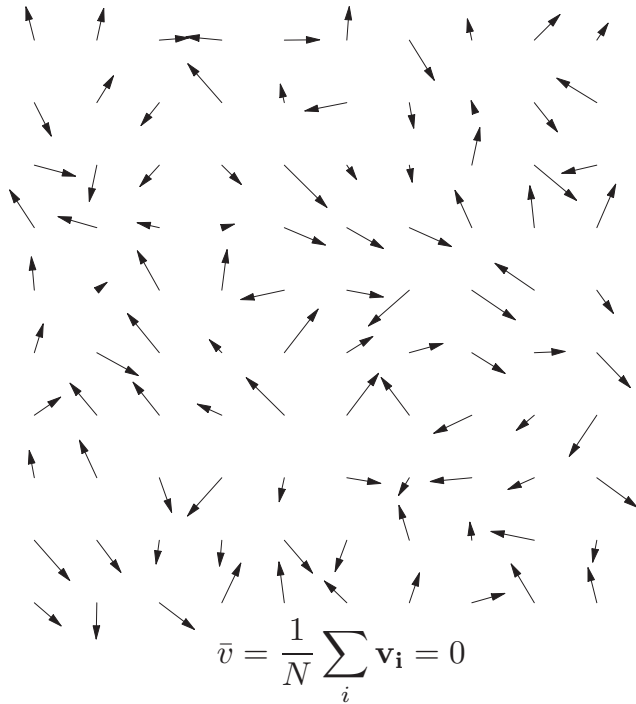

- The above result emphasizes that current is associated with motion. In our simple example, we assumed all carriers move at a velocity v . In reality, as you may know, electrons move very rapidly in random directions due to thermal motion ($mv^2 \sim kT$) and v is the net *drift velocity*.

Aside: Conservation of Charge

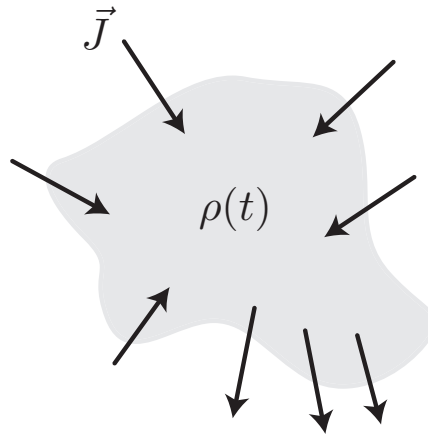

- We know from fundamental physics that charge is conserved. That means that if in a given region the charge is changing in time, it must be due the net flow of current into that region. This is expressed by the current continuity relation in physics (which can be derived from Maxwell's equations)

$$\nabla \cdot \mathbf{J} = -\frac{\partial \rho}{\partial t}$$

- The divergence is an expression of spatial variation of current density whereas the right-hand-side is the change in charge density at a given point.

DC versus AC Currents

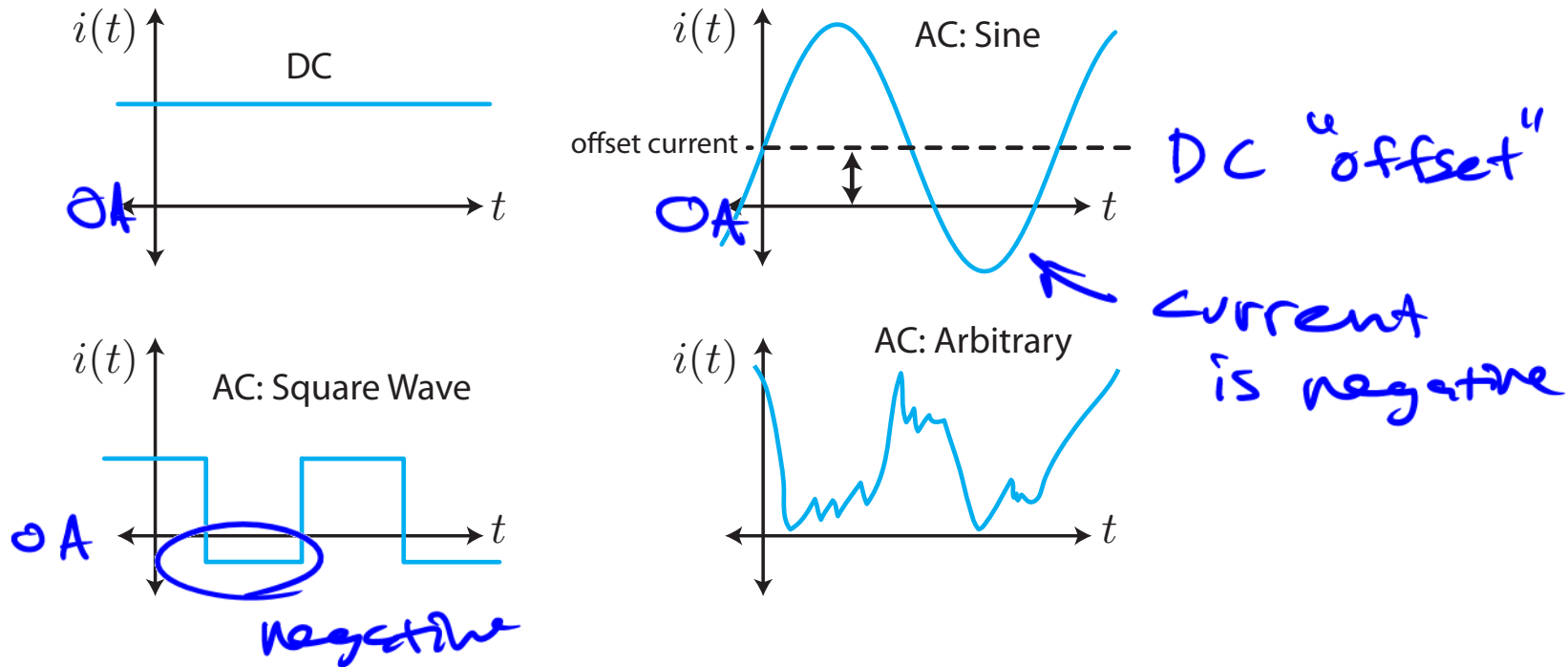

- A constant current is called a "Direct Current" (DC). Otherwise it's AC.
- Some AC typical waveforms are shown above. Sine waves are the waveforms coming out of an electric outlet. A square wave is the clock signal in a digital circuit.
- Any time-varying current is known as an AC, or alternating current. Note that the sign of the current does not necessarily have to change (the current does not have to alter direction), as the name implies.

Current Flow Through a Component

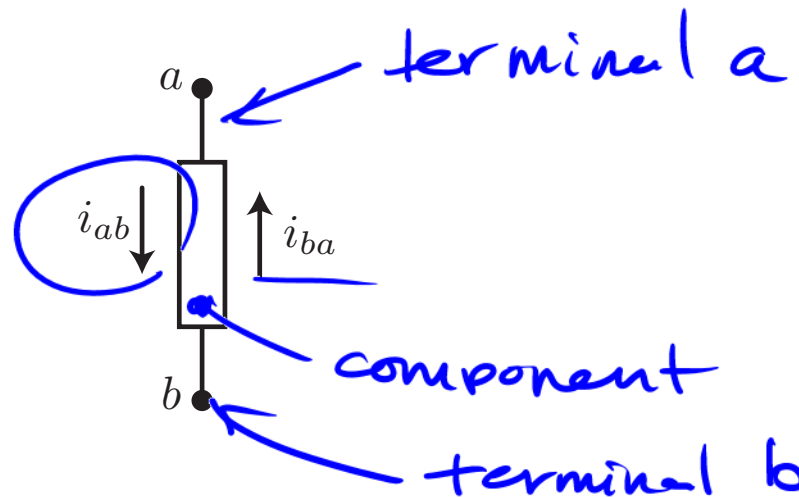

- When current flows into a component (resistor, lamp, motor) from node a to b , we call this current i_{ab} . Note that the current i_{ab} is the same as $-i_{ba}$.
- When several components are connected in a circuit, we call the components branches and associate a current with each branch.

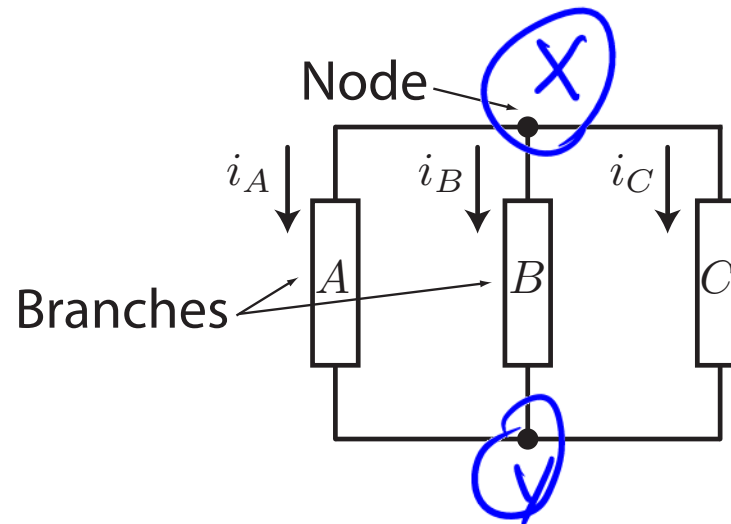

Current into a Component

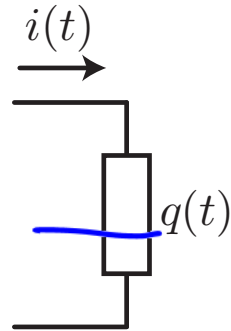

- Suppose that we now consider the current flow into a component. If we count the amount of charge Δq flowing into the component in a time interval Δt , then in the limit as $\Delta t \rightarrow 0$, the ratio is exactly the current flowing into the component

$$I = \lim_{\Delta t \rightarrow 0} \frac{\Delta q}{\Delta t} = \frac{dq}{dt}$$

Voltage

$$V_{AB} = \frac{U_{AB}^x}{Q_x}$$

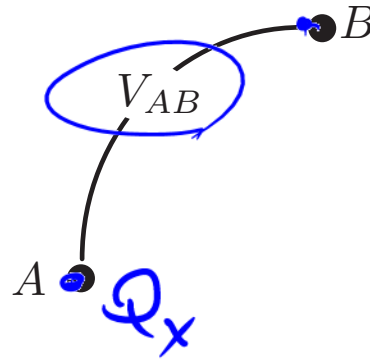

U_{AB} : ENERGY IT TAKES TO GO FROM A TO B

- The voltage difference V_{AB} between A and B is the amount of energy gained or lost per unit of charge in moving between two points.
- Voltage is a relative quantity. An absolute voltage is meaningless and usually is implicitly referenced to a known point in the circuit (ground) or in some cases a point at infinity.
- If a total charge of Δq is moved from $A \rightarrow B$, the energy required is

$$E = \Delta q V_{AB}$$

- If the energy is positive, then by definition energy is gained by the charges as they move “downhill”. If the energy is negative, then energy must be supplied externally to move the charges “uphill”.
- The units of voltage are Volts (after the Italian physicist Alessandro Volta), or Joules/Coulomb.

Voltage Across a Component

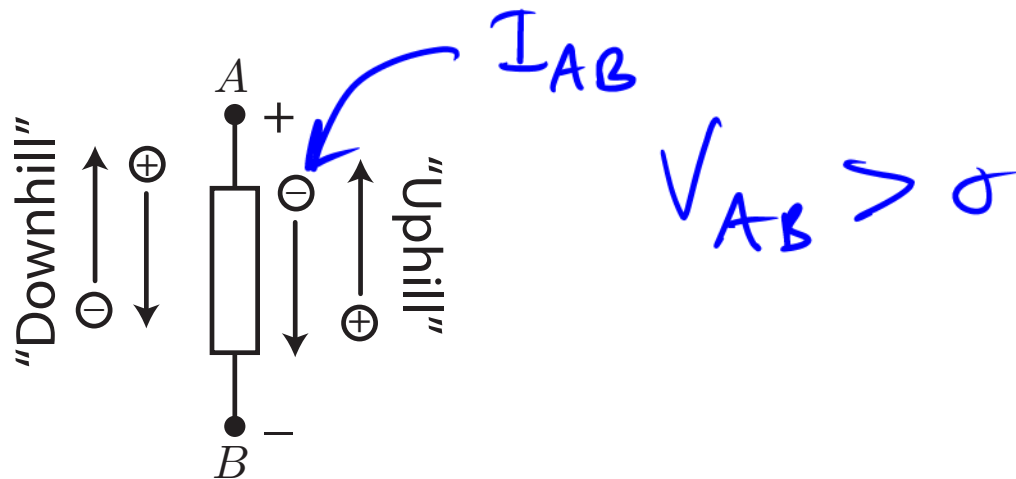

- In electrical circuits, the path of motion is well defined by wires/circuit components (also known as elements). We usually label the terminals of a component as positive and negative to denote the voltage drop across the component.
- Sometimes we don't know the actual polarity of the voltage but we just define a reference direction. In our subsequent calculations, we may discover that we were wrong and the voltage will turn out to be negative. This is easy to detect since $V_{AB} = -V_{BA}$.
- By convention, when current flows into the positive terminal of a component, we say the current is positive. Otherwise the current is negative.

The Concept of Ground

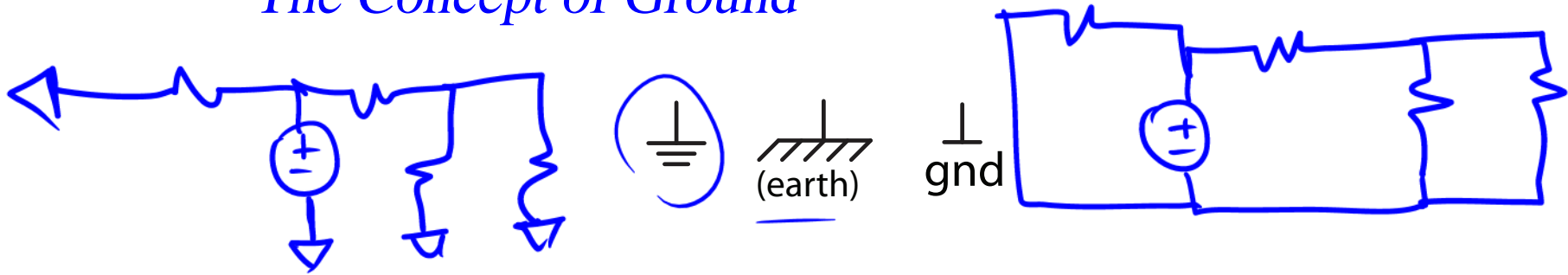

- It is common to use the ground symbol, shown above, to simplify electrical circuits. All voltages are implicitly referenced to the ground terminal.
- In reality, this “ground” may have a physical form, such as the earth ground, or chassis on an automobile, or a large conductor plane in an electric circuit. The requirement is that all points connected to ground should be at the same voltage, in other words ground is an equipotential surface.
- This concept is of course an idealization, since no matter how conductive the ground is made, if enough current flows through the ground, then different points can be at different potentials. But usually this potential difference is smaller than the voltage drops in the circuit elements.
- The concept of ground also breaks down at high frequencies and must be handled with care. Take EE 117 if you’re interested!

→ ground is one point in your circuit (node)

— An object that is very conductive can act like an ideal ground if it's an equipotential body

Jumping A Battery

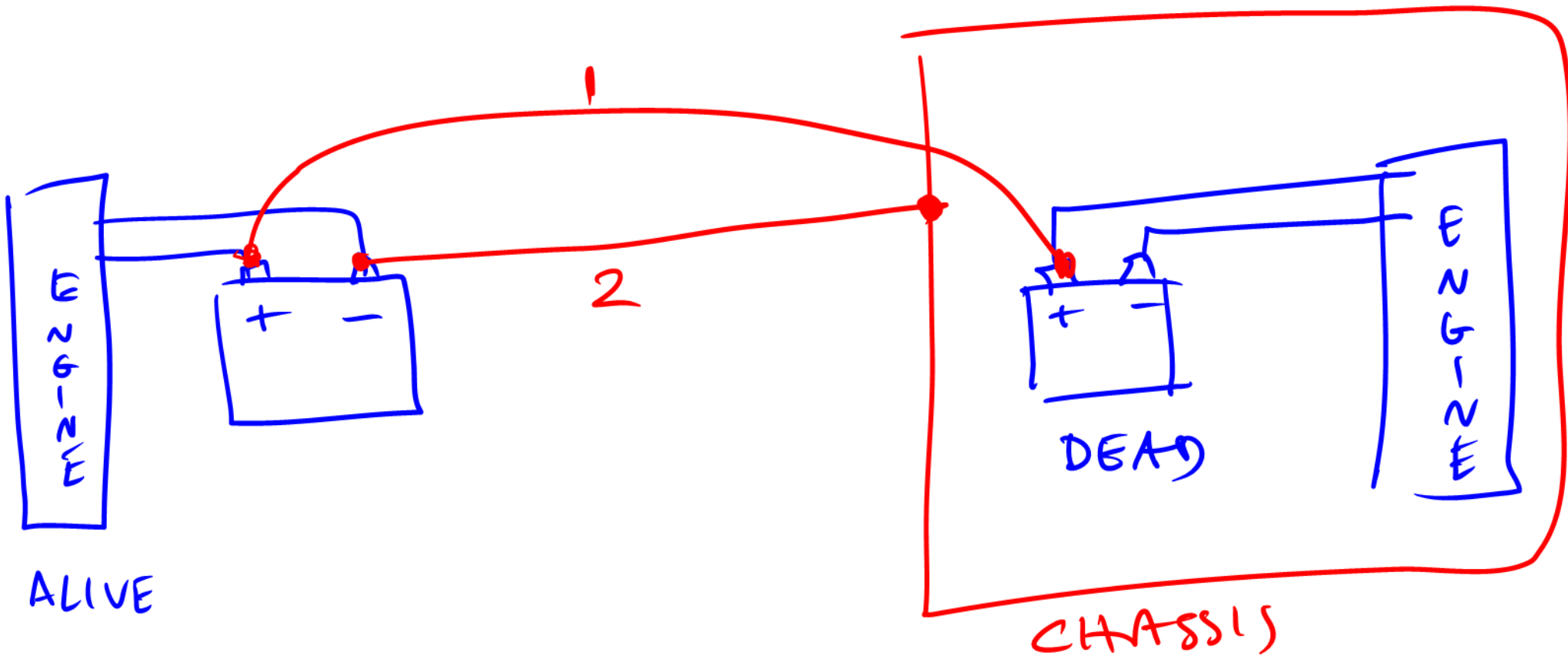

An Ideal Switch

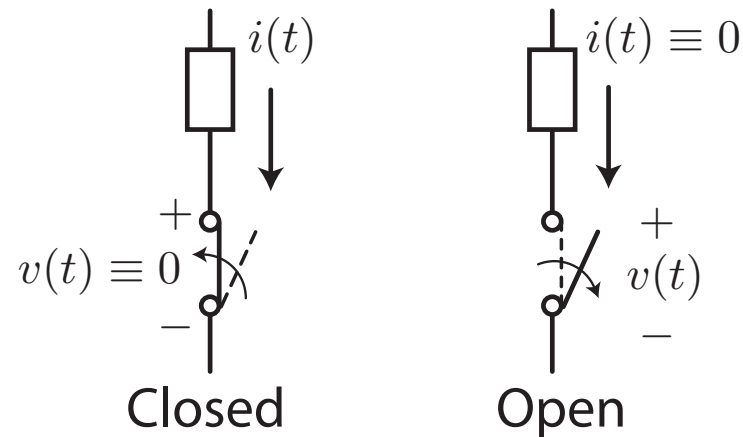

- When an ideal switch is open (off), the flow of current is interrupted and $I \equiv 0$. When an ideal switch is closed (on), then current flows readily through the switch but the voltage across the switch is zero, $V \equiv 0$.
- In a fluid flow analogy, the switch is a valve with only two stages, "on" and "off".

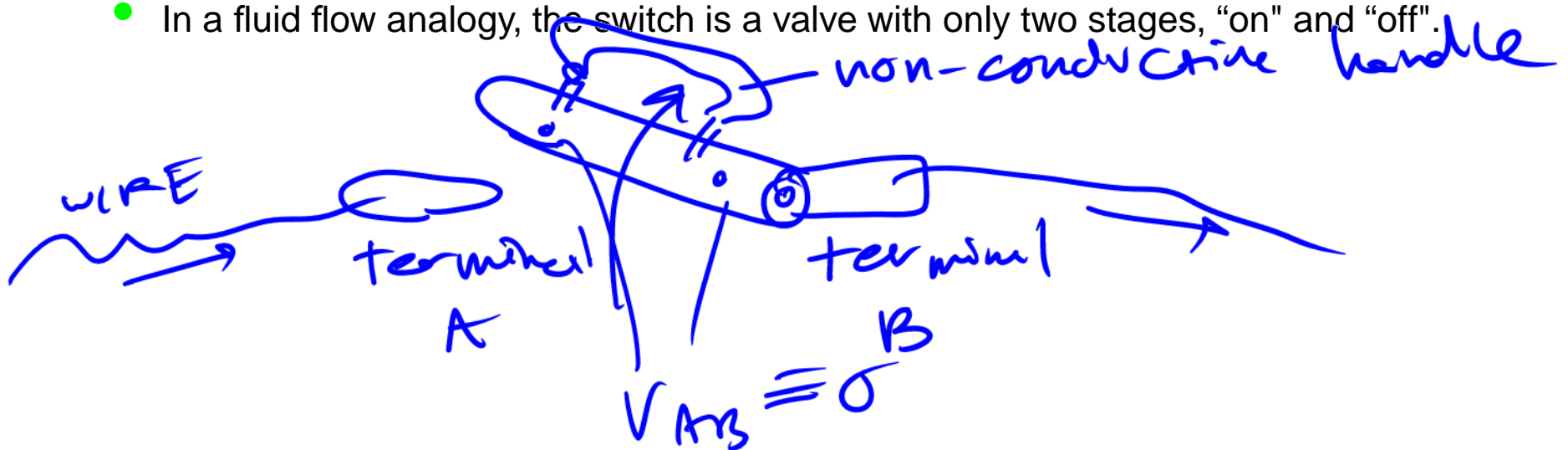

Battery

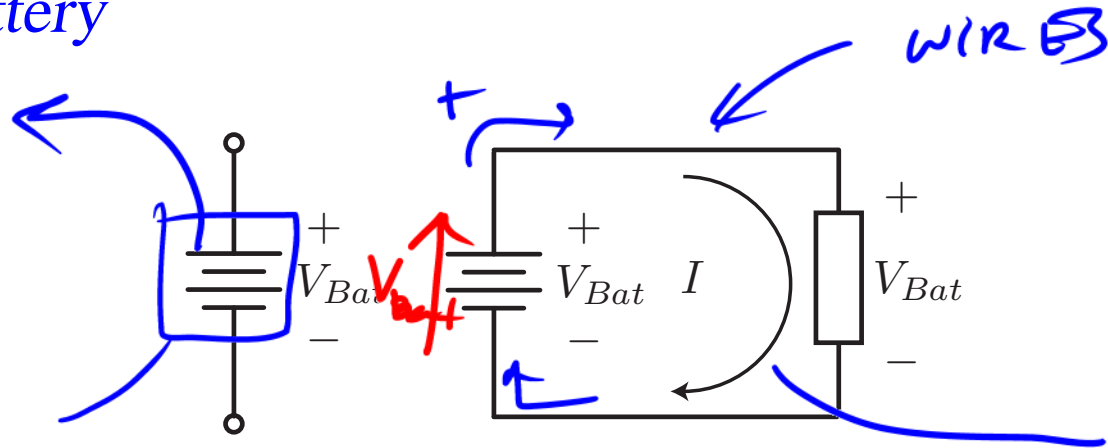

Battery IS DISCHARGING

- A battery can supply energy to a circuit by converting stored chemical energy into electrical energy. It has a fixed voltage across its terminals and can support any current.
- Note that in the above schematic, the direction of the current flow is negative through the battery, indicating that charge carriers gain energy when moving through a battery. On the other hand, current flowing through the component is positive.

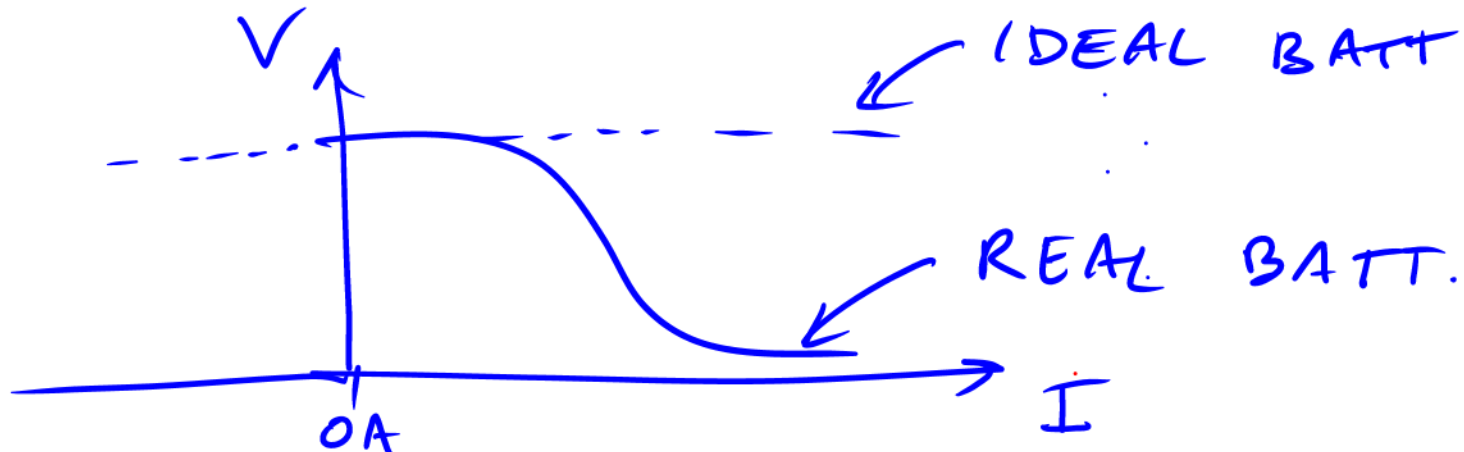

Ski Lift Analogy

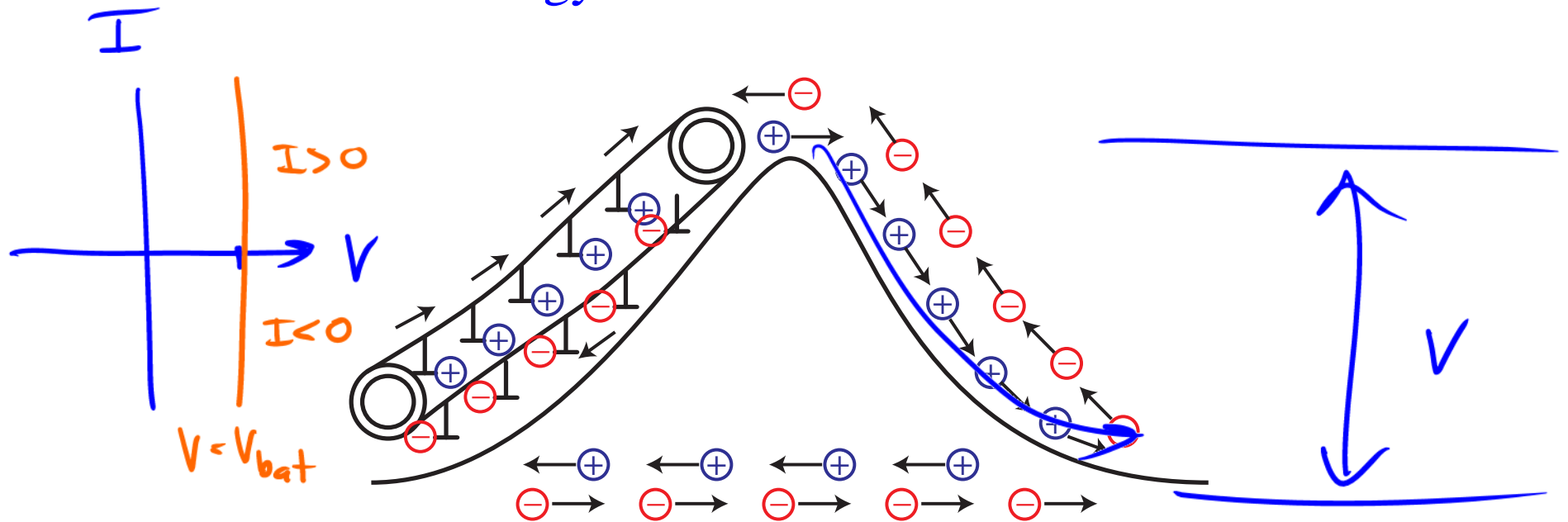

- A cartoon picture of a battery is shown above. Note that the ski lift moves positive charges uphill and negative charges downhill. Positive charges then ski downhill whereas negative charges ski uphill.
- The “voltage” of the battery is fixed regardless of the current, which means the ski lift is capable of running at any speed. The speed is determined by how fast the charges ski down (up) the hill.

Power and Energy

- By definition $\Delta E = V \Delta q$. We like to use a small charge Δq because we don't want to disturb the system. In other words, V itself is a function of charge, so let's assume we use a very small amount of charge.
- Then the power is simply the time rate of change of energy

$$P = \lim_{\Delta t \rightarrow 0} \frac{\Delta E}{\Delta t} = V \lim_{\Delta t \rightarrow 0} \left(\frac{\Delta q}{\Delta t} \right) = V \times I$$

- As expected, the units of $[P] = [V][I] = [J/C][C/s] = [J/s] = [W]$
- The instantaneous power $p(t) = v(t)i(t)$ is the power dissipated (positive) or supplied (negative) by a component with voltage $v(t)$ with current $i(t)$.

$$p(t) > 0$$

COMPONENT IS
ABSORBING ENERGY

$$p(t) < 0$$

COMPONENT IS
SUPPLYING ENERGY

Example 1: Power Through a Component

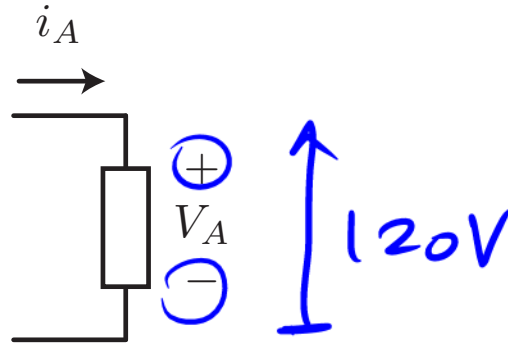
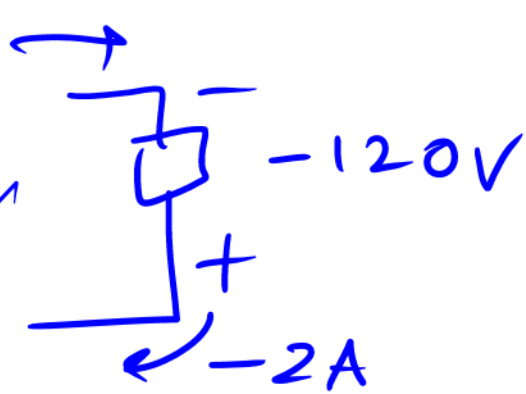

- Suppose a component has a measured voltage of $V_A = 120\text{V}$ across its terminals while supporting a current $i_A = 2\text{A}$ through it. What is the power dissipated in the component?
- Given that the current flows into the positive terminal of the component, then

$$P_A = V_A \cdot i_A = 240\text{W} > 0$$

- Note that the component is absorbing power. Due to conservation of energy, the power is converted into other forms (such as heat or mechanical energy).
- A lamp converts electrical energy into light and heat. A motor converts electrical energy into mechanical energy.

$$P = (-120\text{V}) \times (-2\text{A}) = 240\text{W} > 0$$

Example 2: Power Through Another Component

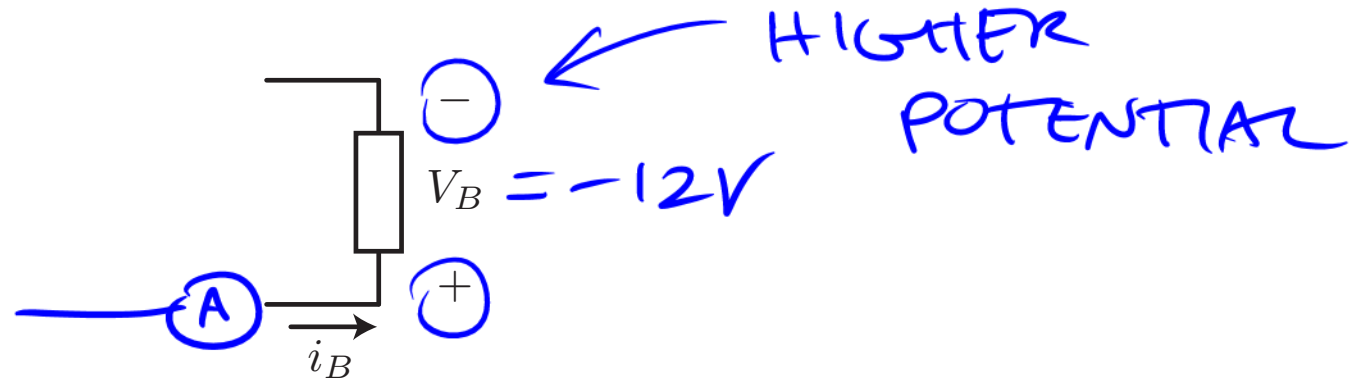

- Suppose another component has a measured voltage of $V_B = -12V$ across its terminals while supporting a current $i_B = 5mA$ through it. What is the power dissipated in the component?
- Given that the current flows into the positive terminal of the component, then

$$P_A = \underline{V_B} \cdot \underline{i_B} = \underline{-60mW} < 0$$

- Note that the component is absorbing negative power, or in other words it's supplying power. Due to conservation of energy, the power must be coming from another source (chemical or mechanical, for example).

Example 3: Instantaneous Power

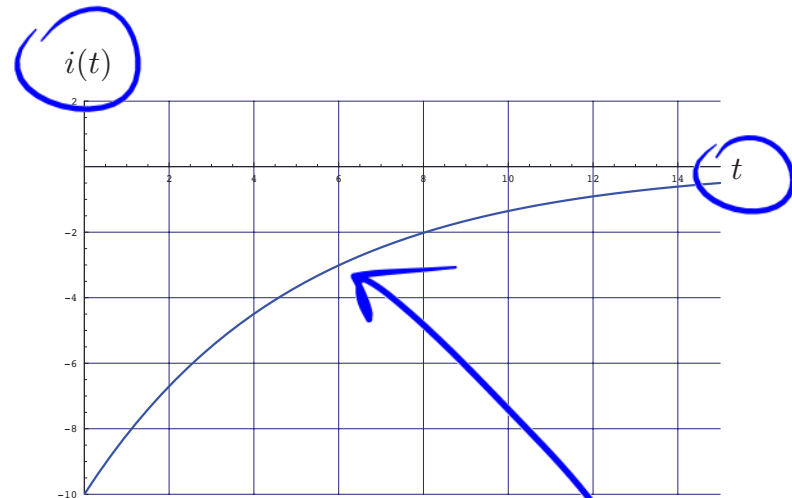
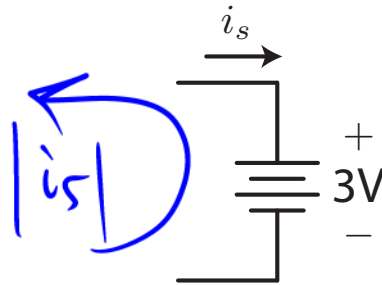

- Suppose a 3V voltage source has an instantaneous current of $i_s(t) = -10e^{-t/5\text{ns}}$ mA, as shown above for $t > 0$. Find the net energy supplied by the source
- Given that the current flows into the positive terminal of the component, then

$$p_s(t) = 3\text{V} \cdot i_s(t)$$

- If we integrate the power over time, we arrive at the net power supplied in this interval (note that $i(t) < 0$ for all time so the power always flows out of the source)

$$\begin{aligned} \underline{E_s} &= \int_0^\infty \underline{p_s(t)} dt = -30\text{mW} \int_0^\infty e^{-t/\tau} dt = \frac{+30\text{mW}}{1/\tau} (e^{-\infty} - e^0) \\ &= -30\text{mW} \times 5\text{nsec} = \underline{-150\text{pJ}} \end{aligned}$$

An Aside on Common SI Prefixes

Prefix	10^n	Symbol
tera	10^{12}	T
giga	10^9	G
mega	10^6	M
kilo	10^3	k
centi	10^{-2}	c
milli	10^{-3}	m
micro	10^{-6}	μ
nano	10^{-9}	n
pico	10^{-12}	p
femto	10^{-15}	f
atto	10^{-18}	a

- We commonly use the above SI prefixes in electrical engineering. The only one you may not have seen before is a, or atto, which came into common use as components in integrated circuits became small enough to require this prefix to describe units such as capacitance.

Example 4: An Ideal Switch / A Short Circuit

- An ideal switch cannot absorb power because in either state, the voltage or current is zero so $p(t) \equiv 0$.
- An ideal wire is an equipotential surface, and so it cannot support a voltage from one end to the other. The power dissipated by an ideal wire is also zero.
- An ideal wire is also called a “short circuit”, especially when placed from one point to the other, we say the nodes are “shorted”.

KCL: Kirchoff's Current Law

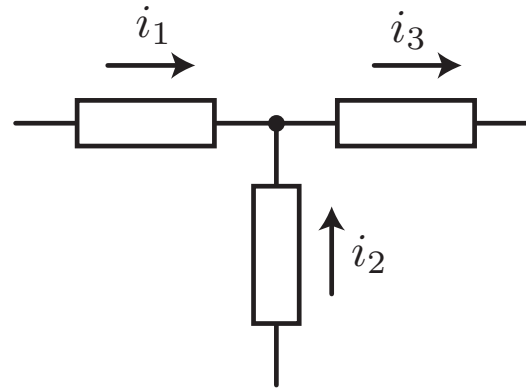

- KCL states that the net charge flowing into any node of a circuit is identically zero. In the example shown

$$i_1 + i_2 - i_3 = 0$$

- The reason for this is clear from the flow nature of current. Some of the currents flow in, some flow out, but in the net all must balance out.
- A direct implication of KCL is that series elements have equal currents, $i_A = i_B$.



Aside: Origin of KCL

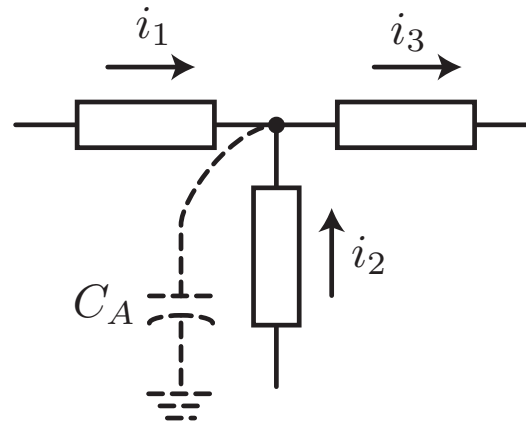

- KCL is related to charge conservation. Note that this is just a re-statement of current continuity $\nabla \cdot \mathbf{J} = -\frac{\partial \rho}{\partial t}$.
- If the net current is not zero, then somehow charge must be accumulating at a node. This can only happen if the node in question has some capacitance (say to ground). But such a capacitance can always be included as a separate component (come back and re-read this after we define capacitance!). So if we say that the node has zero capacitance, or $C_A \equiv 0$, then KCL makes sense.

KVL: Kirchoff's Voltage Law

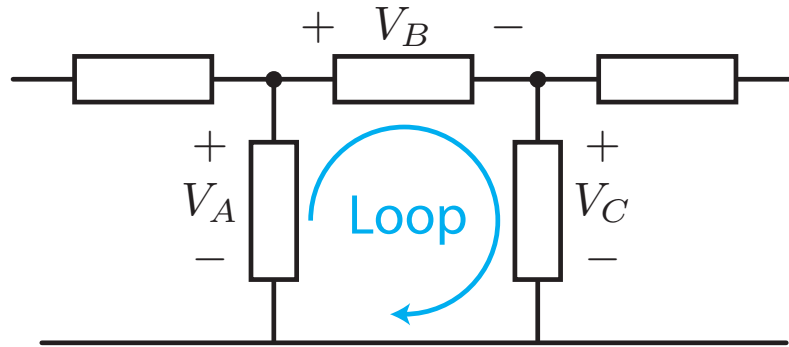

- KVL states that the net potential around any loop in a circuit is zero

$$\sum_{Loop} V_k = 0$$

- Or more explicitly, for the example shown, $-V_A + V_B + V_C = 0$. In other words, the net energy in going around a loop is zero.
- Notice that if we had defined the loop in the opposite direction, then we have: $V_A - V_C - V_B = 0$, or by multiplying the equation by -1 , the same relation.

Aside: E&M Connection

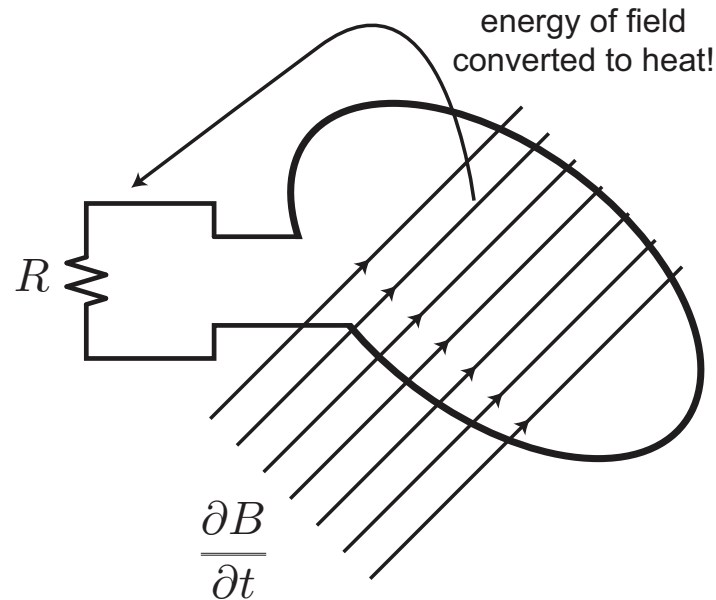

- This makes sense if the voltage arises from electrostatic sources, which leads to a conservative field. Then if we calculate the net energy in traversing any closed path, including any loop in a circuit, it must be zero since we return to the same point.
- You may be wondering about a non-electrostatic situation in which the field is not conservative. In this situation, if there is a changing magnetic field crossing the loop (such as in a motor), then energy can be transferred into or out of the circuit. This can be represented as coupled inductors linking the loop to other circuitry, a detail which we will ignore in this class.

KVL Implications

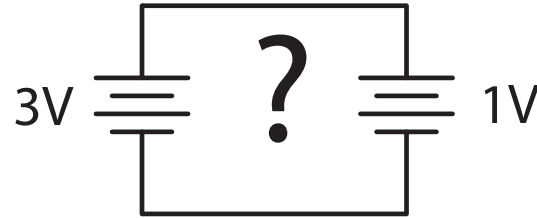

- All shunt (or parallel) components have the same voltage.
- This is why you should *never* connect batteries in parallel (It violates KVL). Since each one has a fixed potential across its terminals, it is simply not possible to do this. In practice, a large current would flow from the higher voltage battery to the lower one, possibly burning the wires connecting them. The magnitude of the current is limited by the internal resistances of the batteries (come back and re-read this after we talk about resistance).