

Integrated Circuits for Communication



Berkeley

Transmission Lines in the Frequency Domain

Prof. Ali M. Niknejad

U.C. Berkeley
Copyright © 2025 by Ali M. Niknejad

February 3, 2025

Why Sinusoidal Steady-State?

Time Harmonic Steady-State

- Compared with general transient case, sinusoidal case is very easy $\frac{\partial}{\partial t} \rightarrow j\omega$
- Sinusoidal steady state has many important applications for RF/microwave circuits
- At high frequency, T-lines are like interconnect for distances on the order of λ
- Shorted or open T-lines are good resonators
- T-lines are useful for impedance matching

Why Sinusoidal Steady-State?

- Typical RF system modulates a sinusoidal carrier (either frequency or phase). If the modulation bandwidth is much smaller than the carrier, the system looks like it's excited by a pure sinusoid
- Cell phones are a good example. Say the carrier frequency of **1 GHz** and the voice digital modulation is about **200 kHz**(GSM) or **1.25 MHz**(CDMA), less than a 0.1% of the bandwidth/carrier
- Even a system like WiFi grabbing multiple channels might be 80 MHz wide, so over a 5 GHz carrier, it's still a small fractional bandwidth.
- 5G cellular systems have even wider bandwidths for higher data rates, but again the carrier is moved to a higher frequency. So even a whopping 800 MHz of bandwidth at 28 GHz is still “narrowband” (**< 3%**)

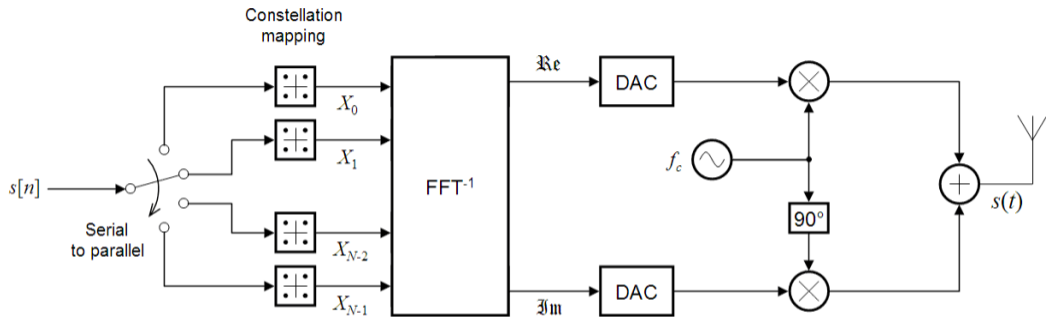

https://upload.wikimedia.org/wikipedia/commons/4/4e/OFDM_transmitter_ideal.png

- To combat multi-path and frequency selective fading, multi-carrier modulation schemes are used (OFDM used by both WiFi and 4G/ LTE/5G), and each carrier is modulated in a very narrowband fashion.

Generalized Distributed Circuit Model

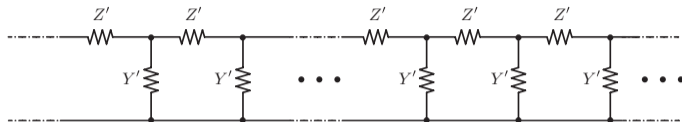

- Z' : impedance per unit length (e.g. $Z' = j\omega L' + R'$)
- Y' : admittance per unit length (e.g. $Y' = j\omega C' + G'$)
- A lossy T-line might have the following form (but we'll analyze the general case)

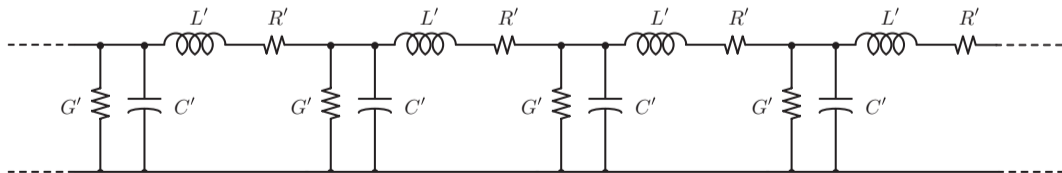

Telegrapher's Eq. Again

- Applying KCL and KVL to a infinitesimal section

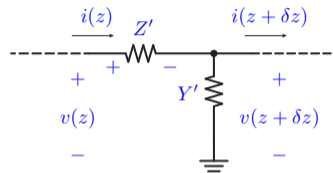

- Taking the limit as before ($\delta z \rightarrow 0$)

Sin. Steady-State Voltage/Current

- Taking derivatives (notice z is the only variable) we arrive at
- Where the propagation constant γ is a complex function
- The general solution to $D^2G - \gamma^2G = 0$ is $e^{\pm\gamma z}$

Lossless Lines

Lossless Line for Sinusoidal Steady State

- The voltage and current are related (just as before, but now easier to derive).
 $Z_0 = \sqrt{\frac{Z'}{Y'}}$ is the characteristic impedance of the line (function of frequency with loss).
- For a lossless line we discussed before, $Z' = j\omega L'$ and $Y' = j\omega C'$. Propagation constant is imaginary

- The characteristic impedance is real: $Z_0 = \sqrt{\frac{L'}{C'}}$
- β is like the spatial frequency, also known as the wave number
- You might prefer to think of it in terms of wavelength λ , $\beta = \frac{2\pi}{\lambda}$

- Recall that the *real* voltages and currents are the \Re and \Im parts of
- Thus the voltage/current waveforms are sinusoidal in space and time
- Sinusoidal source voltage is transmitted unaltered onto T-line (with delay)
- If there is loss, then γ has a real part α , and the wave decays or grows on the T-line
- The first term represents amplitude response of the T-line

Passive T-Line/Wave Speed

- For a passive line, we expect the amplitude to decay due to loss on the line
- The speed of the wave is derived as before. In order to follow a constant point on the wavefront, you have to move with velocity

- Or, $v = \frac{dz}{dt} = \pm \frac{\omega}{\beta} = \pm \sqrt{\frac{1}{L'C'}}$

Lossless T-Line Termination

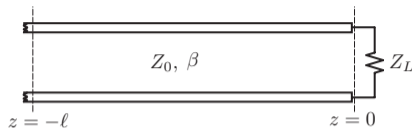

- Okay, lossless line means $\gamma = j\beta$ ($\alpha = 0$), and $\Im(Z_0) = 0$ (real characteristic impedance independent of frequency)
- The voltage/current phasors take the standard form

Animations: Traveling and Standing Waves on a T-Line

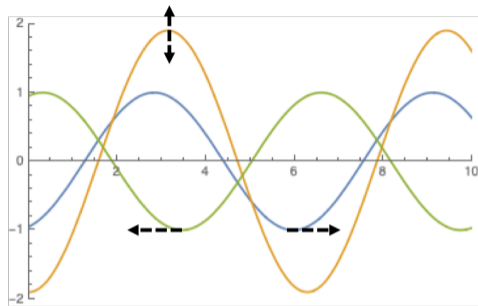
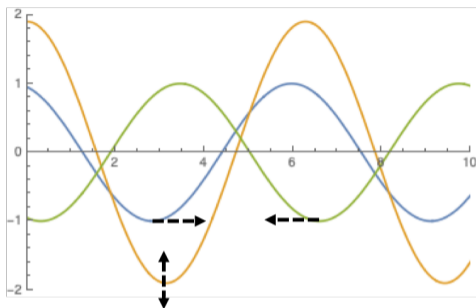

- Simple Sine Wave (no reflection): [[click](#)]
- If the reflected wave has the same magnitude as the incident wave, the familiar standing wave pattern emerges.
- Standing Wave (reflection equal to incident wave): [[click](#)]

Animations: Incident and Reflected Wave

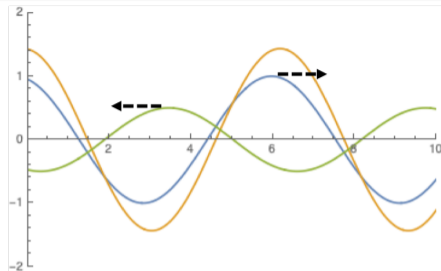
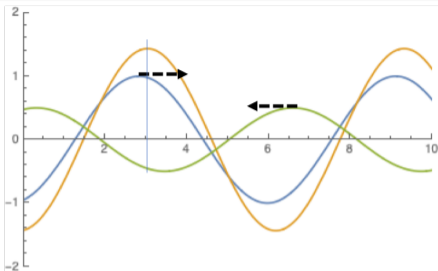

- Now suppose the reflected wave is weaker by a factor of ρ , where $|\rho| < 1$.
- Sine wave plus reflection [\[click\]](#)
- Notice that there's energy flow to the right and left, but the energy flow to the right dominates
- This produces a weaker flow to the right and a standing wave pattern. It's as if the standing wave is moving, but this is an illusion ...

Standing and Traveling Wave Decomposition

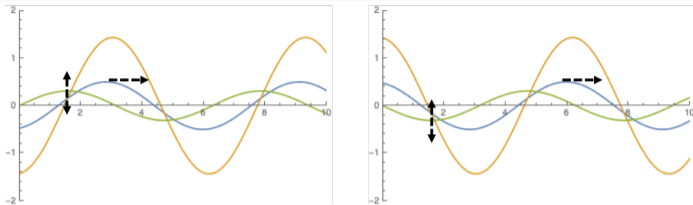

- Sine wave plus reflection recomposed as traveling wave and standing wave [[click](#)]

- Please see animations. Otherwise it won't make sense !

$$\underbrace{2V_0\rho \cos(\omega t) \sin(\beta z)} \quad \underbrace{(1 - \rho) \sin(\omega t - \beta z)}$$

Standing Waves and VSWR

Power on T-Line (I)

- Let's calculate the average power dissipation on the line at point z

- Or using the general solution

- The product in the \Re terms can be expanded into four terms

$$\underbrace{\rho_L e^{2j\beta z} - \rho_L^* e^{-2j\beta z}}$$

- Notice that $a - a^* = 2j\Im(a)$

Power on T-Line (II)

- The average power dissipated at z is therefore
- Power flow is constant (independent of z) along line (lossless)
- No power flows if $|\rho_L| = 1$ (open or short)
- Even though power is constant, voltage and current are not!

Voltage along T-Line

- When the termination is matched to the line impedance $Z_L = Z_0$, $\rho_L = 0$ and thus the voltage along the line $|v(z)| = |V^+|$ is constant. Otherwise

- The voltage magnitude along the line can be written as

- The voltage is maximum when the $2\beta\ell$ is equal to $\theta + 2k\pi$, for any integer k ; in other words, the reflection coefficient phase modulo 2π

Voltage along T-Line

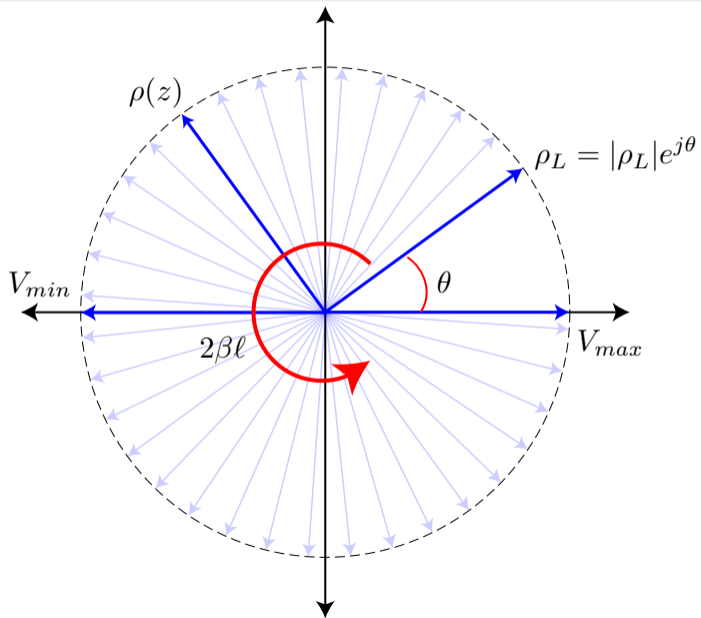

Voltage Standing Wave Ratio (SWR)

- Similarly, minimum when $\theta + k\pi$, where k is an integer $k \neq 0$
- The ratio of the maximum voltage to minimum voltage is an important metric and commonly known as the voltage standing wave ratio, VSWR (sometimes pronounced viswar), or simply the standing wave ratio SWR
- It follows that for a shorted or open transmission line the VSWR is infinite, since $|\rho_L| = 1$.

- Physically the maxima occur when the reflected wave adds in phase with the incoming wave, and minima occur when destructive interference takes place. The distance between maxima and minima is π in phase, or $2\beta\delta x = \pi$, or
- VSWR is important because it can be deduced with a *relative* measurement. Absolute measurements are difficult at microwave frequencies. By measuring VSWR, we can readily calculate $|\rho_L|$.

- By measuring the location of the voltage minima from an unknown load, we can solve for the load reflection coefficient phase θ
- Note that
- Thus an unknown impedance can be characterized at microwave frequencies by measuring VSWR and ℓ_{min} and computing the load reflection coefficient. This was an important measurement technique that has been largely supplanted by a modern network analyzer with built-in digital calibration and correction.

- Consider a transmission line terminated in a load impedance $Z_L = 2Z_0$. The reflection coefficient at the load is purely real
- Since $1 + |\rho_L| = 4/3$ and $1 - |\rho_L| = 2/3$, the VSWR is equal to 2.
- Since the load is real, the voltage minima will occur at a distance of $\lambda/4$ from the load

Impedance of T-Lines (“Ohm’s Law in Freq Domain”)

Impedance of T-Line (I)

- We have seen that the voltage and current along a transmission line are altered by the presence of a load termination. At an arbitrary point z , wish to calculate the input impedance, or the ratio of the voltage to current relative to the load impedance Z_L
- It shall be convenient to define an analogous reflection coefficient at an arbitrary position along the line

Impedance of T-Line (II)

- $\rho(z)$ has a constant magnitude but a periodic phase. From this we may infer that the input impedance of a transmission line is also periodic (relation between ρ and Z is one-to-one)
- The above equation is of paramount importance as it expresses the input impedance of a transmission line as a function of position ℓ away from the termination.

Impedance of T-Line (III)

- This equation can be transformed into another more useful form by substituting the value of ρ_L

Using the common complex expansions for sine and cosine, we have

Impedance of T-Line (IV)

- The expression for the input impedance is now written in the following form
- This is the most important equation of the lecture, known sometimes as the “transmission line equation”

- The shorted transmission line has infinite VSWR and $\rho_L = -1$. Thus the minimum voltage $V_{min} = |V^+|(1 - |\rho_L|) = 0$, as expected. At any given point along the transmission line

whereas the current is given by

or

Shorted Line Impedance (I)

- The impedance at any point along the line takes on a simple form
- This is a special case of the more general transmission line equation with $Z_L = 0$.
- Note that the impedance is purely imaginary since a shorted lossless transmission line cannot dissipate any power.
- We have learned, though, that the line stores reactive energy in a distributed fashion.

Shorted Line Impedance (II)

- A plot of the input impedance as a function of z is shown below

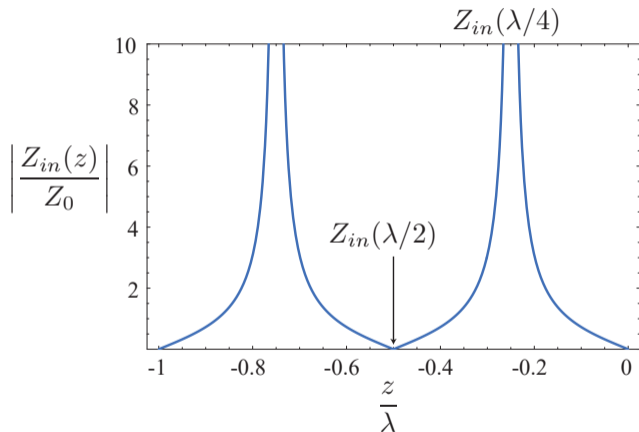

- The tangent function takes on infinite values when $\beta \ell$ approaches $\pi/2$ modulo 2π

Shorted Line Impedance (III)

- Shorted transmission line can have infinite input impedance!
- This is particularly surprising since the load is in effect transformed from a short of $Z_L = 0$ to an infinite impedance.
- A plot of the voltage/current as a function of z is shown below

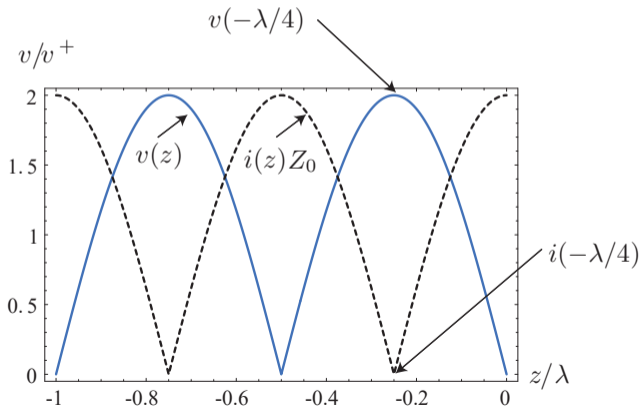

Shorted Line Reactance

- $l \ll \lambda/4 \rightarrow$ inductor
- $l < \lambda/4 \rightarrow$ inductive reactance
- $l = \lambda/4 \rightarrow$ open (acts like resonant parallel LC circuit)
- $l > \lambda/4$ but $l < \lambda/2 \rightarrow$ capacitive reactance
- And the process repeats
...

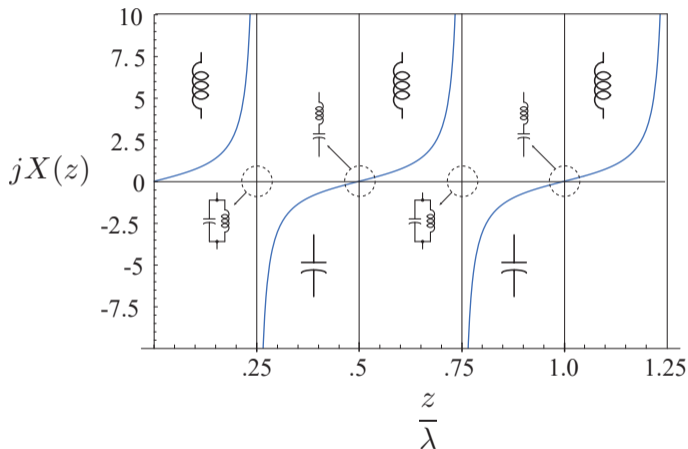

- The open transmission line has infinite VSWR and $\rho_L = 1$. At any given point along the transmission line

whereas the current is given by

or

Open Line Impedance (I)

- The impedance at any point along the line takes on a simple form
- This is a special case of the more general transmission line equation with $Z_L = \infty$.
- Note that the impedance is purely imaginary since an open lossless transmission line cannot dissipate any power.
- We have learned, though, that the line stores reactive energy in a distributed fashion.

Open Line Impedance (II)

- A plot of the input impedance as a function of z is shown below

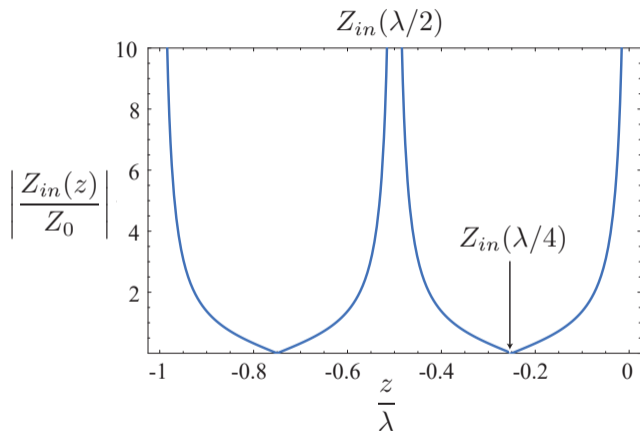

- The cotangent function takes on zero values when βl approaches $\pi/2$ modulo 2π

Open Line Impedance (III)

- Open transmission line can have zero input impedance!
- This is particularly surprising since the open load is in effect transformed from an open
- A plot of the voltage/current as a function of z is shown below

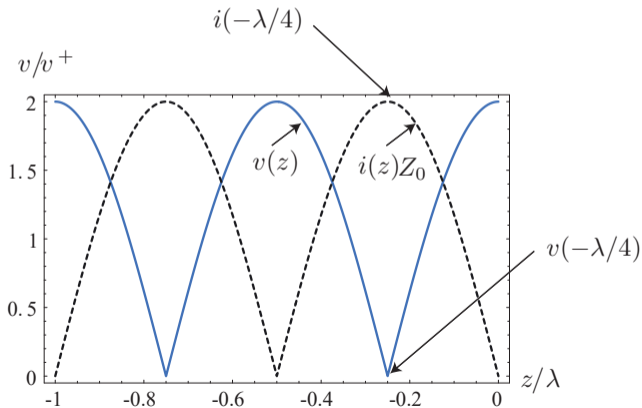

Open Line Reactance

- $l \ll \lambda/4 \rightarrow$ capacitor
- $l < \lambda/4 \rightarrow$ capacitive reactance
- $l = \lambda/4 \rightarrow$ short (acts like resonant series LC circuit)
- $l > \lambda/4$ but $l < \lambda/2 \rightarrow$ inductive reactance
- And the process repeats
...

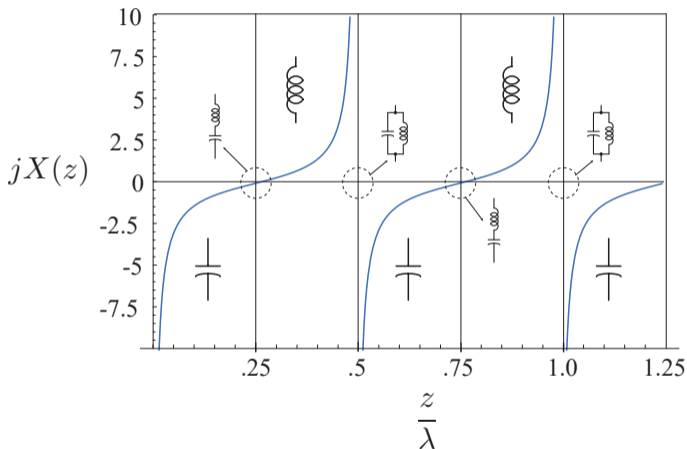

- Plug into the general T-line equation for any multiple of $\lambda/2$
- $\beta\lambda m/2 = \frac{2\pi}{\lambda} \frac{\lambda m}{2} = \pi m$
- $\tan m\pi = 0$ if $m \in \mathcal{Z}$
- $Z_{in}(-\lambda m/2) = Z_0 \frac{Z_L}{Z_0} = Z_L$
- Impedance does not change ... it's periodic about $\lambda/2$ (not λ)

- Plug into the general T-line equation for any multiple of $\lambda/4$
- $\beta\lambda m/4 = \frac{2\pi}{\lambda} \frac{\lambda m}{4} = \frac{\pi}{2} m$
- $\tan m\frac{\pi}{2} = \infty$ if m is an odd integer
- $Z_{in}(-\lambda m/4) = \frac{Z_0^2}{Z_L}$
- $\lambda/4$ line transforms or “inverts” the impedance of the load

Multimode Propagation

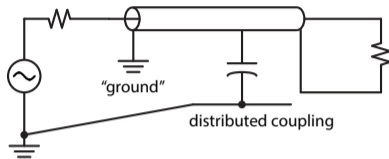

- Up to now, we have assumed that the signal travels along two conductors, one “signal” conductor and one “ground” conductor. Even if we “ground” the second conductor, there’s no reason that it has to stay “grounded”.
- In fact, like it or not, there’s always a third conductor at play. For example, when two wires are routed on a PCB, the ground plane can act as a potential signal return path (so can earth ground). So we really have to consider the possibility of exciting this “common mode” transmission line.

Stripline Example

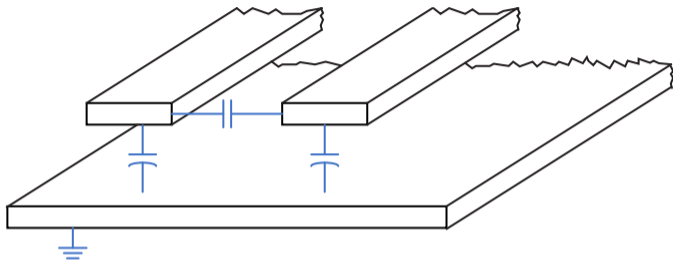

- Here we have two conductors that form a stripline (differential line) but they reside above a ground plane. So each one individually couples to the ground plane and forms another transmission line.
- In general, we must model this secondary transmission line to account properly for the actual signal propagation.

Distributed Model

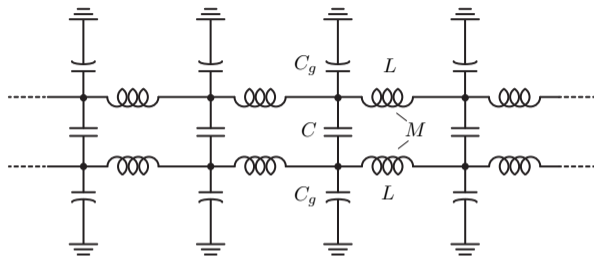

- Each line has distributed inductance and capacitance to the ground as before, but also mutual inductance and capacitance to the other line.
- Note that the return current flowing on the ground plane also contributes to the inductance (mutually coupled to all other conductors) but we can effectively lump the entire loop of signal + ground into one inductance as shown.

Odd Mode Excitement

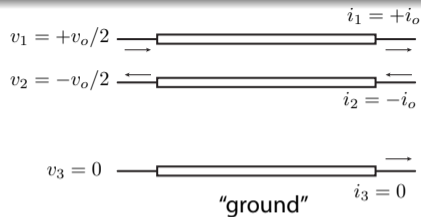

- If we assume that $v_1 = -v_2$, we say we are exciting the odd mode. In this mode, no signal current flows into the ground plane as $i_1 = -i_2$.
- This mode can be excited in a symmetric structure with a differential circuit. Note that if we ground v_2 at the source, we are not exciting *only* the odd mode.
- The propagation constant is given by

Even Mode Excitement

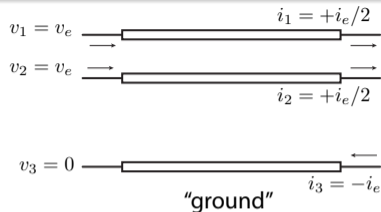

- If we assume that $v_1 = v_2$, we say we are exciting the even mode. In this mode, there is necessarily a signal current flowing into the ground plane.
- This mode can be excited by shorting the two signal conductors together and observing the current flow.
- The propagation constant is given by

General Excitement

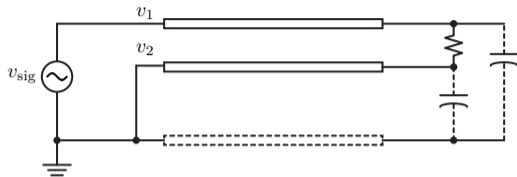

- In general, we can excite both the even and odd modes. For example, if we ground one side of the T-line and drive it as shown in a single-ended fashion, we are exciting both modes
- Note that both even and odd mode is excited in this case.

Example: Quarter Wave Balun

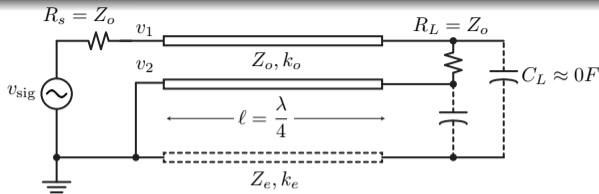

- A transmission line that is $\lambda/4$ can be used as a balun. To see this, let's solve both the even and odd modes for the case that the line is terminated.
- For the odd mode, the boundary condition is clearly determined by the load
- Whereas for the even mode, let's say it's approximately an open circuit

Example: Quarter Wave Balun (2)

- Substituting in the above equations

- Notice that the second terms precisely cancel out at the load since

and

- This implies that the signal at the load side is a pure odd mode, or balanced signal. To achieve this, we desire a high common mode impedance to satisfy $\rho_e \approx 1$.