

**EECS 142**



Integrated Circuits for Communication

## *Lecture 7: Two-Port Circuits*

Prof. Ali M. Niknejad

University of California, Berkeley

Copyright © 2008 by Ali M. Niknejad

# A Generic Amplifier

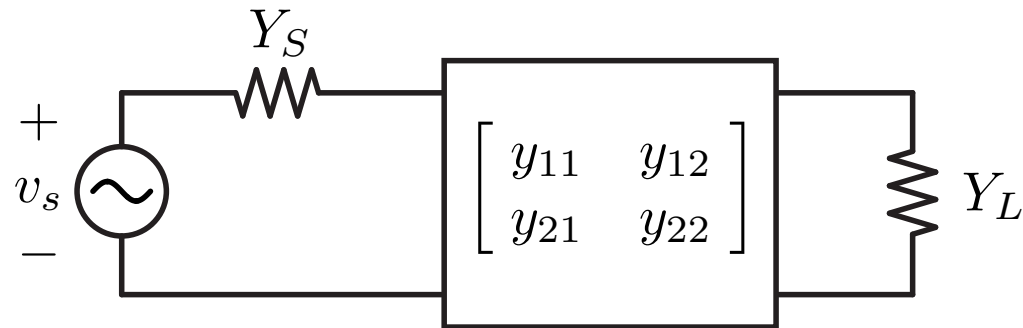

- Consider the generic two-port (e.g. amplifier or filter) shown above. A port is defined as a terminal pair where the current entering one terminal is equal and opposite to the current exiting the second terminal.
- Any circuit with four terminals can be analyzed as a two-port if it is free of independent sources and the current condition is met at each terminal pair.
- All the complexity of the two-port is captured by four complex numbers (which are in general frequency dependent).

# Two-Port Parameters

- There are many two-port parameter set, which are all equivalent in their description of the two-port, including the admittance parameters ( $Y$ ), impedance parameters ( $Z$ ), hybrid or inverse-hybrid parameters ( $H$  or  $G$ ),  $ABCD$ , scattering  $S$ , or transmission ( $T$ ).
- $Y$  and  $Z$  parameters relate the port currents (voltages) to the port voltages (currents) through a 2x2 matrix. For example

$$\begin{pmatrix} v_1 \\ v_2 \end{pmatrix} = \begin{pmatrix} z_{11} & z_{12} \\ z_{21} & z_{22} \end{pmatrix} \begin{pmatrix} i_1 \\ i_2 \end{pmatrix}$$

- Hybrid parameters choose a combination of  $v$  and  $i$ . For example

$$\begin{pmatrix} v_1 \\ i_2 \end{pmatrix} = \begin{pmatrix} h_{11} & h_{12} \\ h_{21} & h_{22} \end{pmatrix} \begin{pmatrix} i_1 \\ v_2 \end{pmatrix}$$

# Two-Port Parameters

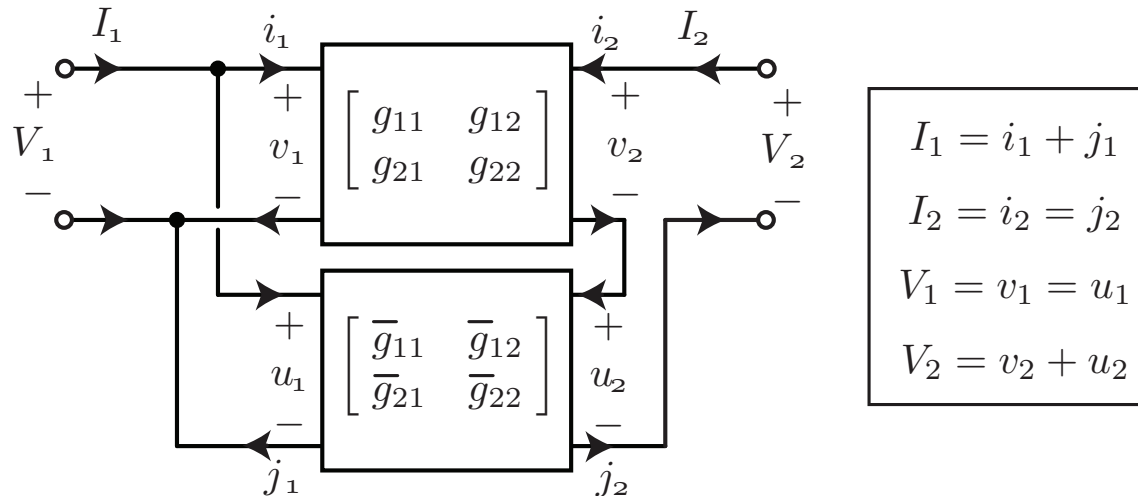

- Notice that a series connection of two two-ports implies the same current flows through both two-ports whereas the voltage across the two-ports is the sum of the individual voltages.
- On the other hand, a shunt connection of two two-ports implies the same voltage is applied across both two-ports whereas the current into the two-ports is the sum of the individual currents.
- These simple observations allow us to simply *sum* two-port parameters for various shunt/series interconnections of two-ports.

# Choosing Two-Port Parameters

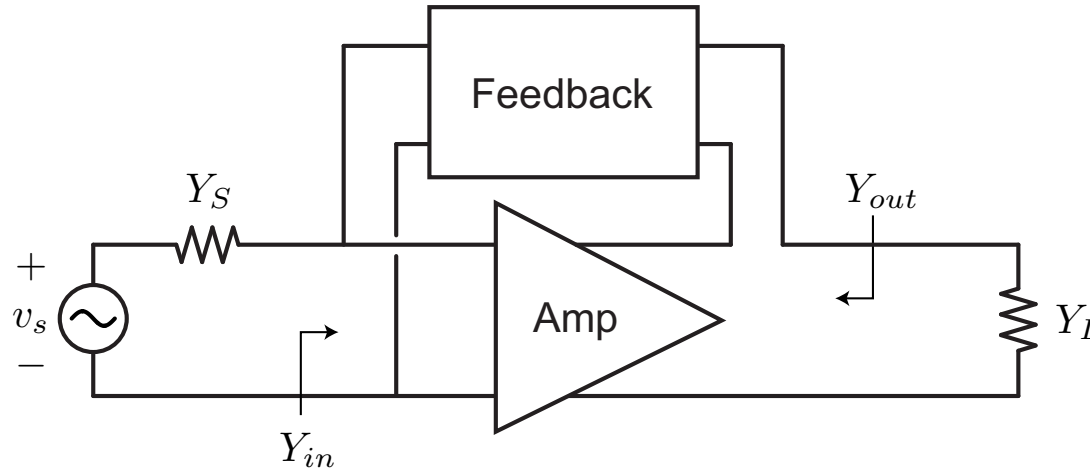

- The choice of parameter set is usually determined by convenience. For instance, if shunt feedback is applied,  $Y$  parameters are most convenient, whereas series feedback favors  $Z$  parameters. Other combinations of shunt/series can be easily described by  $H$  or  $G$ .
- $ABCD$  parameters are useful for cascading two-ports.

# Feedback Example

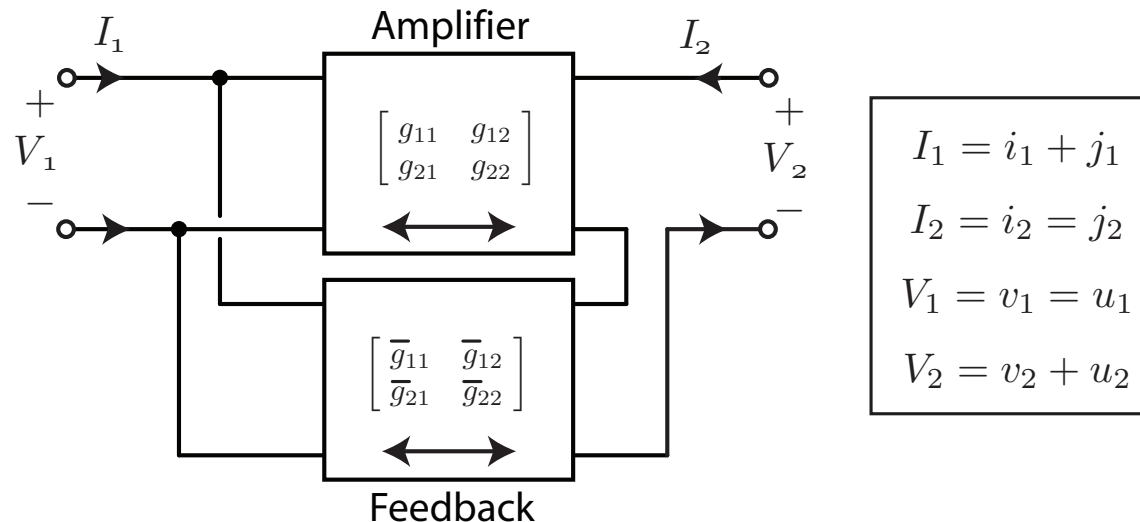

- Any real feedback amplifier is non-ideal due to intrinsic feedback in the amplifier itself (bilateral nature) and the feedforward through the feedback network.
- The feedback network also loads the primary amplifier.
- It's hard to apply ideal signal flow analysis to the real circuit unless...

# Feedback Example (cont)

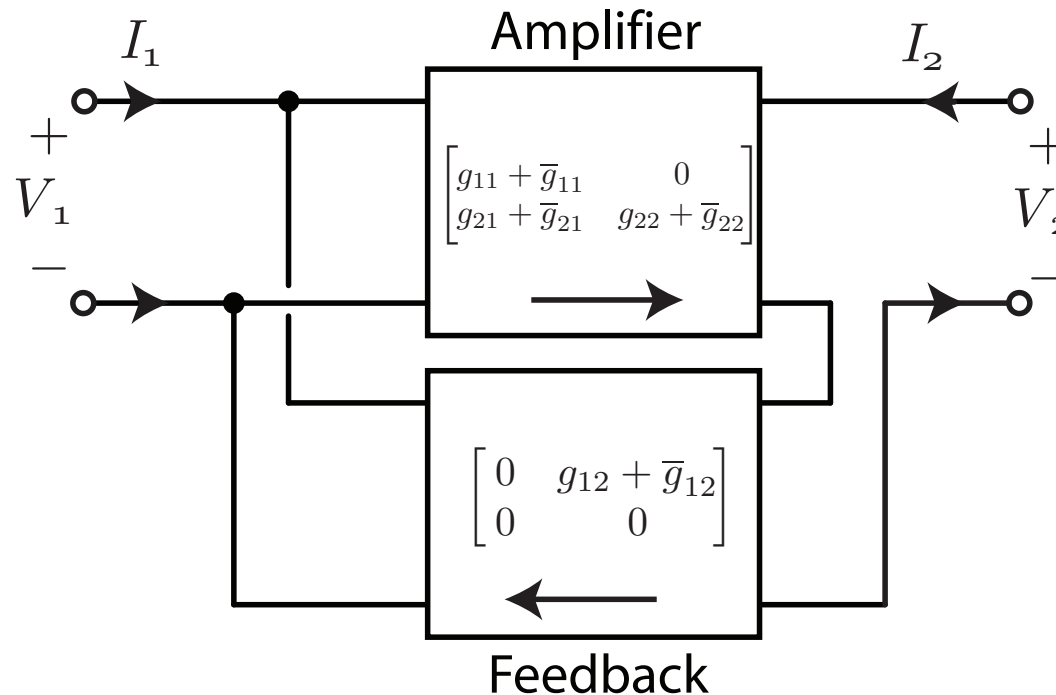

- Since the overall two-port parameters of the amplifier in closed loop is simply the *sum* of the amplifier and feedback network two-port parameters, we can simply move the non-idealities of the feedback network (loading and feedforward) into the main amplifier and likewise move the intrinsic feedback of the amplifier to the feedback network.
- Now we can use ideal feedback analysis.

# Y Parameters

- In this lecture we'll primarily use the  $Y$  parameters

$$\begin{pmatrix} i_1 \\ i_2 \end{pmatrix} = \begin{pmatrix} y_{11} & y_{12} \\ y_{21} & y_{22} \end{pmatrix} \begin{pmatrix} v_1 \\ v_2 \end{pmatrix}$$

- But our choice is arbitrary. We're lucky because many of the results that we derive in terms of  $Y$ -parameters can be applied to other two-port parameters exactly (input impedance, output impedance, gain, etc).
- Remember all 2-port parameters are different representations of the same two-port and therefore must yield the same answer for any question. It is relatively easy to convert between different two-port representations.

# Admittance Parameters

- Notice that  $y_{11}$  is the short circuit input admittance

$$y_{11} = \left. \frac{i_1}{v_1} \right|_{v_2=0}$$

- The same can be said of  $y_{22}$ . The forward transconductance is described by  $y_{21}$

$$y_{21} = \left. \frac{i_2}{v_1} \right|_{v_2=0}$$

- whereas the reverse transconductance is described by  $y_{12}$ .
- If a two-port amplifier is unilateral, then  $y_{12} = 0$

# Hybrid- $\Pi$ Admittance Parameters

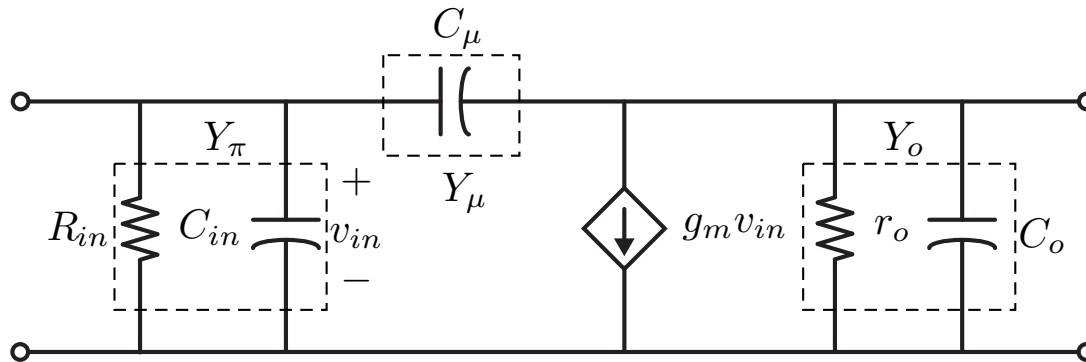

- Let's compute the  $Y$  parameters for the common hybrid- $\Pi$  model

$$y_{11} = y_{\pi} + y_{\mu}$$

$$y_{21} = g_m - y_{\mu}$$

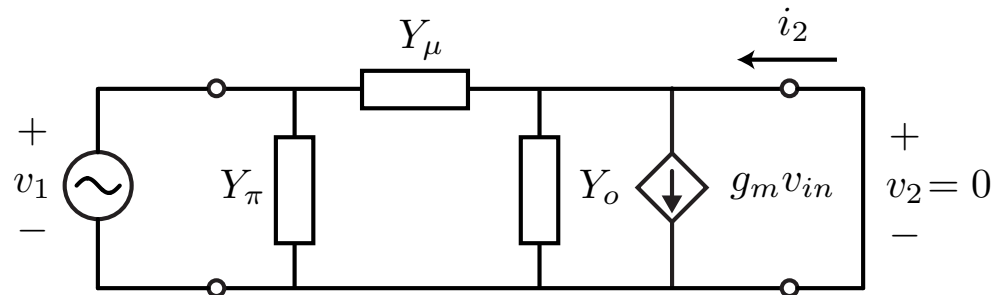

# Admittance Parameters (cont)

$$y_{22} = y_o + y_\mu$$

$$y_{12} = -y_\mu$$

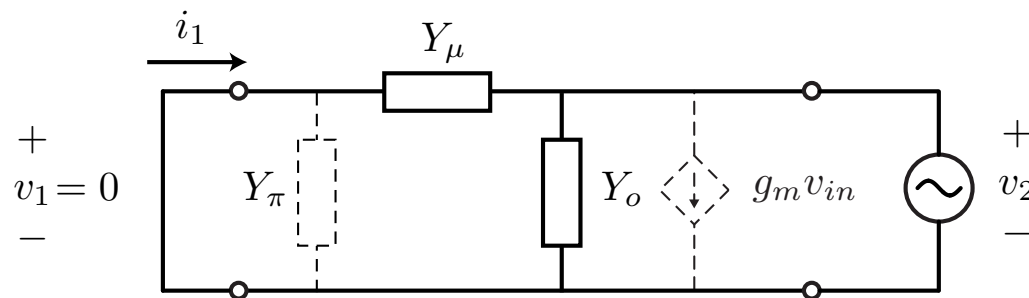

- Note that the hybrid- $\pi$  model is unilateral if  $y_\mu = sC_\mu = 0$ . Therefore it's unilateral at DC.
- A good amplifier has a high ratio  $\frac{y_{21}}{y_{12}}$  because we expect the forward transconductance to dominate the behavior

# Why Use Two-Port Parameters?

- The parameters are generic and independent of the details of the amplifier → can be a single transistor or a multi-stage amplifier
- High frequency transistors are more easily described by two-port parameters (due to distributed input gate resistance and induced channel resistance)
- Feedback amplifiers can often be decomposed into an equivalent two-port unilateral amplifier and a two-port feedback section
- We can make some very general conclusions about the “optimal” power gain of a two-port, allowing us to define some useful metrics

# Voltage Gain and Input Admittance

- Since  $i_2 = -v_2 Y_L$ , we can write

$$(y_{22} + Y_L)v_2 = -y_{21}v_1$$

- Which leads to the “internal” two-port gain

$$A_v = \frac{v_2}{v_1} = \frac{-y_{21}}{y_{22} + Y_L}$$

- Check low freq limit for a hybrid-II:  $A_v = -g_m Z_o || Z_L$  ✓
- The input admittance is easily calculated from the voltage gain

$$Y_{in} = \frac{i_1}{v_1} = y_{11} + y_{12} \frac{v_2}{v_1}$$

$$Y_{in} = y_{11} - \frac{y_{12}y_{21}}{y_{22} + Y_L}$$

# Output Admittance

- By symmetry we can write down the output admittance by inspection

$$Y_{out} = y_{22} - \frac{y_{12}y_{21}}{y_{11} + Y_S}$$

- Note that for a unilateral amplifier  $y_{12} = 0$  implies that

$$Y_{in} = y_{11}$$

$$Y_{out} = y_{22}$$

- The input and output impedance are de-coupled!

# External Voltage Gain

- The gain from the voltage source to the output can be derived by a simple voltage divider equation

$$A'_v = \frac{v_2}{v_s} = \frac{v_2}{v_1} \frac{v_1}{v_s} = A_v \frac{Y_S}{Y_{in} + Y_S} = \frac{-Y_S y_{21}}{(y_{22} + Y_L)(Y_S + Y_{in})}$$

- If we substitute and simplify the above equation we have

$$A'_v = \frac{-Y_S y_{21}}{(Y_S + y_{11})(Y_L + y_{22}) - y_{12} y_{21}}$$

- Verify that this makes sense at low frequency for hybrid-II:

$$A'_v(DC) = \frac{-Y_S y_{21}}{(Y_S + y_{11})(Y_L + y_{22})} = \frac{Z_{in}}{Z_{in} + Z_S} \times -g_m R_L || r_o$$

# Feedback Amplifiers and $Y$ -Params

- Note that in an ideal feedback system, the amplifier is unilateral and the closed loop gain is given by  $\frac{y}{x} = \frac{A}{1+Af}$
- We found last lecture that the voltage gain of a general two-port driven with source admittance  $Y_S$  is given by

$$A'_v = \frac{-Y_S y_{21}}{(Y_S + y_{11})(Y_L + y_{22}) - y_{12}y_{21}}$$

- If we unilaterize the two-port by arbitrarily setting  $y_{12} = 0$ , we have an “open” loop forward gain of

$$A_{vu} = A'_v|_{y_{12}=0} = \frac{-Y_S y_{21}}{(Y_S + y_{11})(Y_L + y_{22})}$$

# Identification of Loop Gain

- Re-writing the gain  $A'_v$  by dividing numerator and denominator by the factor  $(Y_S + y_{11})(Y_L + y_{22})$  we have

$$A'_v = \frac{\frac{-Y_S y_{21}}{(Y_S + y_{11})(Y_L + y_{22})}}{1 - \frac{y_{12} y_{21}}{(Y_S + y_{11})(Y_L + y_{22})}}$$

- We can now see that the “closed” loop gain with  $y_{12} \neq 0$  is given by

$$A'_v = \frac{A_{vu}}{1 + T}$$

- where  $T$  is identified as the loop gain

$$T = A_{vu} f = \frac{-y_{12} y_{21}}{(Y_S + y_{11})(Y_L + y_{22})}$$

# The Feedback Factor and Loop Gain

- Using the last equation also allows us to identify the feedback factor

$$f = \frac{Y_{12}}{Y_S}$$

- If we include the loading by the source  $Y_S$ , the input admittance of the amplifier is given by

$$Y_{in} = Y_S + y_{11} - \frac{y_{12}y_{21}}{Y_L + y_{22}}$$

- Note that this can be re-written as

$$Y_{in} = (Y_S + y_{11}) \left( 1 - \frac{y_{12}y_{21}}{(Y_S + y_{11})(Y_L + y_{22})} \right)$$

# Feedback and Input/Output Admittance

- The last equation can be re-written as

$$Y_{in} = (Y_S + y_{11})(1 + T)$$

- Since  $Y_S + y_{11}$  is the input admittance of a unilateral amplifier, we can interpret the action of the feedback as raising the input admittance by a factor of  $1 + T$ .
- Likewise, the same analysis yields

$$Y_{out} = (Y_L + y_{22})(1 + T)$$

- It's interesting to note that the same equations are valid for series feedback using  $Z$  parameters, in which case the action of the feedback is to boost the input and output impedance.

# Stability and Negative Resistance

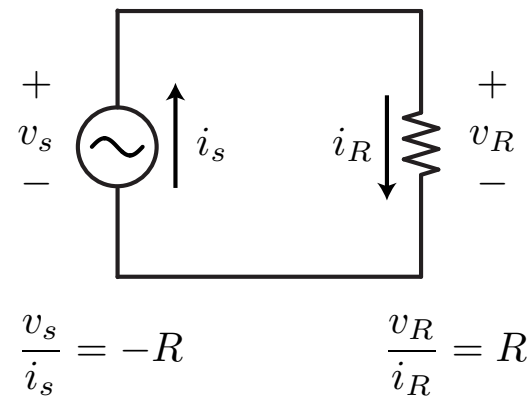
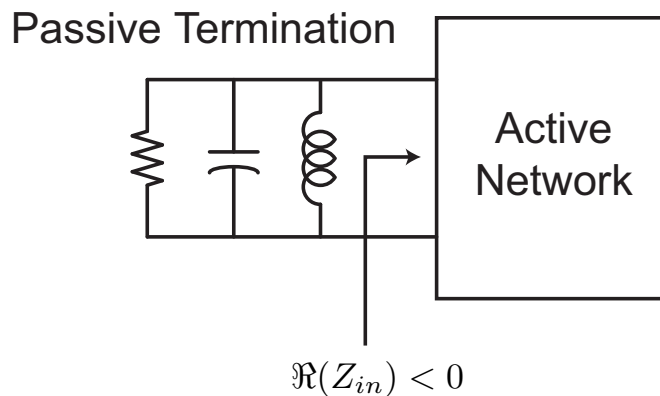

- Loosely speaking, a two-port network is stable if it does not oscillate. Oscillation occurs when the two-port can deliver power.
- The two-port sources power to the RLC termination shown above .
- Notice that when a voltage source is sources power to resistor  $R$ , the voltage to current ratio is negative

# More Rigorous Proof of Stability

- The two-port network is unstable if it supports non-zero currents/voltages with passive terminations

$$\begin{pmatrix} i_1 \\ i_2 \end{pmatrix} = \begin{pmatrix} y_{11} & y_{12} \\ y_{21} & y_{22} \end{pmatrix} \begin{pmatrix} v_1 \\ v_2 \end{pmatrix}$$

- Since  $i_1 = -v_1 Y_S$  and  $i_2 = -v_2 Y_L$

$$\begin{pmatrix} y_{11} + Y_S & y_{12} \\ y_{21} & y_{22} + Y_L \end{pmatrix} \begin{pmatrix} v_1 \\ v_2 \end{pmatrix} = 0$$

- The only way to have a non-trivial solution is for the determinant of the matrix to be zero at a particular frequency

# Conditions for Instability: Loop Gain

- Taking the determinant of the matrix we have

$$(Y_S + y_{11})(Y_L + y_{22}) - y_{12}y_{21} = 0$$

- Let's re-write the above in the following form

$$1 - \frac{y_{12}y_{21}}{(y_{22} + Y_L)(y_{11} + Y_S)} = 0$$

or

$$1 + T = 0$$

- Where we have identified the loop gain  $T$ . We can clearly see that instability implies that  $T = -1$ , which is exactly what we learned in feedback system analysis.

# Conditions for Instability: Impedance

- Going back to the determinant of the matrix we have

$$(Y_S + y_{11})(Y_L + y_{22}) - y_{12}y_{21} = 0$$

- Now let's re-write the above in the following form

$$Y_S + y_{11} - \frac{y_{12}y_{21}}{y_{22} + Y_L} = 0$$

or

$$Y_S + Y_{in} = 0$$

- Or equivalently

$$Y_L + Y_{out} = 0$$

# Stability (cont)

- A network is unstable at a particular frequency if  $Y_S + Y_{in} = 0$ , which means the condition is satisfied for both the real and imaginary part. In particular

$$\Re(Y_S + Y_{in}) = \Re(Y_S) + \Re(Y_{in}) = 0$$

- Since the terminations are passive,  $\Re(Y_S) > 0$  which implies that

$$\Re(Y_{in}) < 0$$

- The same equations also show that

$$\Re(Y_{out}) < 0$$

- So if these conditions are satisfied, the two-port is unstable

# More on Stability

- The conditions for stability are a function of the source and load termination

$$\Re(Y_{in}) = \Re\left(y_{11} - \frac{y_{12}y_{21}}{Y_L + y_{22}}\right) > 0$$

$$\Re(Y_{out}) = \Re\left(y_{22} - \frac{y_{12}y_{21}}{Y_S + y_{11}}\right) > 0$$

- For a unilateral amplifier, the conditions are simple and only depend on the two-port

$$\Re(y_{11}) > 0$$

$$\Re(y_{22}) > 0$$

# Stability Factor

- In general, it can be shown that a two-port is absolutely stable iff

$$\Re(y_{11}) > 0$$

$$\Re(y_{22}) > 0$$

$$k > 1$$

- The stability factor  $k$  is given by

$$k = \frac{2\Re(y_{11})\Re(y_{22}) - \Re(y_{12}y_{21})}{|y_{12}y_{21}|}$$

- The stability of a unilateral amplifier with  $y_{12} = 0$  is infinite  $k = \infty$  which implies absolute stability since as long as  $\Re(y_{11}) > 0$  and  $\Re(y_{22}) > 0$

# Degrees of Stability

- A amplifier with absolute stability or *unconditional stability* ( $k > 1$ ) means that the two-port is stable for all passive terminations at either the load or the source.
- If  $k < 1$ , then the system can be *conditionally stable*, or stable for a range of source/load impedances. This range of impedance is very easily calculated using scattering parameters. It's also possible for a system to be completely unstable.
- Unconditional stability is very conservative if the source and load impedance is well specified and well controlled.
- But in certain situations the load or source impedance may vary greatly. For instance the input impedance of an antenna can vary if the antenna is disconnected, bent, shorted, or broken.
- An unstable two-port can be stabilized by adding sufficient loss at the input or output to overcome the negative conductance.