

Lecture 22: Sinusoidal Oscillators

Prof. Ali M. Niknejad

University of California, Berkeley

Copyright © 2008 by Ali M. Niknejad

Oscillators

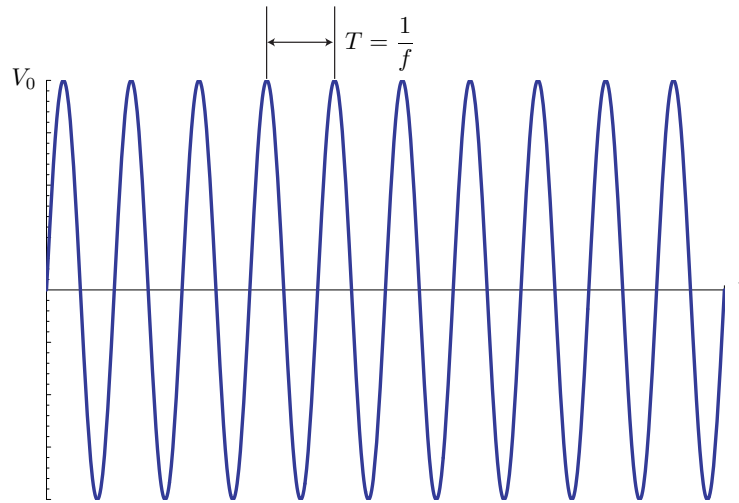

- An oscillator is an *autonomous* circuit that converts DC power into a periodic waveform. We will initially restrict our attention to a class of oscillators that generate a sinusoidal waveform.
- The period of oscillation is determined by a high-Q LC tank or a resonator (crystal, cavity, T-line, etc.). An oscillator is characterized by its oscillation amplitude (or power), frequency, “stability”, phase noise, and tuning range.

Oscillators (cont)

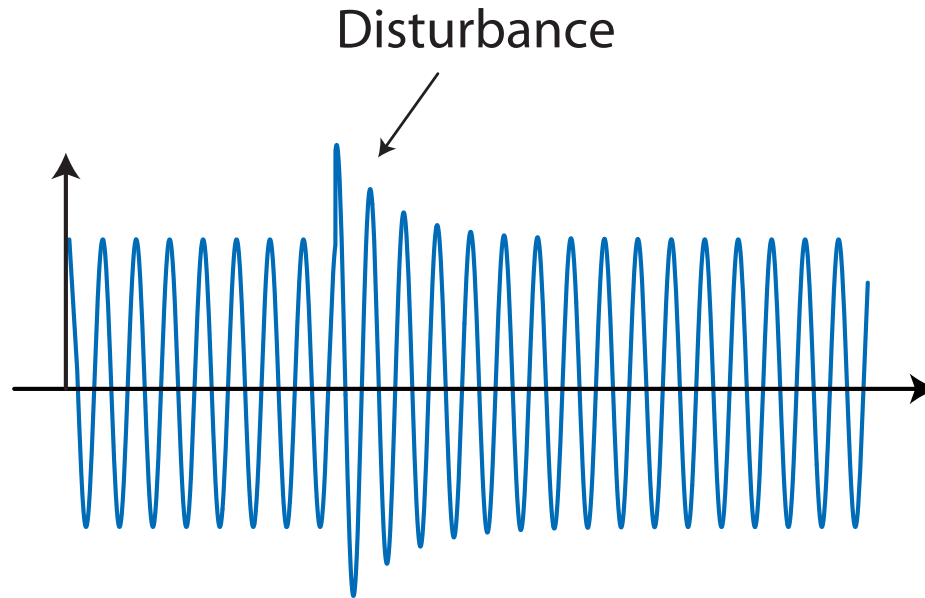

- Generically, a good oscillator is stable in that its frequency and amplitude of oscillation do not vary appreciably with temperature, process, power supply, and external disturbances.
- The amplitude of oscillation is particularly stable, always returning to the same value (even after a disturbance).

Phase Noise

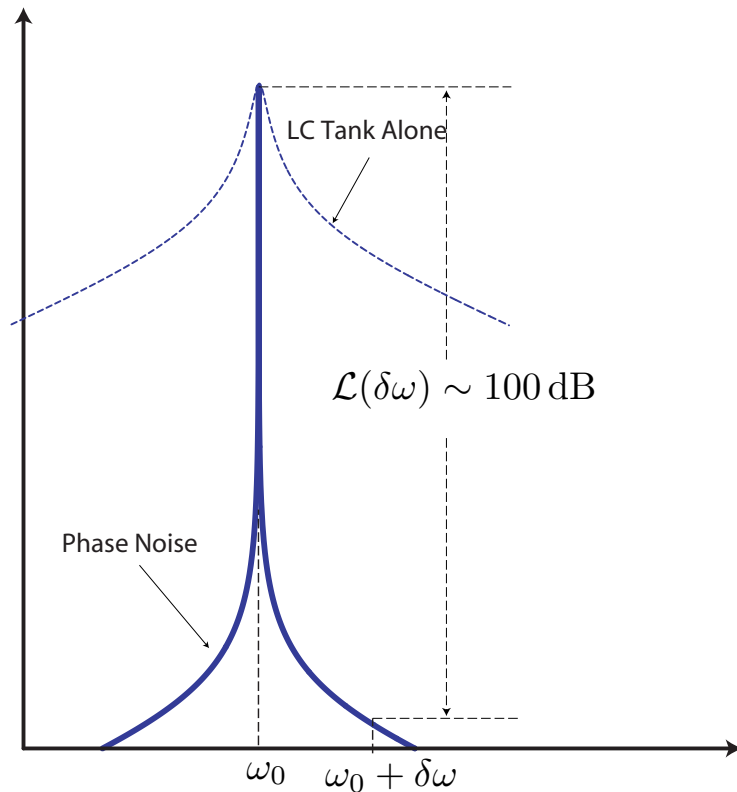

- Due to noise, a real oscillator does not have a delta-function power spectrum, but rather a very sharp peak at the oscillation frequency.
- The amplitude drops very quickly, though, as one moves away from the center frequency. E.g. a cell phone oscillator has a phase noise that is 100 dB down at an offset of only 0.01% from the carrier!

An LC Tank “Oscillator”

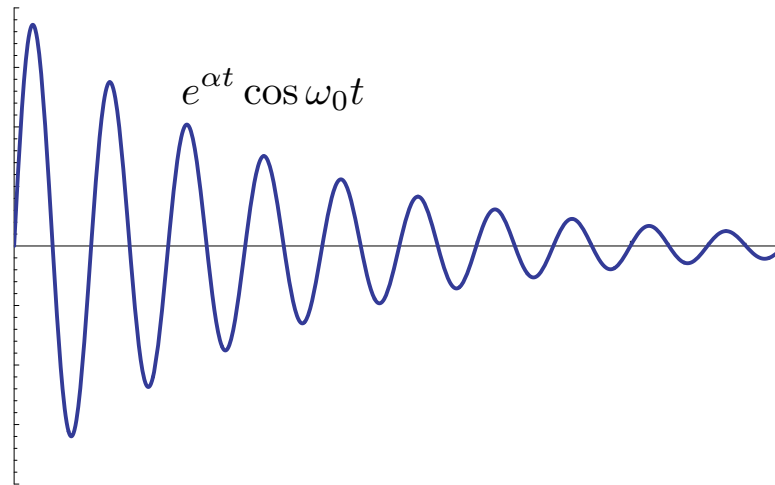

- Note that an LC tank alone is not a good oscillator. Due to loss, no matter how small, the amplitude of the oscillator decays.
- Even a very high Q oscillator can only sustain oscillations for about Q cycles. For instance, an LC tank at 1GHz has a $Q \sim 20$, can only sustain oscillations for about 20ns.
- Even a resonator with high $Q \sim 10^6$, will only sustain oscillations for about 1ms.

Feedback Perspective

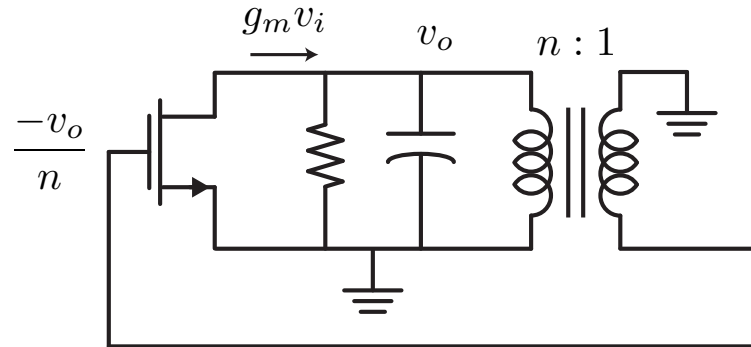

- Many oscillators can be viewed as feedback systems. The oscillation is sustained by feeding back a fraction of the output signal, using an amplifier to gain the signal, and then injecting the energy back into the tank. The transistor “pushes” the LC tank with just about enough energy to compensate for the loss.

Negative Resistance Perspective

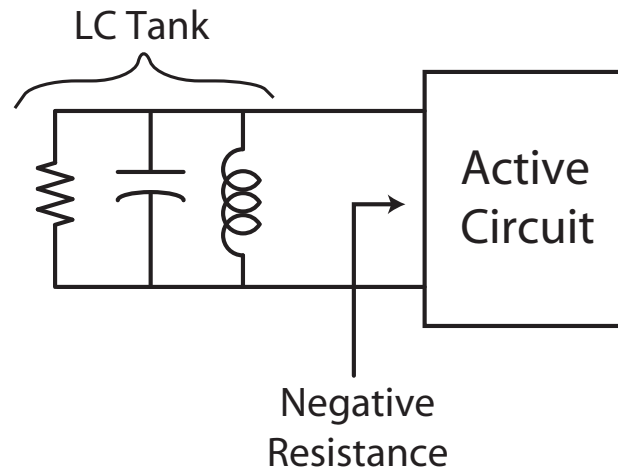

- Another perspective is to view the active device as a negative resistance generator. In steady state, the losses in the tank due to conductance G are balanced by the power drawn from the active device through the negative conductance $-G$.

Feedback Approach

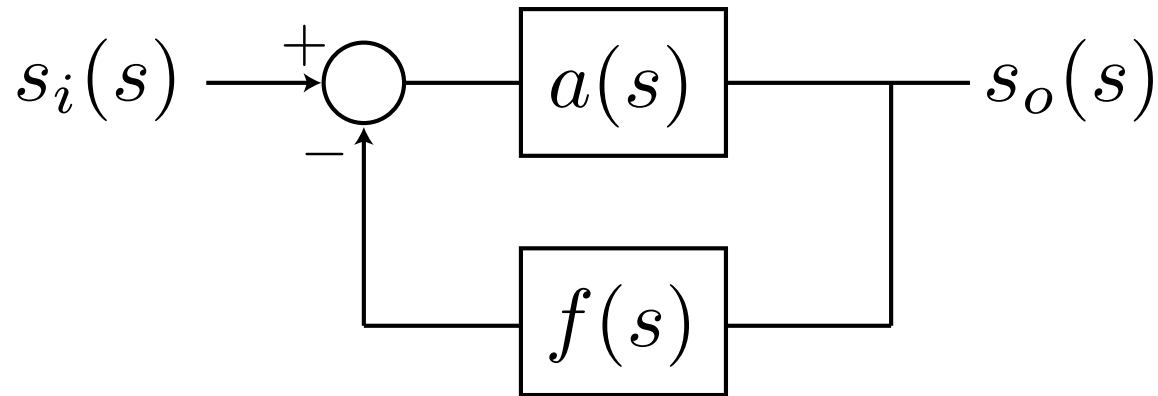

- Consider an ideal feedback system with forward gain $a(s)$ and feedback factor $f(s)$. The closed-loop transfer function is given by

$$H(s) = \frac{a(s)}{1 + a(s)f(s)}$$

Feedback Example

- As an example, consider a forward gain transfer function with three identical real negative poles with magnitude $|\omega_p| = 1/\tau$ and a frequency independent feedback factor f

$$a(s) = \frac{a_0}{(1 + s\tau)^3}$$

- Deriving the closed-loop gain, we have

$$H(s) = \frac{a_0}{(+s\tau)^3 + a_0 f} = \frac{K_1}{(1 - s/s_1)(1 - s/s_2)(1 - s/s_3)}$$

- where $s_{1,2,3}$ are the poles of the feedback amplifier.

Poles of Closed-Loop Gain

- Solving for the poles

$$(1 + s\tau)^3 = -a_0 f$$

$$1 + s\tau = (-a_0 f)^{\frac{1}{3}} = (a_0 f)^{\frac{1}{3}} (-1)^{\frac{1}{3}}$$

$$(-1)^{\frac{1}{3}} = -1, e^{j60^\circ}, e^{-j60^\circ}$$

- The poles are therefore

$$s_1, s_2, s_3 = \frac{-1 - (a_0 f)^{\frac{1}{3}}}{\tau}, \frac{-1 + (a_0 f)^{\frac{1}{3}} e^{\pm j60^\circ}}{\tau}$$

Root Locus

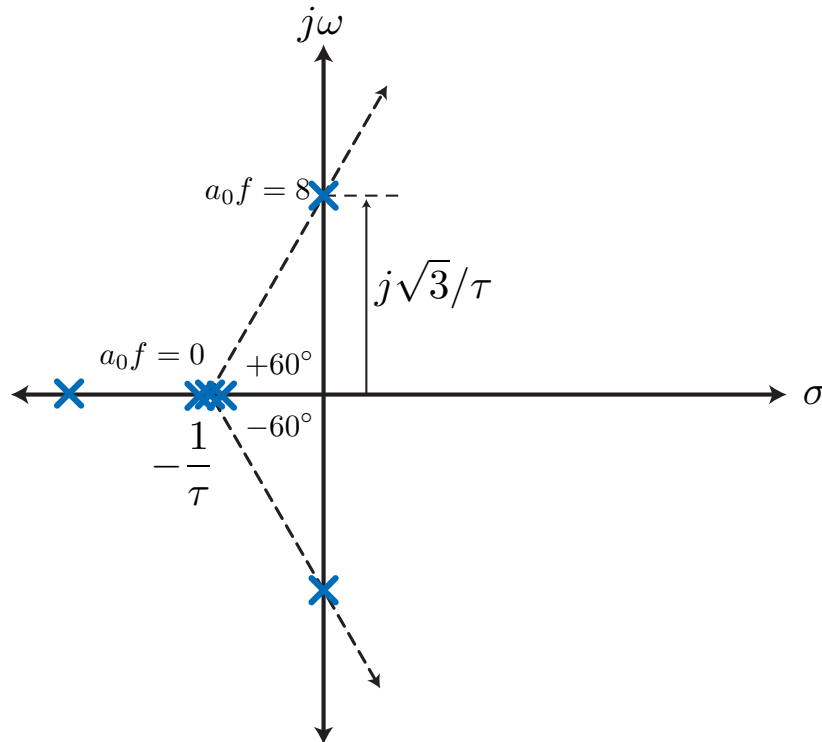

- If we plot the poles on the s-plane as a function of the DC loop gain $T_0 = a_0f$ we generate a *root locus*
- For $a_0f = 8$, the poles are on the $j\omega$ -axis with value

$$s_1 = -3/\tau$$

$$s_{2,3} = \pm j\sqrt{3}/\tau$$

- For $a_0f > 8$, the poles move into the right-half plane (RHP)

Natural Response

- Given a transfer function

$$H(s) = \frac{K}{(s - s_1)(s - s_2)(s - s_3)} = \frac{a_1}{s - s_1} + \frac{a_2}{s - s_2} + \frac{a_3}{s - s_3}$$

- The total response of the system can be partitioned into the *natural response* and the forced response

$$s_0(t) = f_1(a_1 e^{s_1 t} + a_2 e^{s_2 t} + a_3 e^{s_3 t}) + f_2(s_i(t))$$

- where $f_2(s_i(t))$ is the forced response whereas the first term $f_1()$ is the natural response of the system, even in the absence of the input signal. The natural response is determined by the initial conditions of the system.

Real LHP Poles

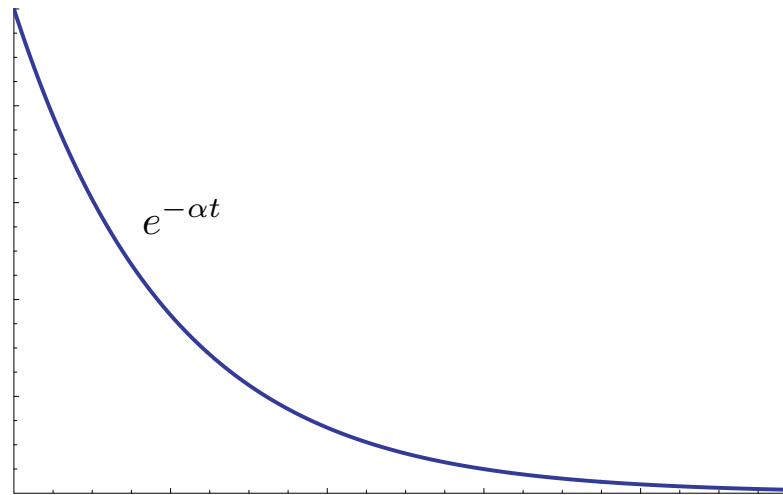

- Stable systems have all poles in the left-half plane (LHP).
- Consider the natural response when the pole is on the negative real axis, such as s_1 for our examples.
- The response is a decaying exponential that dies away with a time-constant determined by the pole magnitude.

Complex Conjugate LHP Poles

- Since $s_{2,3}$ are a complex conjugate pair

$$s_2, s_3 = \sigma \pm j\omega_0$$

- We can group these responses since $a_3 = \overline{a_2}$ into a single term

$$a_2 e^{s_2 t} + a_3 e^{s_3 t} = K_a e^{\sigma t} \cos \omega_0 t$$

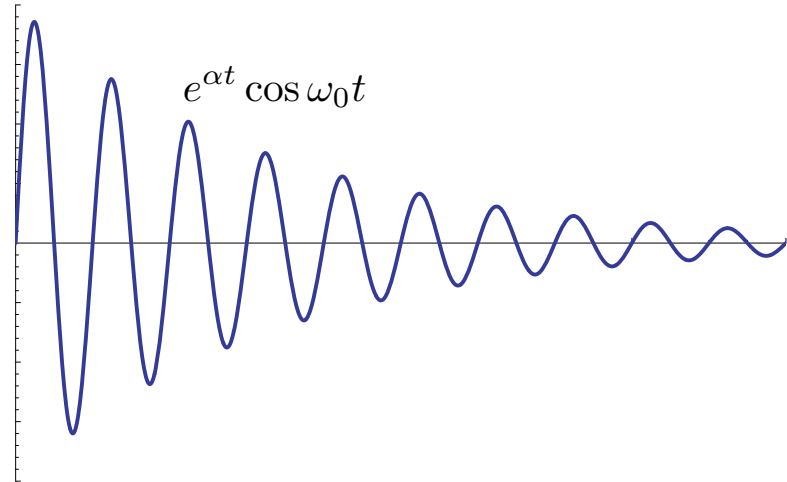

- When the real part of the complex conjugate pair σ is negative, the response also decays exponentially.

Complex Conjugate Poles (RHP)

- When σ is positive (RHP), the response is an exponential growing oscillation at a frequency determined by the imaginary part ω_0
- Thus we see for any amplifier with three identical poles, if feedback is applied with loop gain $T_0 = a_0 f > 8$, the amplifier will oscillate.

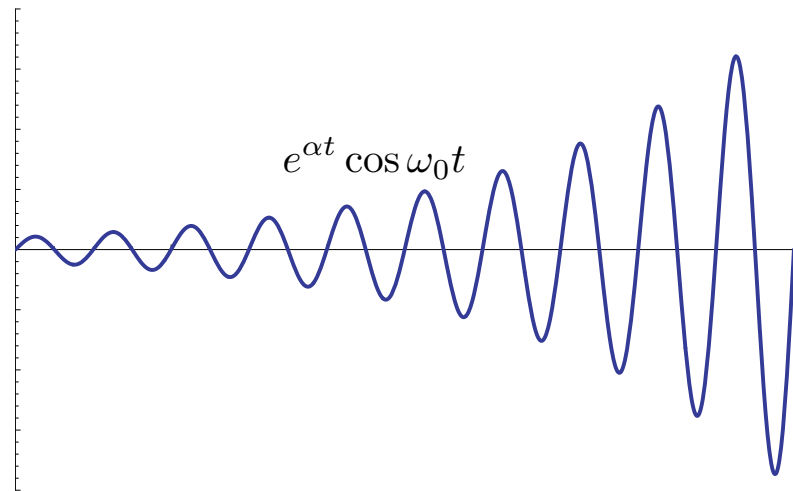

Frequency Domain Perspective

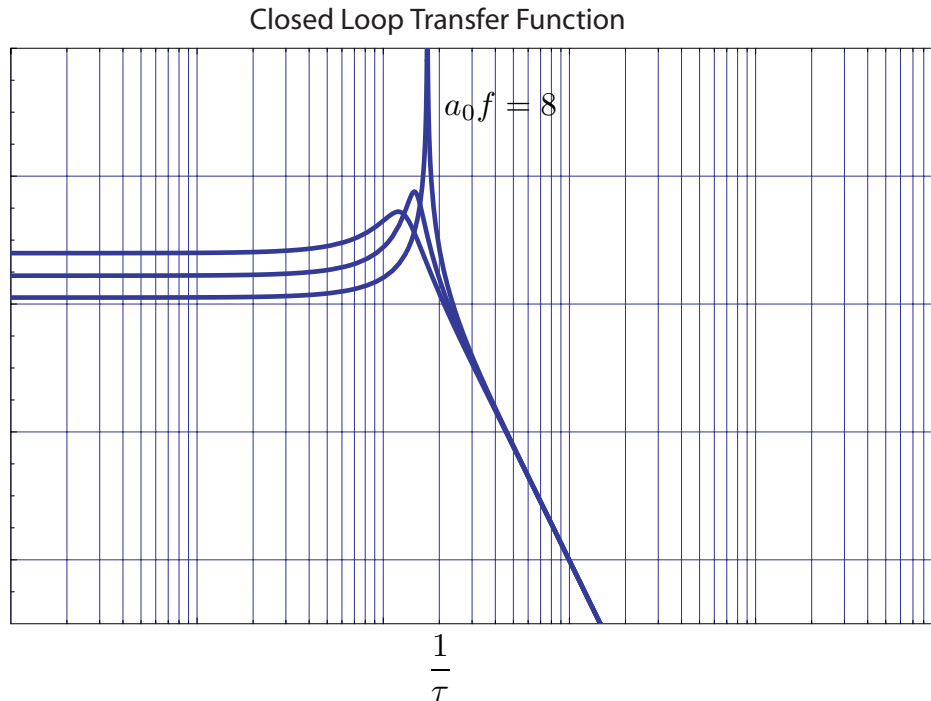

- In the frequency domain perspective, we see that a feedback amplifier has a transfer function

$$H(j\omega) = \frac{a(j\omega)}{1 + a(j\omega)f}$$

- If the loop gain $a_0 f = 8$, then we have with purely imaginary poles at a frequency $\omega_x = \sqrt{3}/\tau$ where the transfer function $a(j\omega_x)f = -1$ blows up. Apparently, the feedback amplifier has infinite gain at this frequency.

Oscillation Build Up

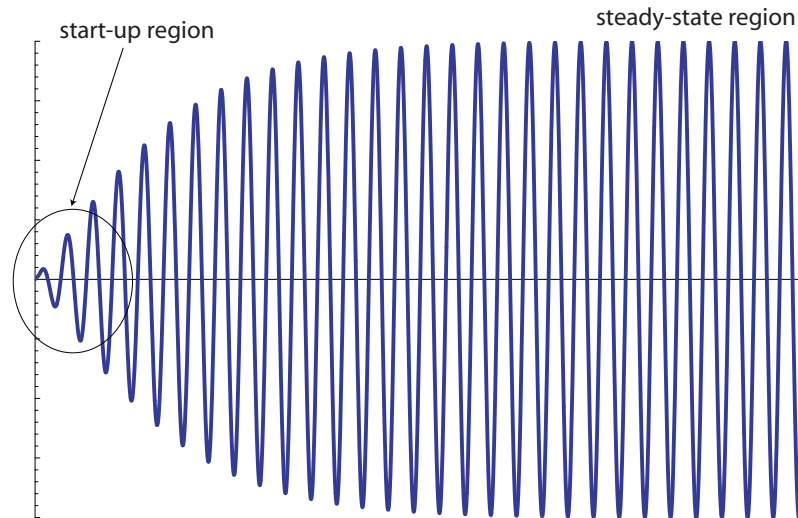

- In a real oscillator, the amplitude of oscillation initially grows exponentially as our linear system theory predicts. This is expected since the oscillator amplitude is initially very small and such theory is applicable. But as the oscillations become more vigorous, the non-linearity of the system comes into play.
- We will analyze the steady-state behavior, where the system is non-linear but periodically time-varying.

Example LC Oscillator

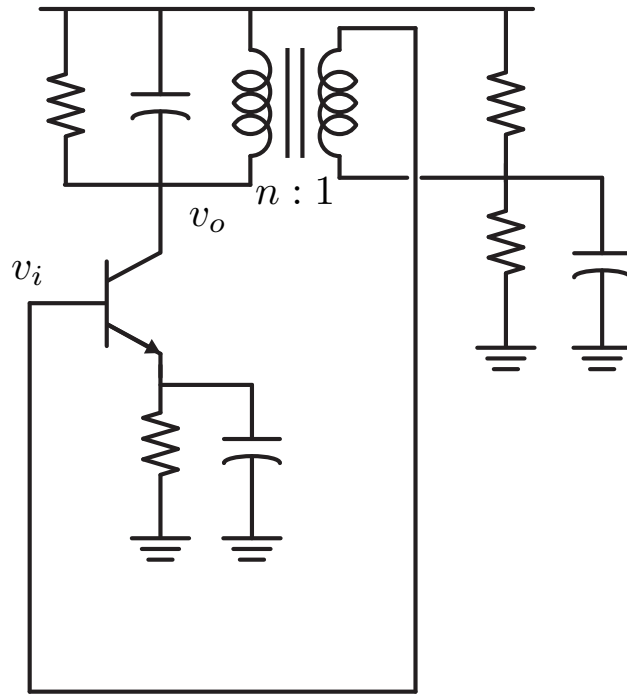

- The emitter resistor is bypassed by a large capacitor at AC frequencies.
 - The base of the transistor is conveniently biased through the transformer windings.
-
- The LC oscillator uses a transformer for feedback. Since the amplifier has a phase shift of 180° , the feedback transformer needs to provide an additional phase shift of 180° to provide positive feedback.

AC Equivalent Circuit

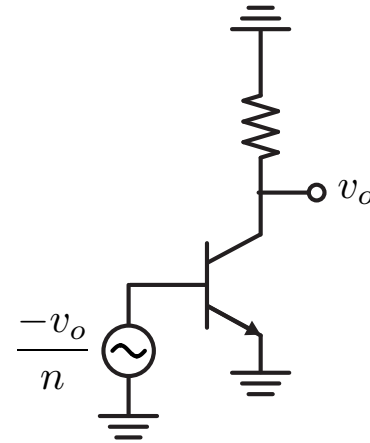
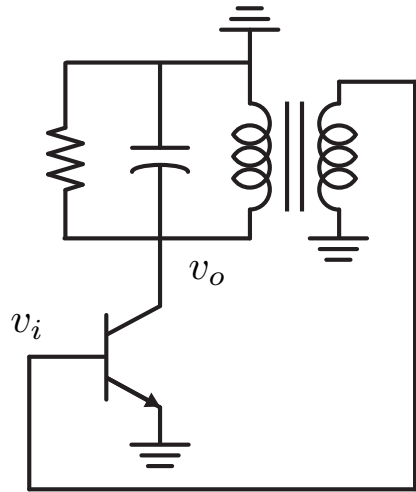

- At resonance, the AC equivalent circuit can be simplified. The transformer winding inductance L resonates with the total capacitance in the circuit. R_T is the equivalent tank impedance at resonance.

Small Signal Equivalent Circuit

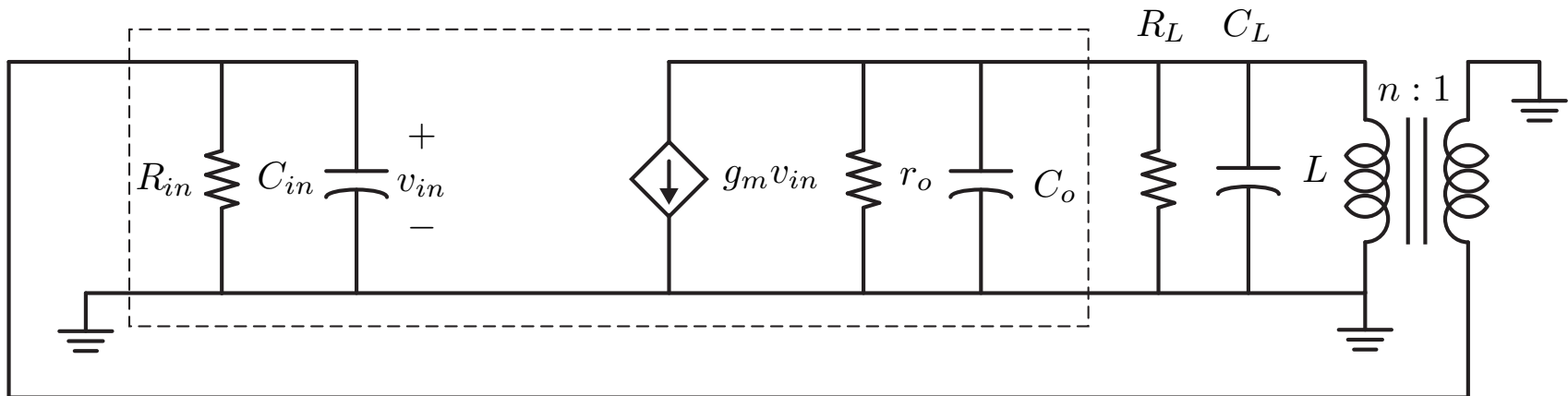

- The forward gain is given by $a(s) = -g_m Z_T(s)$, where the tank impedance Z_T includes the loading effects from the input of the transistor

$$R = R_o || R_L || n^2 R_i$$

$$C = C_L + \frac{C_i}{n^2}$$

Open-Loop Transfer Function

- The tank impedance is therefore

$$Z_T(s) = \frac{1}{sC + \frac{1}{R} + \frac{1}{Ls}} = \frac{Ls}{1 + s^2LC + sL/R}$$

- The loop gain is given by

$$af(s) = \frac{-g_m R}{n} \frac{\frac{L}{R}s}{1 + \frac{L}{R}s + s^2LC}$$

- The loop gain at resonance is the same as the DC loop gain

$$A_\ell = \frac{-g_m R}{n}$$

Closed-Loop Transfer Function

- The closed-loop transfer function is given by

$$H(s) = \frac{-g_m R \frac{L}{R} s}{1 + s^2 LC + s \frac{L}{R} \left(1 - \frac{g_m R}{n}\right)}$$

- Where the denominator can be written as a function of A_ℓ

$$H(s) = \frac{-g_m R \frac{L}{R} s}{1 + s^2 LC + s \frac{L}{R} (1 - A_\ell)}$$

- Note that as $n \rightarrow \infty$, the feedback loop is broken and we have a tuned amplifier. The pole locations are determined by the tank Q .

Oscillator Closed-Loop Gain vs A_ℓ

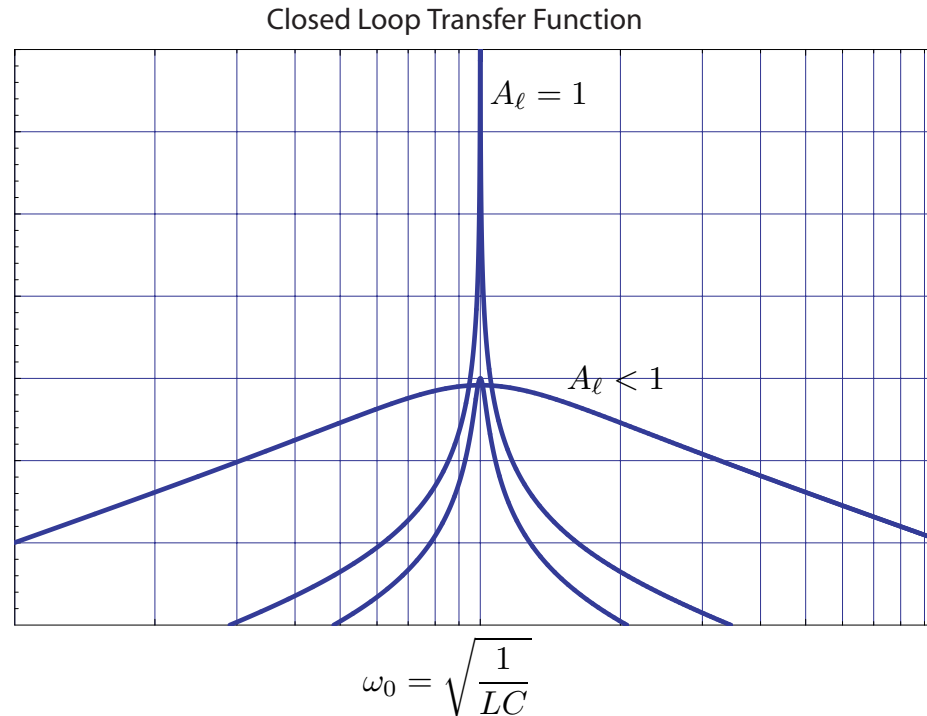

- If $A_\ell = 1$, then the denominator loss term cancels out and we have two complex conjugate imaginary axis poles

$$1 + s^2 LC = (1 + sj\sqrt{LC})(1 - sj\sqrt{LC})$$

Root Locus for LC Oscillator

- For a second order transfer function, notice that the magnitude of the poles is constant, so they lie on a circle in the s-plane

$$s_{1,2} = \frac{-a}{2b} \pm \frac{a}{2b} \sqrt{1 - \frac{4b}{a^2}} = \frac{-a}{2b} \pm j \frac{a}{2b} \sqrt{\frac{4b}{a^2} - 1}$$

$$|s_{1,2}| = \sqrt{\frac{a^2}{4b^2} + \frac{a^2}{4b^2} \left(\frac{4b}{a^2} + 1 \right)} = \sqrt{\frac{1}{b}} = \omega_0$$

Root Locus (cont)

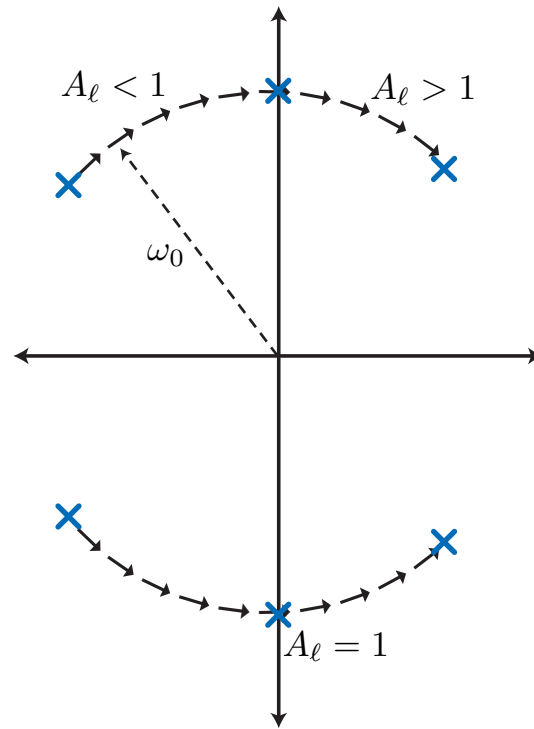

- We see that for $A_\ell = 0$, the poles are determined by the tank Q and lie in the LHP. As A_ℓ is increased, the action of the positive feedback is to boost the gain of the amplifier and to decrease the bandwidth. Eventually, as $A_\ell = 1$, the loop gain becomes infinite in magnitude.