

## *Lecture 21: Balanced and Passive Mixers*

Prof. Ali M. Niknejad

University of California, Berkeley

Copyright © 2008 by Ali M. Niknejad

# Double Balanced Mixer

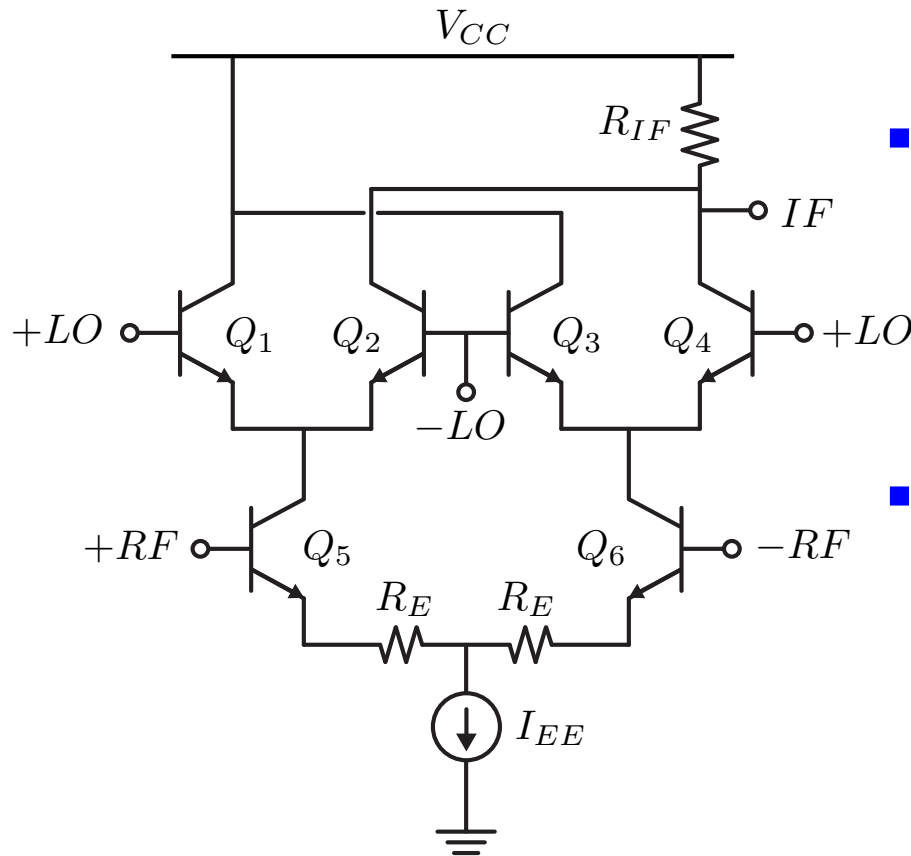

- The single balanced Gilbert cell with differential output rejects the RF at the IF port but the LO feed-through remains.
- A double balanced mixer has a differential RF and a differential LO (double *balanced*)

# Double Balanced Mixer LO Rejection

- As before, the RF stage is a transconductance stage. Degeneration can be used to linearize this stage.
- Because the bias current at the output is constant  $I_{EE}/2$  regardless of the LO voltage, the LO signal is rejected. This relies on good matching between transistor Q2 and Q4.
- The differential operation also rejects even order distortion. Viewed as two parallel Gilbert cells, this mixer is also more linear as it processes only half of the signal.
- The noise of this mixer, though, is higher since the noise in each transistor is independent.

# Mixer Operation

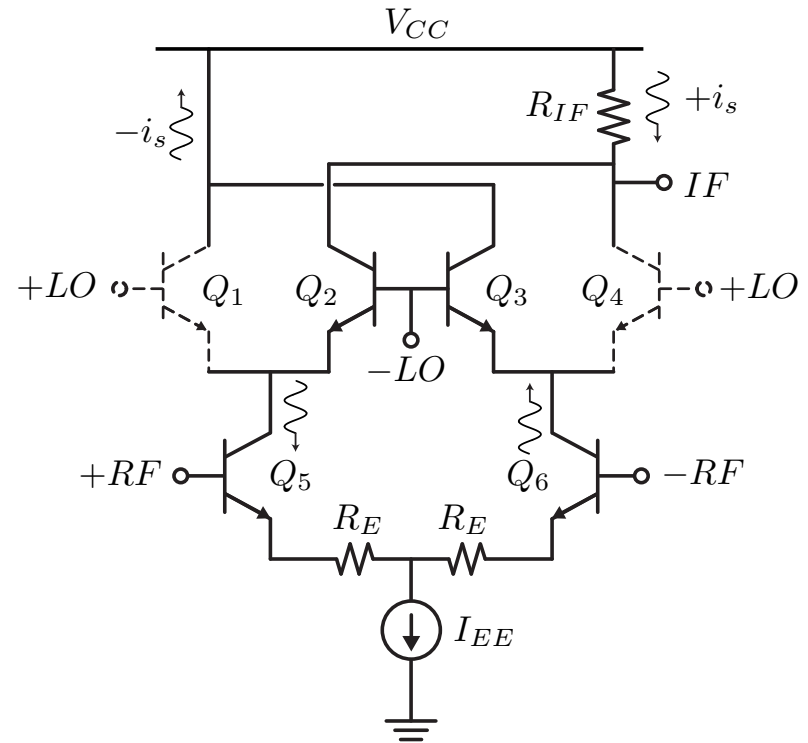
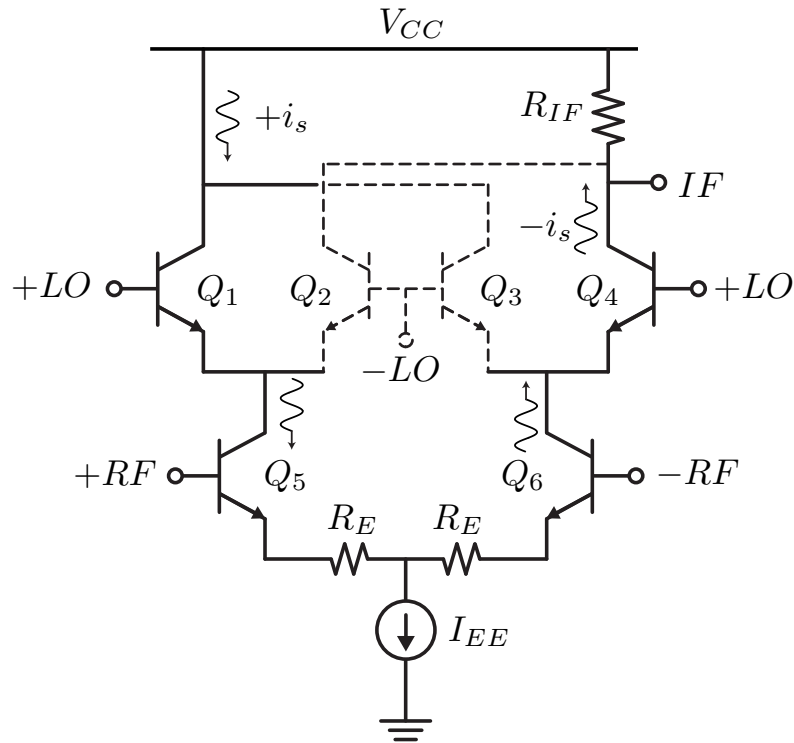

- The AC operation nearly identical to a single balanced Gilbert cell.
- Even a single ended output, though, effectively multiplies the signal by  $\pm 1$ , thus rejecting the RF signal.

# Mixer Noise Definition

- By definition we have  $F = \frac{SNR_i}{SNR_o}$ . If we apply this to a receiving mixer, the input signal is at the “RF” and the output signal is at “IF”. There is some ambiguity to this definition because we have to specify if the RF signal is a single or double sideband modulated waveform.
- For a double sideband modulated waveform, there is signal energy in both sidebands and so for a perfect multiplying mixer, the  $F = 1$  since the IF signal is twice as large since energy from both sidebands fall onto the IF. For a single-sideband modulated waveform, though, the noise from the image band adds doubling the IF noise relative to RF. Thus the  $F = 2$ .
- If an image reject filter is used, the noise in the image band can be suppressed and thus  $F = 1$  for a cascade of a sharp image reject filter followed by a multiplier.

# Mixer Noise Folding

- Since the mixer will downconvert any energy at a distance of  $IF$  from the LO and its harmonics, all the noise from these image bands will be downconverted to the same IF.
- For a Gilbert cell type mixer, the current of the  $G_m$  stage produces white noise which is downconverted. Summing over all the harmonics, we have

$$\sum_{k=-\infty}^{\infty} |c_k|^2 = \frac{1}{T} \int_0^T s(t)^2 dt$$

- where the last equality follows from Parseval's Theorem.
- For a square waveform  $s(t)$ , the harmonic powers fall like  $1/k^2$ . Thus the third harmonic contributes about 10% to the switching pair noise.

# Mixer Noise Due to Switching Pair

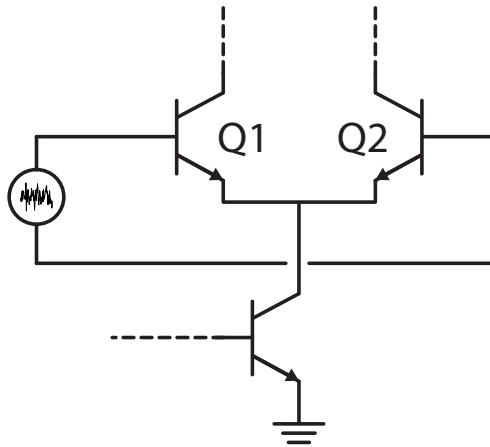

- In addition to the noise folding discussed above, the switching pair itself will contribute noise at IF. If Q1/Q2 are both on, they act as a differential amplifier and introduce noise.
- When only Q1 or Q2 is on, though, the noise is rejected due to the degeneration provided by the transconductance device.
- Thus we generally use a large LO signal to minimize the time when both devices are conducting. It's therefore not surprising that the noise figure of the mixer improves with increasing LO amplitude.

# Simulating Mixers with SPICE

- Let's take a typical example of  $RF = 1\text{GHz}$ ,  $IF = 1\text{MHz}$ . This requires an  $LO = RF \pm IF$ , close to the RF.
- To resolve the IF frequency components, we need to simulate several cycles of the IF, say 10, so  $T_{sim} = 10T_{IF}$
- But that means that we must simulate 10,000 RF cycles

$$\frac{T_{sim}}{T_{RF}} = \frac{10T_{IF}}{T_{RF}} = \frac{10f_{RF}}{f_{IF}} = \frac{10 \cdot 1000}{1} = 10,000$$

- If we are conservative, we may insist that we simulate at least 10 points of the RF cycle, that implies 100,000 points per simulation.
- This is a long and memory intensive simulation. We encountered a similar problem when simulating  $IM_3$

# Periodic Steady-State (PSS) Simulation

- Transient simulation is slow and costly because we have to do a tight tolerance simulation of several IF cycles with a weak RF.
- The SpectreRF PSS analysis is a tool for finding the periodic steady-state solution to a circuit. In essence, it tries to find the initial condition or state for the circuit (capacitor voltages, inductor currents) such that the circuit is in periodic steady state.
- It can usually find the periodic solution within 4-5 iterations.
- In the mixer, if we ignore the RF signal, then the periodic operating point is determined by the LO signal alone.

# PSS Iteration

- Since typical PSS run converges in 4-5 cycles of the LO, or a simulation time of about  $5T_{LO}$ , the overall simulation converges several orders of magnitude faster than transient at the IF frequency.
- PSS requires that the circuit is not chaotic (periodic input leads to a periodic output).
- High Q circuits do not pose a problem to PSS simulation since we are finding the steady-state solution. The high Q natural response takes roughly  $Q$  cycles to die down, thus saving much simulation time.

# PSS Options

- We can perform PSS analysis on *driven* or *autonomous* circuits. An autonomous circuit has no periodic inputs but produces a periodic output (e.g. an oscillator).
- For PSS analysis we need to specify a list of “large” signals in the circuit. In a mixer, the only large tone is the LO, so there is only one signal to list.
- We also specify the “beat frequency” or the frequency of the resulting periodic operating point. For instance if we drive a circuit with two large tones at  $f_1$  and  $f_2$ , the beat frequency is  $|f_1 - f_2|$ . Spectre can auto-calculate this frequency.
- An additional time for stabilization  $t_{stab}$  can be specified to help with the convergence. For a mixer this is not needed.

# Periodic AC (PAC)

- Once a PSS analysis is performed at the “beat frequency”, the circuit can be linearized about this time varying operating point.
- Note that for a given AC input, there are as many transfer functions as there are harmonics in the LO.
- We specify the frequency range of the AC input signal as either an absolute or relative range. A relative range is a frequency offset with respect to the beat frequency.
- We also specify the maximum sidebands to keep for the simulation. Note that this does not affect the accuracy of the simulation but simply the amount of saved data.

# PAC Picture

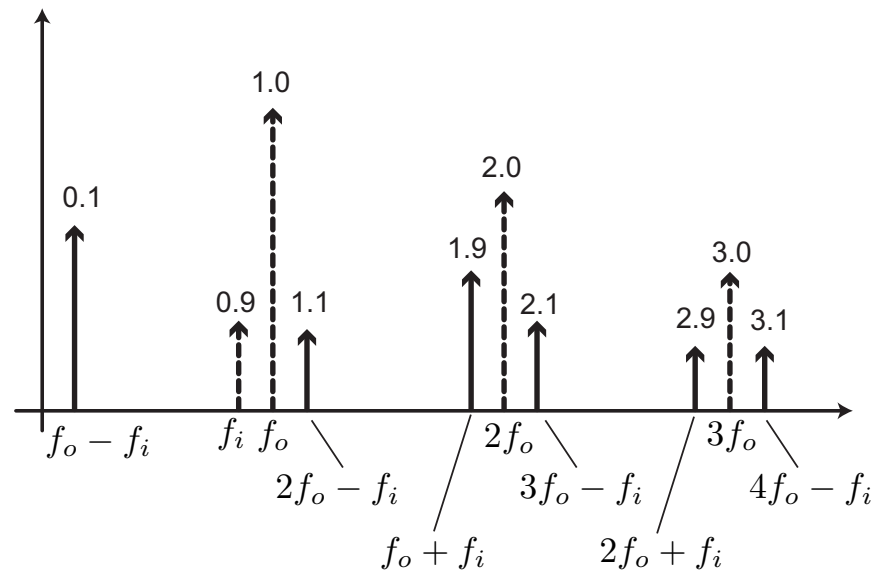

- The input frequency  $f_i$  is translated to frequencies  $f_i + kf_o$ , where  $f_o$  is the beat (LO) frequency. The  $k = 0$  sideband corresponds to the DC component of the LO signal (e.g. time invariant behavior). The non-zero components, though, correspond to mixing. E.g.  $k = -1$  correspond to frequency down-conversion.  $k = +1$  is the normal up-conversion.  $k = -2$  is the 2nd harmonic mixing  $f_i - 2f_o$ .

# PNoise

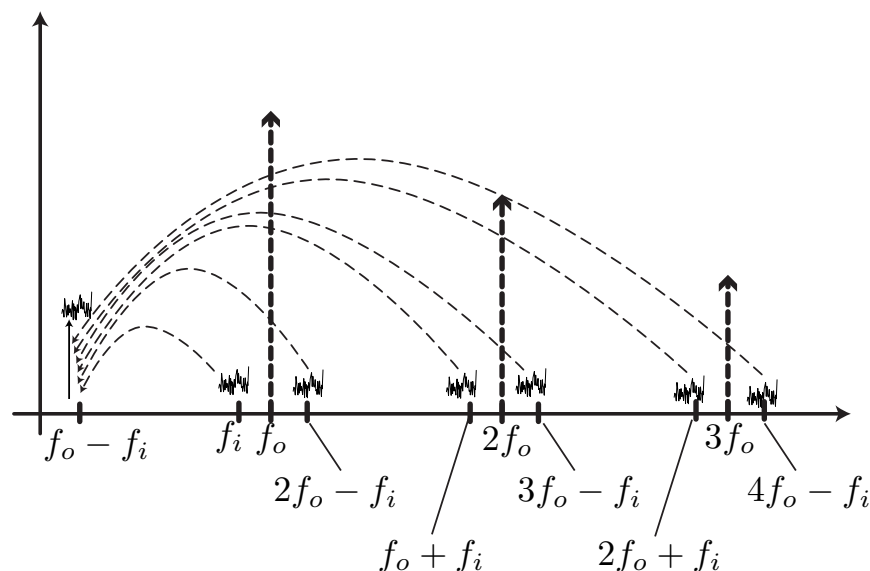

- PNoise is a noise analysis that takes the frequency translation effects into account. The simulation parameters are similar to PAC with the exception that we must identify the input and output ports (for noise figure) and the reference side-band, or the desired output frequency. For a mixer, this is  $k = -1$ .

# Voltage Switching Mixers

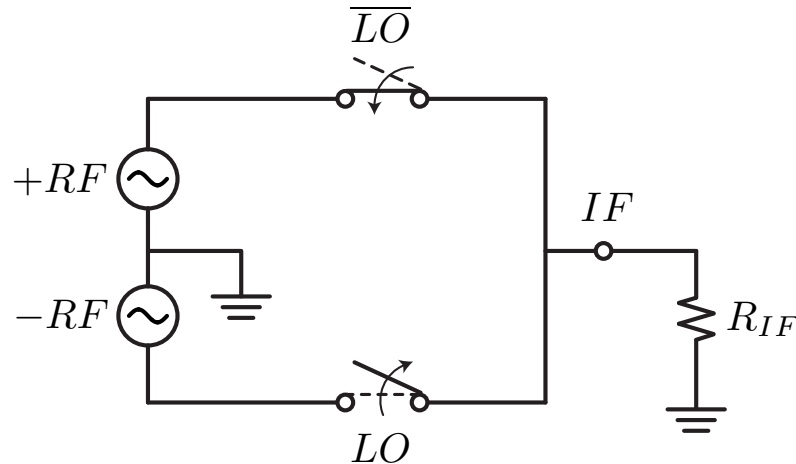

- Instead of switching currents, we can also switch the voltage.
- In the above circuit, during the  $+LO$  cycle, switch  $S1$  activates and feeds the RF to the output directly. In the  $-LO$  cycle, switch  $S2$  activates and feeds an inverted RF signal to the output.
- This circuit requires good switches that turn on hard (low on-resistance) and turn off well (good isolation).

# MOS Switching Mixer

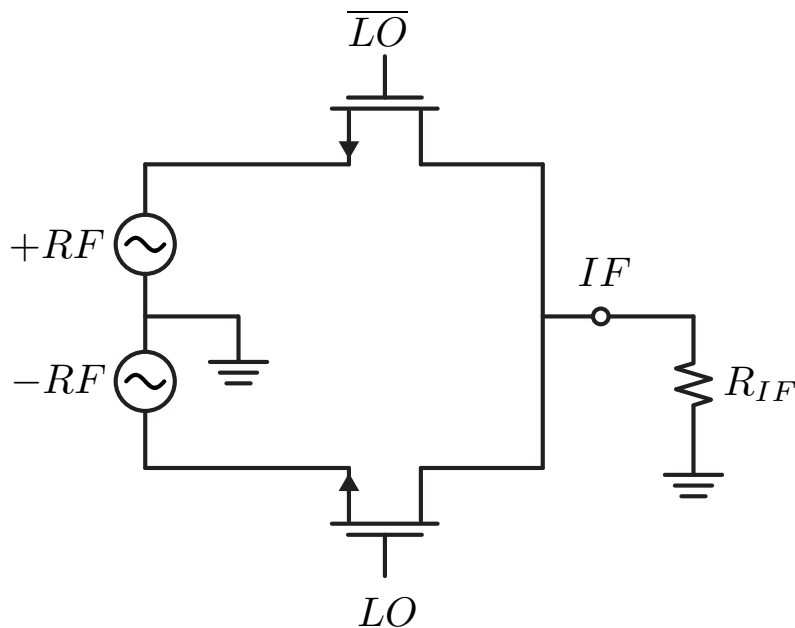

- A practical implementation uses MOS devices as switches. The devices are large to minimize their on-resistance with a limit determined by isolation (feed-through capacitance).
- We see that the RF signal is effectively multiplied by  $\pm 1$  with a rate determined by the LO signal.
- A differential RF signal is created using a balun or fed directly from a balanced LNA.

# MOS Device Feedthrough

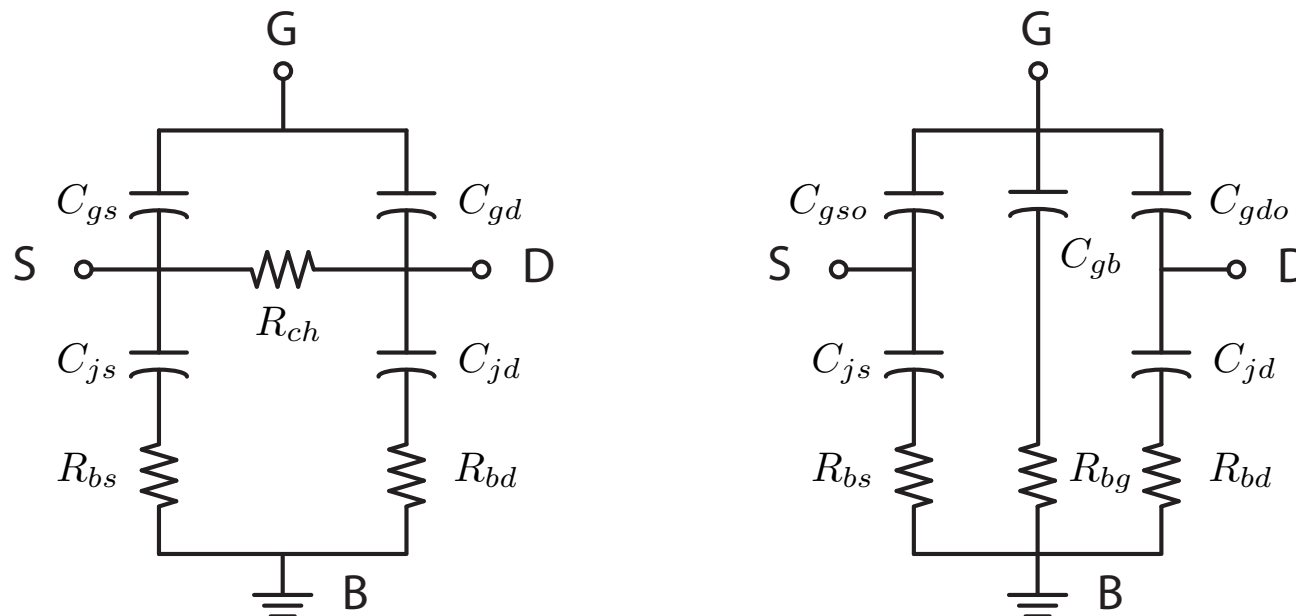

- When the device is “on”, it’s in the triode region. Due to the low on-resistance, the coupling through the substrate and LO path is minimal.
- When the device is “off”, the RF and LO leak into the IF through the overlap and substrate capacitances.

# Summary of MOS Switching Mixer

- MOS passive mixer is very linear. The device is either “on” or “off” and does not impact the linearity too much. Since there is no transconductance stage, the linearity is very good.
- The downside is that the MOS mixer is passive, or lossy. There is no power gain in the device.
- Need large LO drive to turn devices on/off
- Need to create a differential RF and LO signal. This can be done using baluns or by using a differential LNA and LO buffer.

# MOS “Ring” Mixer

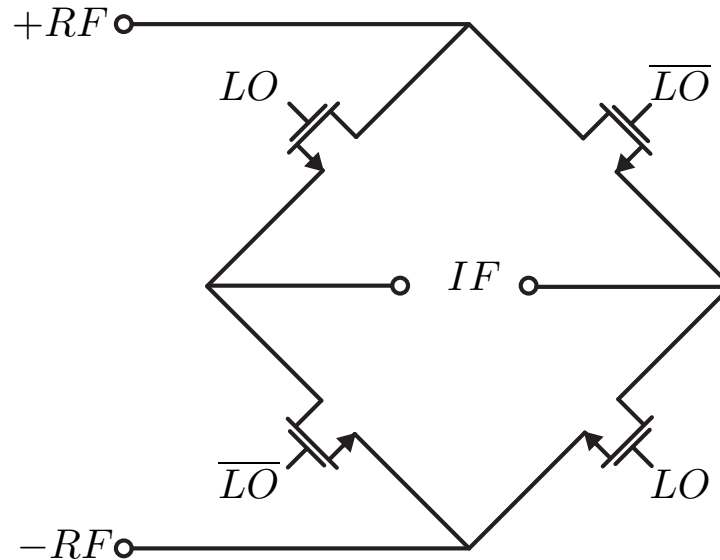

- The RF/LO/IF are all differential signals. During the positive LO cycle, the RF is coupled to the IF port with positive phase, whereas during the negative phase the RF is inverted at the IF.
- The MOS resistance forms a voltage divider with the source and load and attenuates the signal as before.

# Passive Mixer LO Power

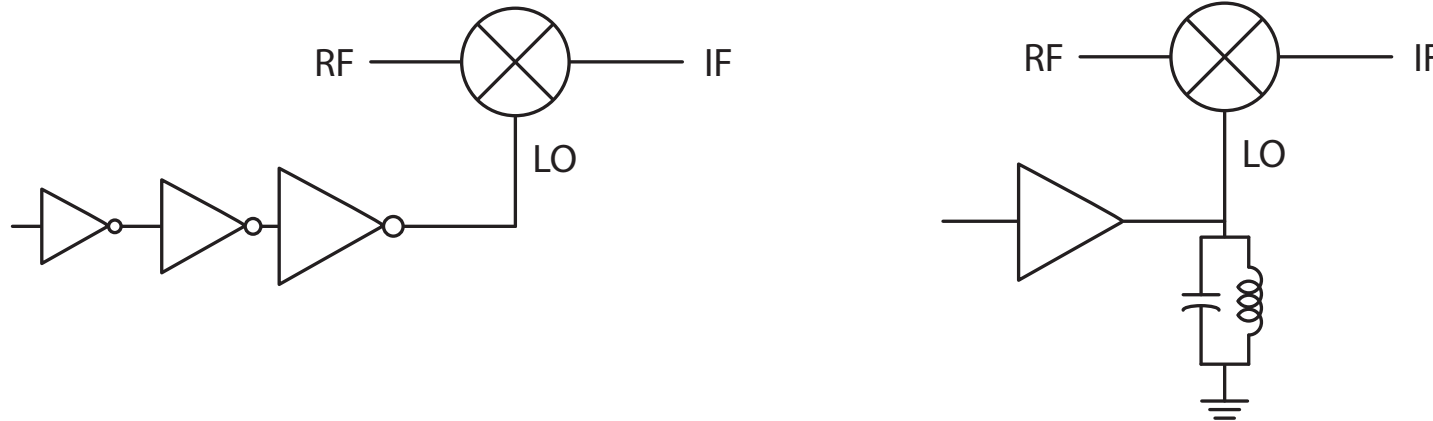

- Since gates of the MOS switches present a large capacitive load, a buffer is needed to drive them.
- The LO buffer can be realized using larger inverters (approach “square wave”) or as a tuned buffer. A tuned lowers the power by roughly  $Q$  but has a sinusoidal waveform .

# LO Power (cont)

- For an inverter chain driving the LO port, the power dissipation of the last stage is given by

$$P_{inv} = CV_{LO}^2 f_{LO}$$

- $C$  is the total load presented to the LO (two MOS devices for the double balanced mixer, one MOS device for single balanced).
- $V_{LO}$  is the LO amplitude to fully turn the devices on and off. The devices should be biased near threshold.  $f_{LO}$  is the LO frequency.

# Tuned LO Power

- For the tuned load case, the power is given by

$$P_{tuned} = \frac{V_{LO}^2}{2R_t}$$

- $R_t$  is the effective shunt resistance of the tank. Since the tank  $Q = \omega_{LO}R_tC$ , we have

$$P_{tuned} = \frac{V_{LO}^2}{2Q} \omega_{LO}C = \frac{\pi CV_{LO}^2 f_{LO}}{Q}$$

- A high  $Q$  tank helps to reduce the power consumption of the LO buffer.

# H-Bridge Ring Mixer

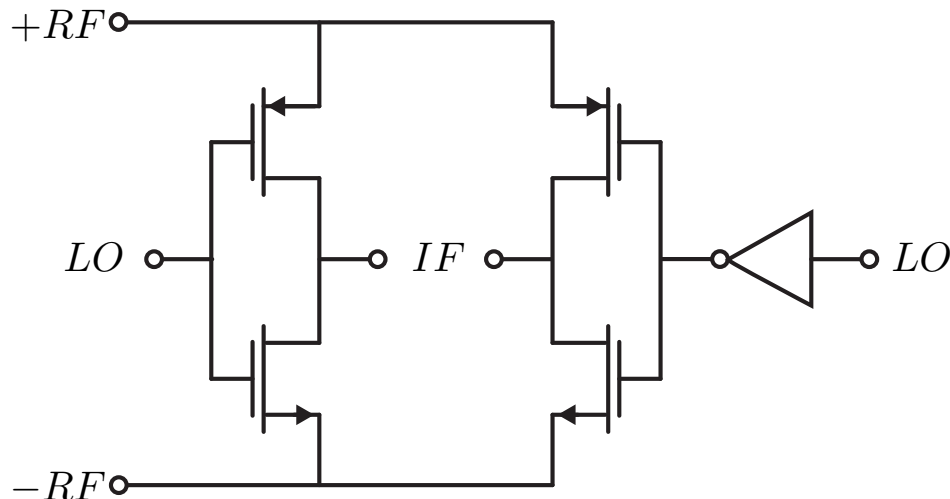

- If PMOS devices are available, two CMOS inverters form an H-Bridge, applying the RF input signal to the IF directly during the  $LO$  cycle and inverting the RF input at the IF output in the  $\overline{LO}$  cycle.
- PMOS and NMOS devices are sized appropriately to maximize on-conductance and to minimize off capacitance.

# Time-Varying Conductance

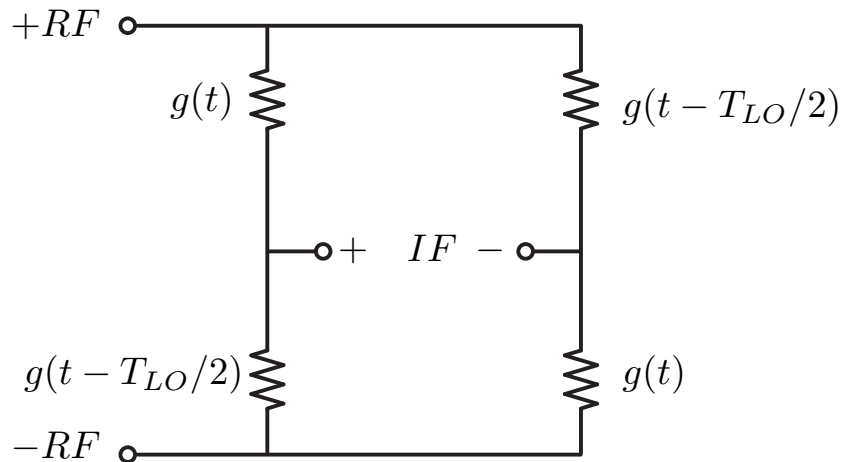

- The RF voltage is applied to a time varying conductance. Note that if the conductance of a the  $LO$  switches is given by  $g(t)$ , then the conductance of the  $\overline{LO}$  switches is given by  $g(t - T_{LO}/2)$ .

- The Thevinin equivalent source voltage is given by the open circuit voltage

$$v_T = v_{RF} \left( \frac{g(t)}{g(t) + g(t - T_{LO}/2)} - \frac{g(t - T_{LO}/2)}{g(t) + g(t - T_{LO}/2)} \right)$$

$$v_T = v_{RF} \left( \frac{g(t) - g(t - T_{LO}/2)}{g(t) + g(t - T_{LO}/2)} \right) = m(t)v_{RF}$$

# Time-Varying Gain $m(t)$

- For the MOS device and a given LO waveform, the function  $m(t)$  can be calculated and the Fourier expansion can be used to derive the gain.
- In practice there is a load capacitance  $C_{IF}$  at the IF port to filter the downconverted signal. This  $C_L$  complicates the analysis but interested students are encouraged to read the paper by Shahani, Shaeffer and Lee (JSSC vol. 32, Dec 1997, p. 2061-1071)

# “Passive” Current Mixer

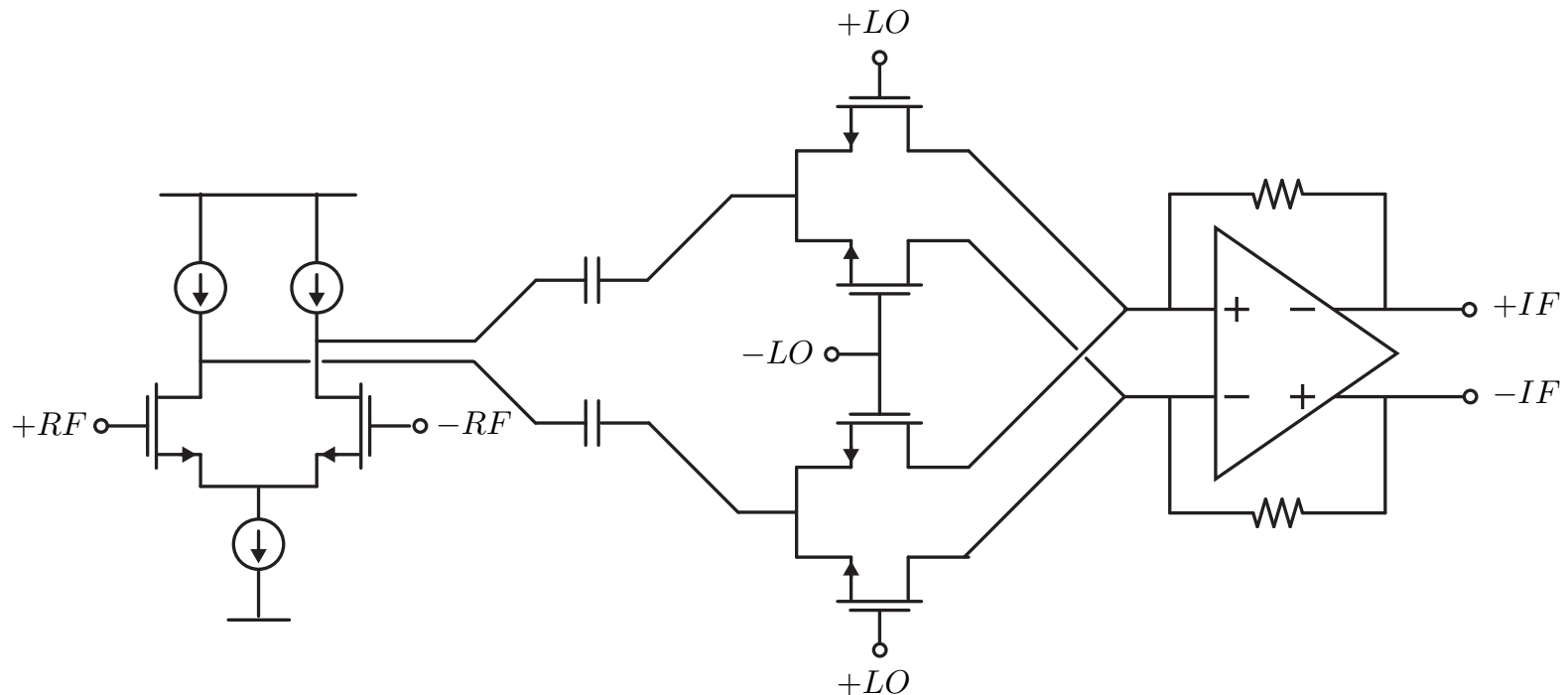

- The input stage is a  $G_m$  stage similar to a Gilbert cell mixer. The Gilbert Quad, though, has no DC current and switches on/off similar to a passive mixer.
- The output signal drives the virtual ground of a differential op-amp. The current signal is converted into a voltage output by the op-amp.

# Advantages of “Passive” Current Mixer

- No DC current in quad implies that there is no flicker noise generated by the switching quad. This is the key advantage.
- The linearity is very good since the output signal is a current. The voltage swing does not limit the linearity of the mixer. This is to be contrasted to a Gilbert cell mixer where the voltage swing is limited due to the headroom of the switching mixer and the transconductance stage.
- The op-amp output stage can be converted into an IF filter (discussed later)

# Disadvantages of Mixer

- Need large LO drive compared to the active Gilbert cell mixer.
- Need an op-amp. This requires extra power consumption and introduces additional noise.
- Need a common mode feedback circuit at the input of the op-amp.

# Ring or Quad?

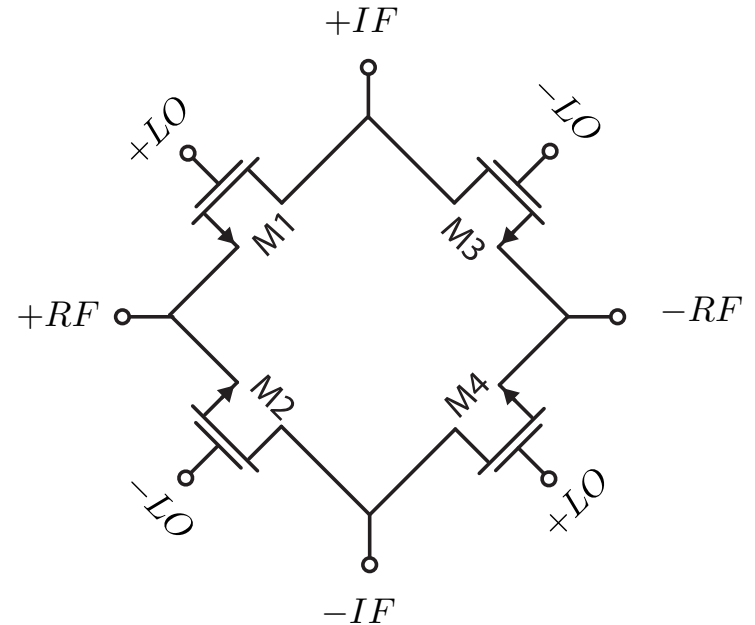
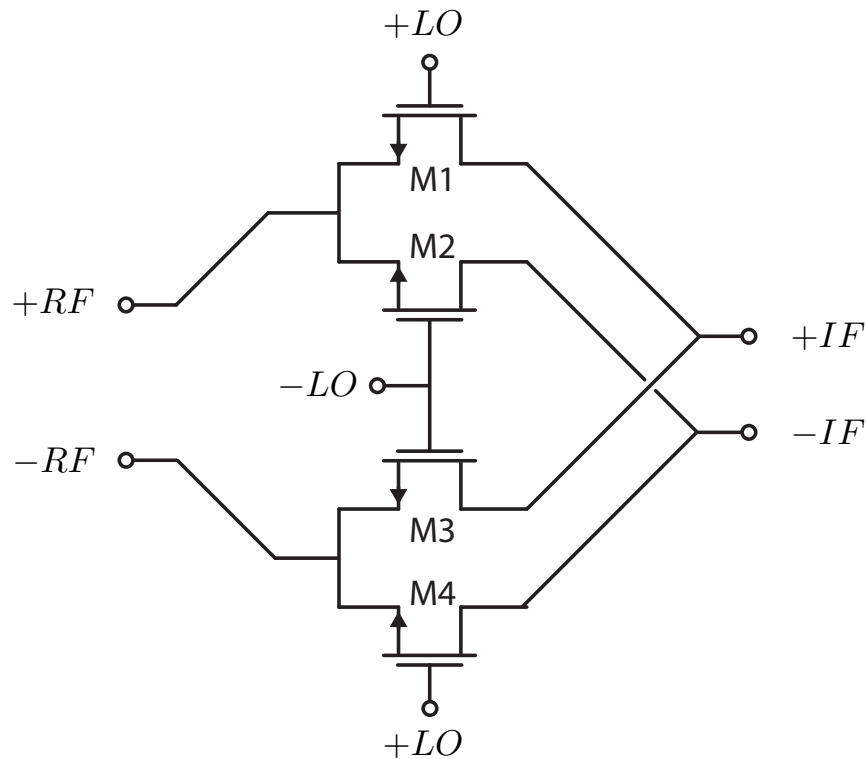

- Note that the Gilbert quad is really a folded ring. Thus the passive and active mixers are very similar. The main difference is how the quad devices are biased. In the Gilbert cell they are biased nominally in saturation and have DC current. In the passive mixers, they are biased near the threshold.

# Op-Amp Noise

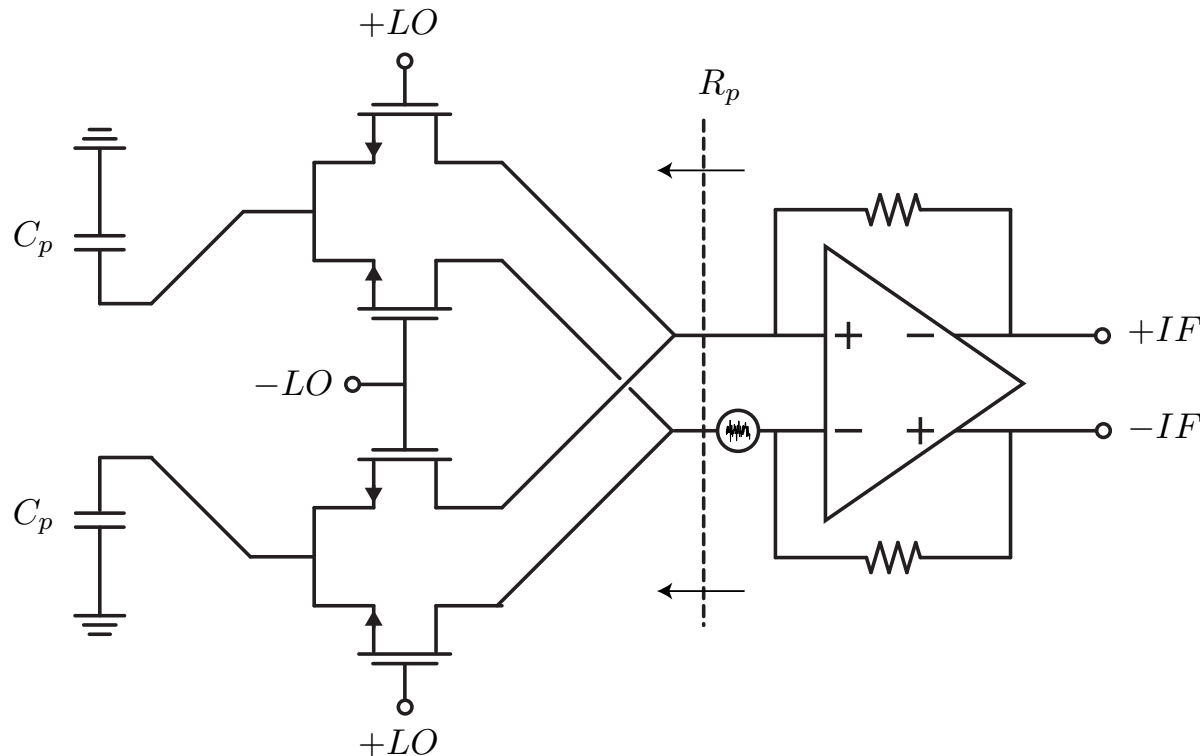

- The op-amp input referred noise is amplified to IF. The resistance seen at the op-amp input terminals is actually a switched capacitor resistor!
- The parasitic capacitance at the output of the transconductance stage is charged and discharged at the rate of the LO.

# Switched Capacitor Resistor

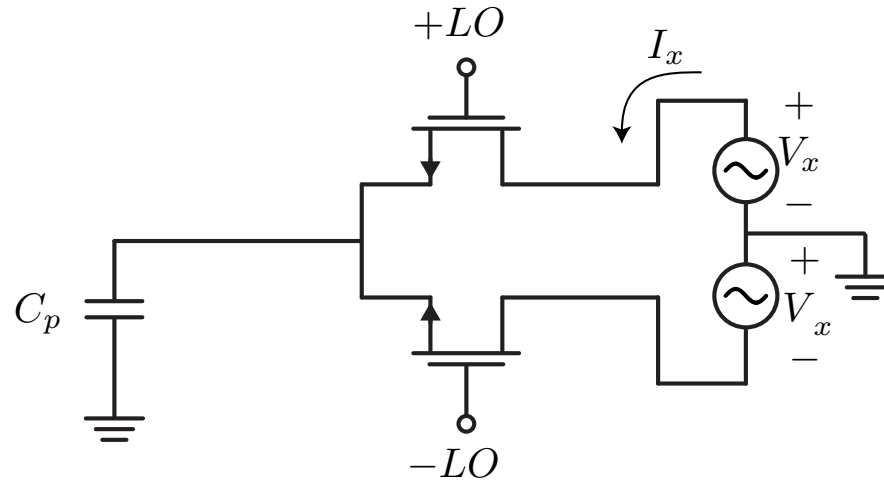

- Note that the parasitic capacitances are charged at the rate of the LO to the input voltage  $V_x$ , and then to the  $-V_x$ , every cycle.
- The total charge transferred during a period is given by

$$Q_{tot} = C_p V_x - (-C_p V_x) = 2C_p V_x$$

- The net current is given by  $I_x = \frac{Q_{tot}}{T_{LO}} = 2C_p V_x f_{LO}$

# Switched Capacitor Resistor (cont)

- Since there are two differential pairs connected to the op-amp terminals in parallel, the total charge is twice. So the effective resistance seen at this node is given by

$$R_p = \frac{V_x}{2I_x}$$

- The effective resistance is therefore given by

$$R_p = \frac{1}{4f_{LO}C_p}$$

- This is a switched capacitor “resistors”.

# Op-Amp Noise Transfer

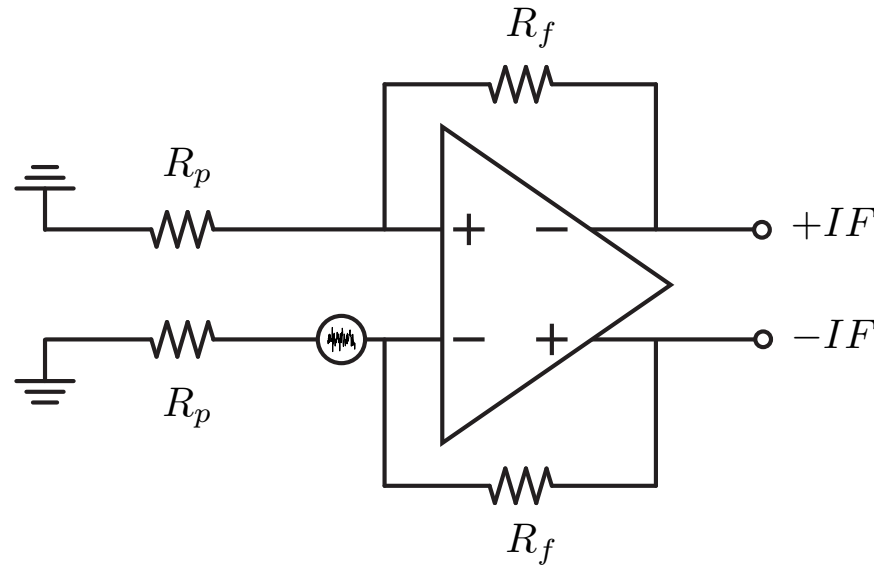

- The noise is thus transferred to the output with transfer function given by

$$\overline{v_o^2} = \left(1 + \frac{2R_f}{R_p}\right)^2 \overline{v_{amp}^2}$$

- To minimize this noise, we have to minimize the parasitic capacitance  $C_p$  and the op-amp noise.

# Output Filter Stage

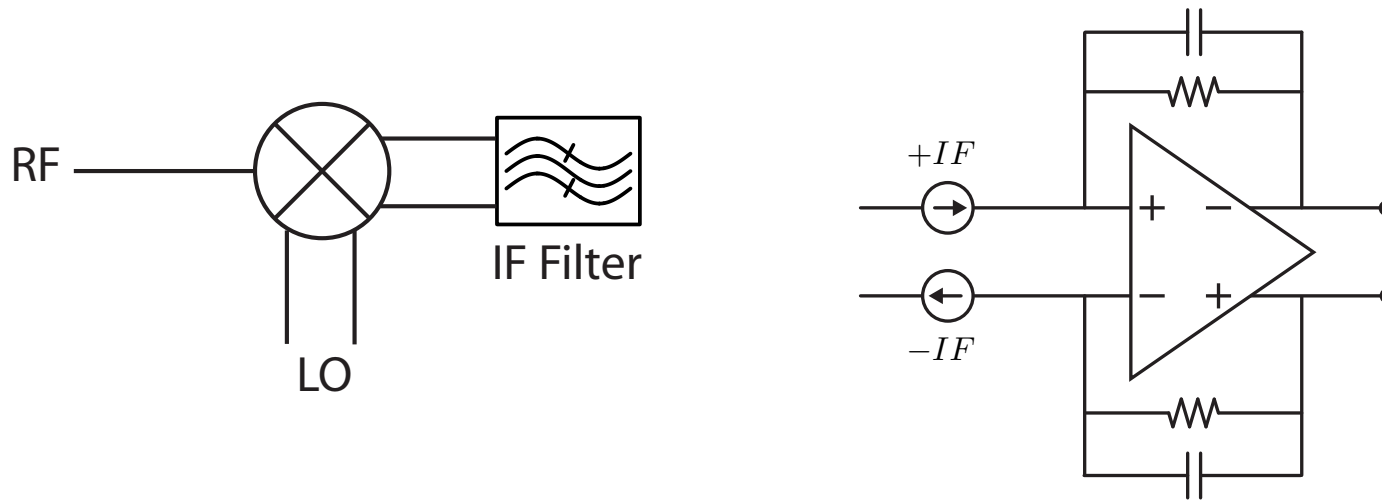

- Since a down-conversion mixer will naturally drive a filter, we see that the output current can be used directly to drive a current mode filter.
- For instance, the op-amp can be absorbed into the first stage of a multi-stage op-amp RC IF filter. The feedback resistor  $R_f$  is shunted with a capacitor  $C_f$  to produce a pole.

# Diode Mixers

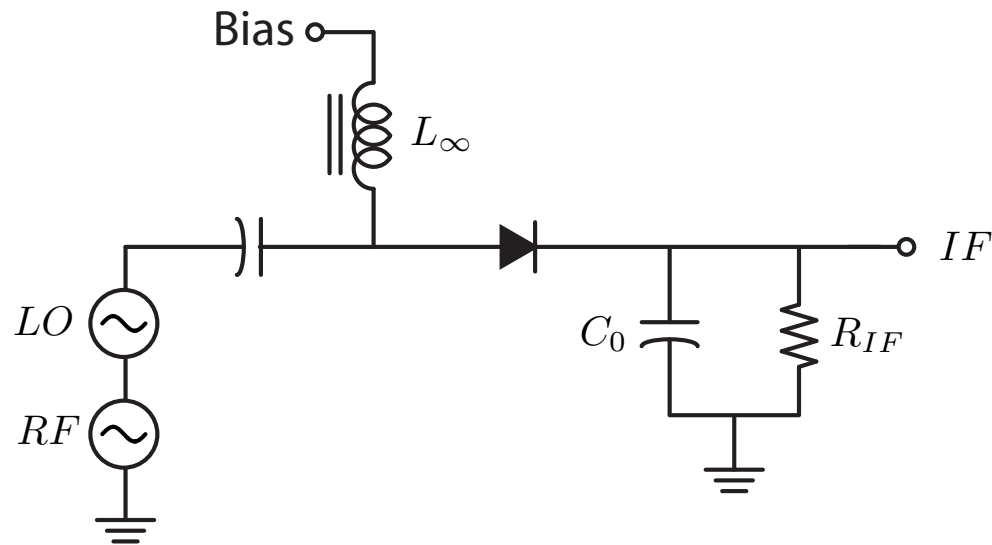

- If MOS devices are not available, or if the frequency exceeds the capability of the MOS devices, diodes can be used as switch elements.
- Here the diode is biased into “on” state by the chokes and bypass capacitors. A strong LO signal, though, can turn the diode off.

# Weak LO Diode Mixer

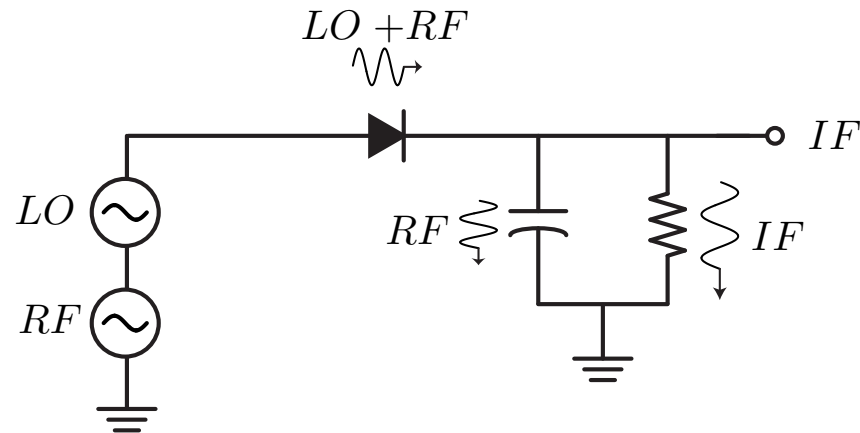

- The RF signal “riding” on top of the LO signal is thus mixed by the switching action.
- Note that if the LO signal is weak, then mixing action occurs by the non-linearity of the diode. But this mode has a smaller conversion gain and produces more distortion.

# Diode Ring Mixer

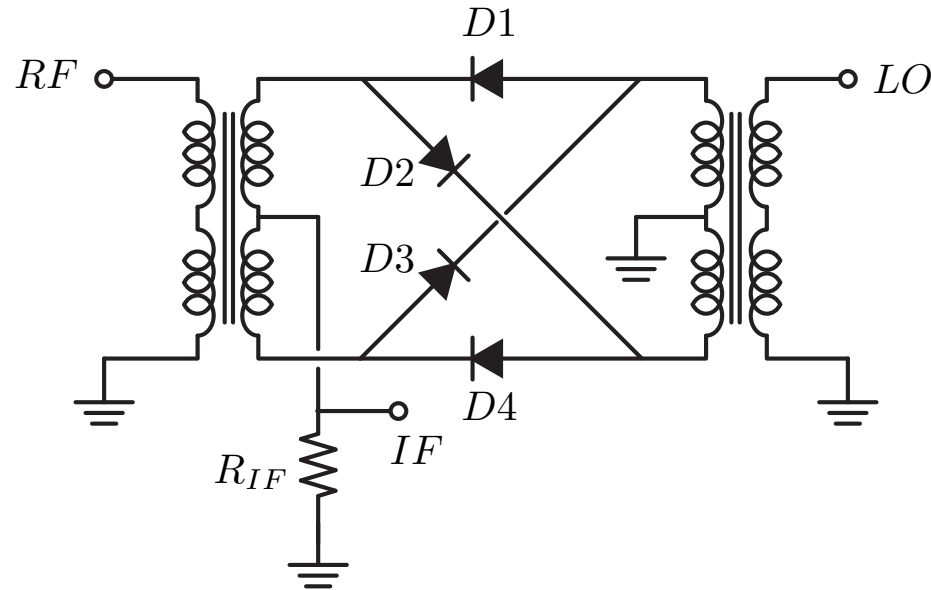

- The ring mixer is a passive mixer. Typical loss numbers are about 6 dB. The mixer has good isolation. The  $LO \longleftrightarrow RF$  isolation comes from the transformers. The balanced operation results in  $RF$  and  $LO$  rejection.
- The LO signal drive is large since it must turn on/off diodes.

# Mixer Description

- The ring mixer is a fully balanced mixer but we have the option of driving the LO and RF single ended. As we shall see, the LO signal alternatively turns on diodes D1/D2 or D3/D4 thereby connecting the RF voltage to the IF with alternatively polarity.
- During a positive LO voltage, the secondary of the LO transformer applies a positive voltage across D1 in series with the load  $R$  thereby forward biasing the diode.
- Likewise, the secondary terminal of the LO transformer applies a negative voltage to the cathode of D2, thereby forward biasing it in series with the load.
- Diodes D3/D4 are reverse biased and therefore open circuits (ideally).

# Positive LO Cycle

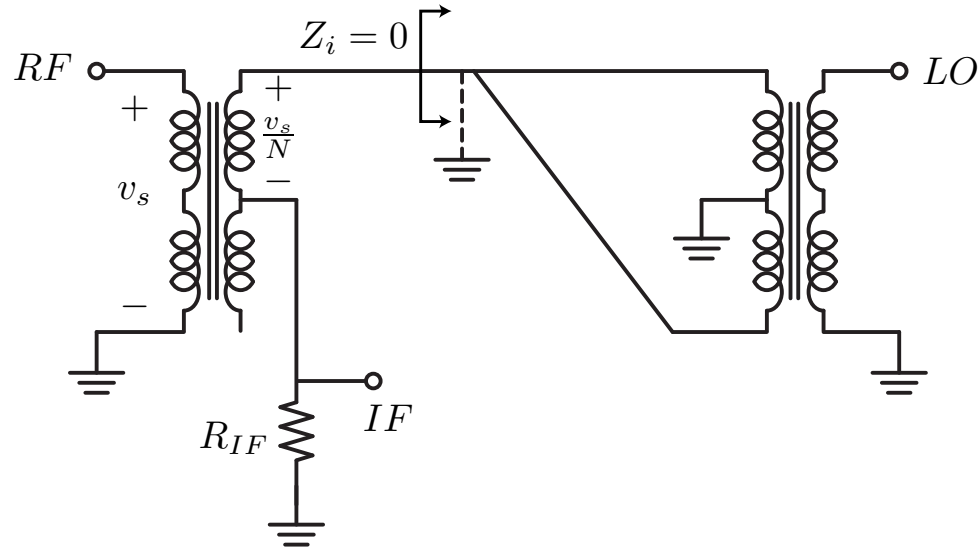

- The equivalent circuit above shows small resistor representing the diode on resistance.
- The RF signal is applied to the load through the center tap of the transformer. We shall show that the impedance looking into the transformer is low (ideally zero), and thus the entire RF signal at the secondary terminal is applied to the load  $v_o = -v_s/N$

# LO Transformer

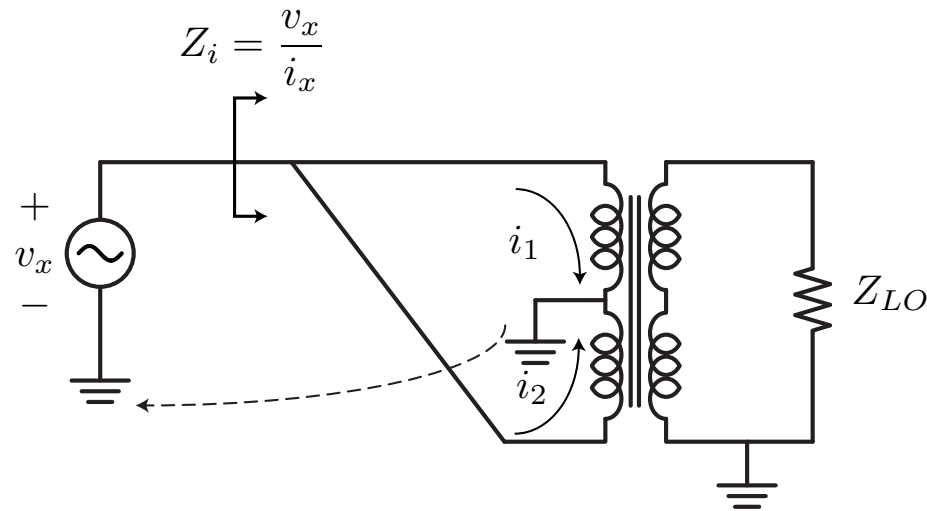

- Note the input impedance looking into the LO transformer is ideally short circuit. To see this, apply a test voltage  $v_x$  to this node.
- If we ignore the effect of the LO signal for now, we see that two equal currents  $i_1 = i_2 = i_x/2$  flow into the secondary of the LO transformer. The return current comes from the center tap ground.

# LO Transformer (cont)

- The induced voltage at the primary is given by

$$v_1 = j\omega(M_{12} - M_{13})i_x/2 \equiv 0$$

- This is because  $M_{13} = M_{12}$  and the currents on the secondary are out of phase.
- The voltages induced on the secondary side are likewise zero (assuming perfect coupling)

$$v_2 = j\omega L_2 i_x/2 + j\omega M_{23}(-i_x/2) \equiv 0$$

$$v_3 = j\omega L_3(-i_x/2) + j\omega M_{32}i_x/2 \equiv 0$$

# Negative LO Cycle

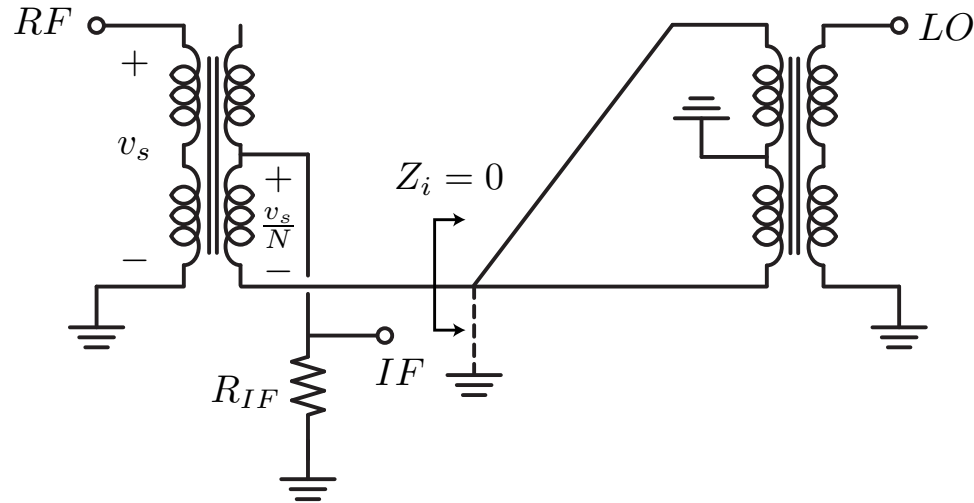

- By symmetry, during the negative LO cycle, the mixer simplifies to the above equivalent circuit.
- During this cycle, the RF signal is applied to the load through the center tap and the bottom of the transformer, thus producing an output signal in phase with the RF

$$v_o = +v_s/N$$

# Diode Ring Mixer Operation

- The operation is thus similar to the double balanced Gilbert cell mixer in voltage mode. The RF voltage is multiplied by  $\pm 1$  with a rate of the LO signal.
- The lack of DC means that the RF is rejected at the IF port. Likewise, the LO/RF signals are isolated by the switches. The only feed-through occurs due to reverse isolation of the diodes.
- The biggest drawback, though, is the bulky transformers and the large LO drive. The mixer is very linear and quite attractive in applications where linearity reigns supreme over power consumption.
- At microwave frequencies, the transformers can be replaced by couplers. Since diodes can operate up to extremely high frequencies (THz), the entire circuit can work up to THz region.