

## *Lecture 16: Amplifier Noise Calculations*

Prof. Ali M. Niknejad

University of California, Berkeley

Copyright © 2008 by Ali M. Niknejad

# Recap from Last Lecture

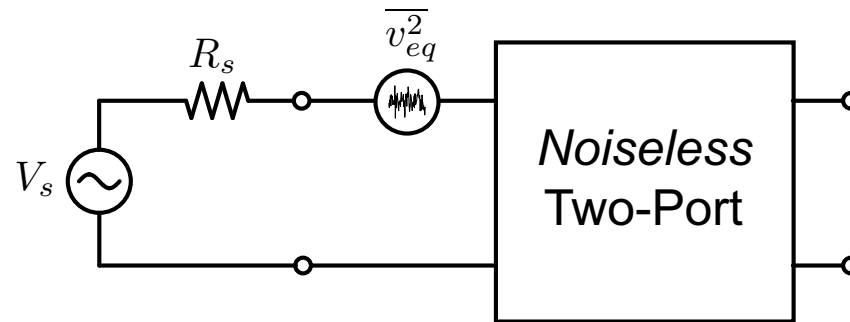

- Last lecture we calculated the total output noise from a two-port by ignoring the correlation of the input noise generators.
- The equivalent noise *voltage* is given by

$$v_{eq} = v_n + Z_S i_n$$

- Last lecture we assumed uncorrelated noise sources, so  $\overline{v_{eq}^2} = \overline{v_n^2} + |Z_S|^2 \overline{i_n^2}$
- If we take the correlation into account, our results will be true for a general circuit.

# Correlated Noise Sources

- Let's partition the input noise current into two components, a component correlated (“parallel”) to the noise voltage and a component uncorrelated (“perpendicular”) of the noise voltage

$$i_n = i_c + i_u$$

- where we assume that  $\langle i_u, v_n \rangle = 0$  and

$$i_c = Y_C v_n$$

- We can therefore write

$$v_{eq} = v_n(1 + Y_C Z_S) + Z_S i_u$$

# Noise Figure of Two-Port

- Which is a sum of uncorrelated random variables. The variance is thus the sum of the variances

$$\overline{v_{eq}^2} = \overline{v_n^2}|1 + Y_C Z_S|^2 + |Z_s|^2 \overline{i_u^2}$$

- This allows us to immediately write the noise figure as

$$F = 1 + \frac{\overline{v_n^2}|1 + Y_C Z_S|^2 + |Z_s|^2 \overline{i_u^2}}{\overline{v_s^2}}$$

- Let  $\overline{v_n^2} = 4kTBR_n$ ,  $\overline{i_u^2} = 4kTBG_u$ , and  $\overline{v_s^2} = 4kTBR_s$ . Then

$$F = 1 + \frac{R_n|1 + Y_C Z_S|^2 + |Z_s|^2 G_u}{R_s}$$

# Optimum Source Impedance

- If we let  $Y_c = G_c + jB_c$ ,  $Y_s = Z_s^{-1} = G_s + jB_s$ , it's not too difficult to show that the optimum source impedance to minimize  $F$  is given by

$$B_{opt} = B_s = -B_c$$

$$G_{opt} = G_s = \sqrt{\frac{G_u}{R_n} + G_c^2}$$

- The minimum achievable noise figure is

$$F_{min} = 1 + 2G_c R_n + 2\sqrt{R_n G_u + G_c^2 R_n^2}$$

- For  $G_c = 0$ , this reduces to our previously derived expression.

# Minimum Noise $F_{min}$

- Very similar to last lecture, we have

$$F = F_{min} + \frac{R_n}{G_s} |Y_s - Y_{opt}|^2$$

- This equation states that if the source impedance  $Y_s \neq Y_{opt}$ , the noise figure will be larger by a factor of the “distance” squared times the factor  $R_n/G_s$ .
- A good device should have a low  $R_n$  so that the noise match is not too sensitive.

# FET Common Source Amplifier

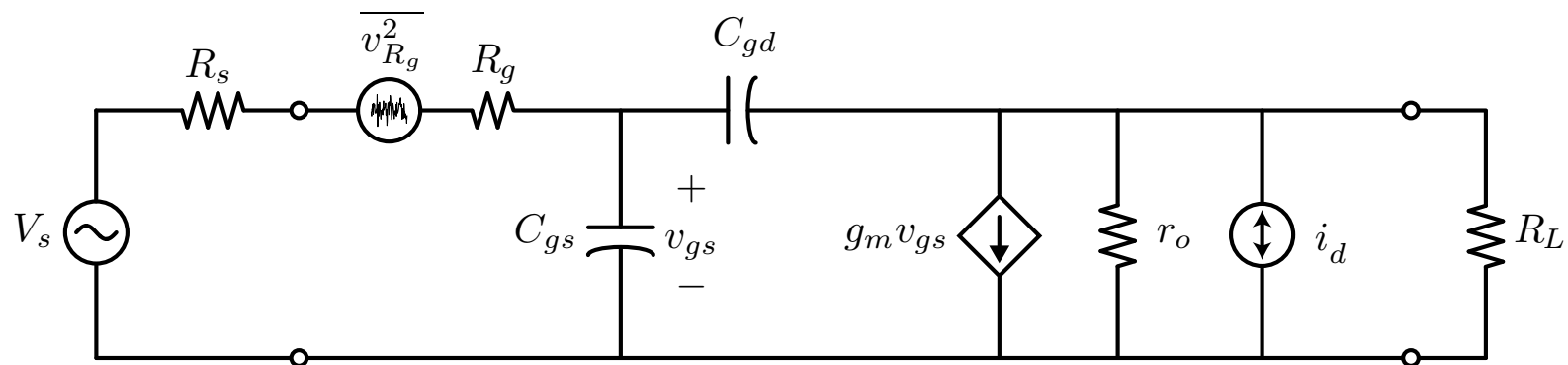

- Consider the following noise sources:

$$R_s \quad \overline{v_s^2} = 4kTB R_s$$

$$R_g \quad \overline{v_g^2} = 4kTB R_g$$

$$R_{ch} \quad \overline{i_d^2} = 4kTB g_{d0} \gamma B$$

$$R_L \quad \overline{i_L^2} = 4kTB G_L$$

# Total FET Drain Noise

- Summing all the noise at the output (assume low frequency)

$$\overline{i_o^2} = \overline{i_d^2} + \overline{i_L^2} + (\overline{v_g^2} + \overline{v_s^2})g_m^2$$

- Which results in the noise figure

$$F = 1 + \frac{\overline{v_g^2}}{\overline{v_s^2}} + \frac{\overline{i_d^2} + \overline{i_L^2}}{g_m^2 \overline{v_s^2}}$$
$$= 1 + \frac{R_g}{R_s} + \frac{g_{d0}\gamma + G_L}{R_s g_m^2}$$

# FET Noise Figure (low freq)

- Assume  $g_m = g_{d0}$  (long channel)

$$= 1 + \frac{R_g}{R_s} + \frac{\gamma}{g_m R_s} + \frac{G_L G_S}{g_m^2}$$

- If we make  $g_m$  sufficiently large, the gate resistance will dominate the noise.
- The gate resistance has two components, the physical gate resistance and the induced channel resistance

$$R_G = R_{poly} + \delta R_{ch} = \frac{1}{3} \frac{W}{L} R_{\square} + \frac{1}{5} \frac{1}{g_m}$$

- The factors  $1/3$  and  $1/5$  come from a distributed analysis (EECS 117). They are valid for single-sided gate contacts.

# FET Layout

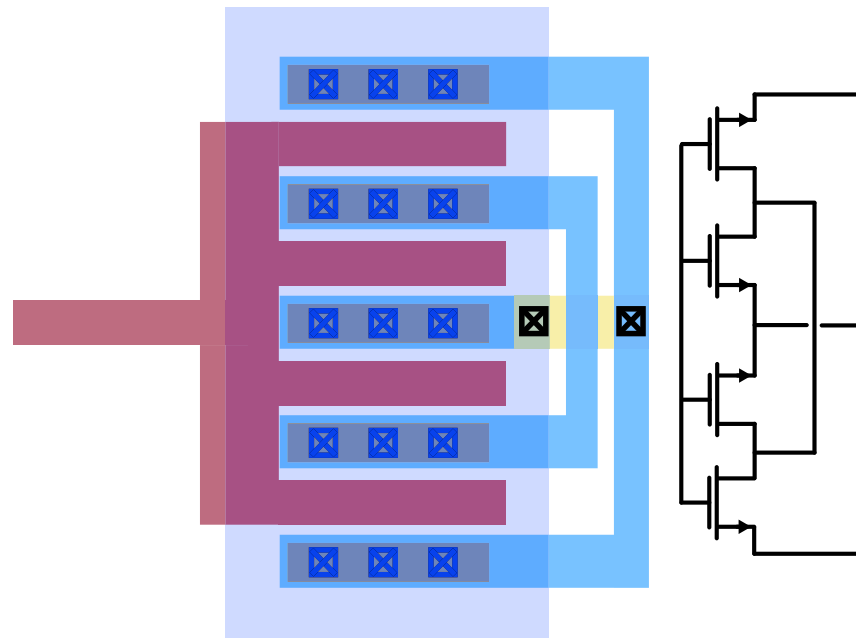

- To reduce the gate resistance, a multi-finger layout approach is commonly adopted. As a bonus, the junction capacitance is reduced due to the junction sharing.

# CS Noise at Medium Frequencies

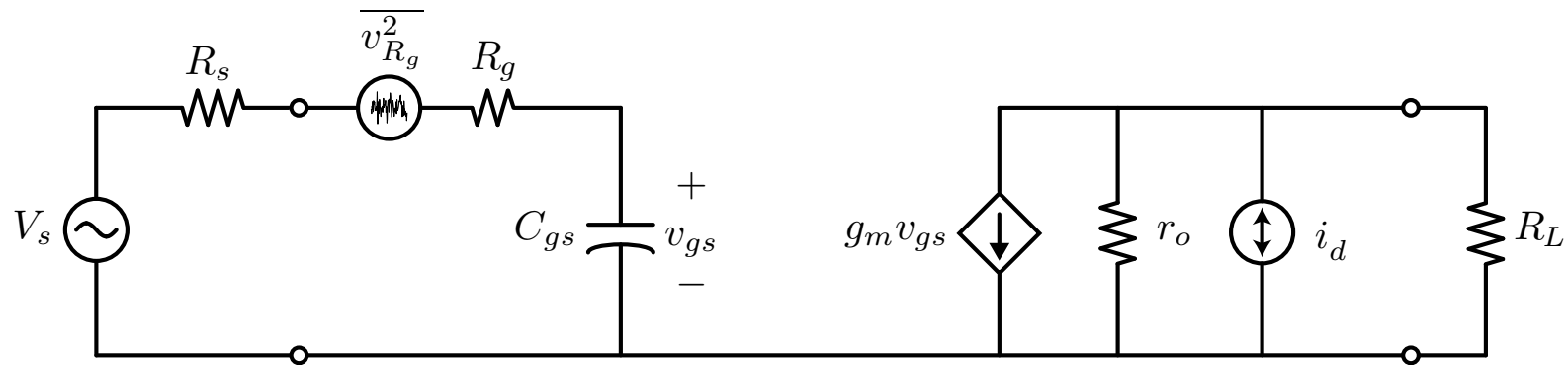

- If we repeat the calculation at medium frequencies, ignoring  $C_{gd}$ , we simply need to input refer the drain noise taking into account the frequency dependence of  $G_m$

$$G_m = \frac{1/(j\omega C_{gs})}{1/(j\omega C_{gs}) + R_s + R_g}$$

$$= \frac{1}{1 + j\omega C_{gs}(R_s + R_g)}$$

# CS Noise (cont)

- The drain noise is input referred by the magnitude squared

$$|G_m|^{-2} = 1 + \omega^2 C_{gs}^2 (R_s + R_g)^2$$

- So the noise figure is simply given by (neglect the noise of  $R_L$ )

$$F = 1 + \frac{R_g}{R_s} + \frac{\gamma}{\alpha} (1 + \omega^2 C_{gs}^2 (R_s + R_g)^2)$$

- Assume that  $g_m R_s \gg 1$  and  $R_s \gg R_g$  (good layout). The “high” frequency noise is given by

$$F_\infty = 1 + \frac{\gamma}{\alpha} \frac{\omega^2 C_{gs}^2 R_s^2}{g_m R_s} = 1 + \frac{\gamma}{\alpha} \left( \frac{\omega}{\omega_T} \right)^2 g_m R_s$$

# MOSFET LNA Design

- Two important specifications for an LNA are a power impedance match and low noise figure. We see that the noise figure of an LNA using MOSFETs can be made low by increasing the  $g_m$  of the device and with proper layout (multi-finger device).
- But the gate of a MOSFET is predominantly capacitive which presents a bad match to  $50\Omega$
- Do we really need to do a power match? We may be willing to give up some gain. Is this a wise decision?

# To Match or Not to Match?

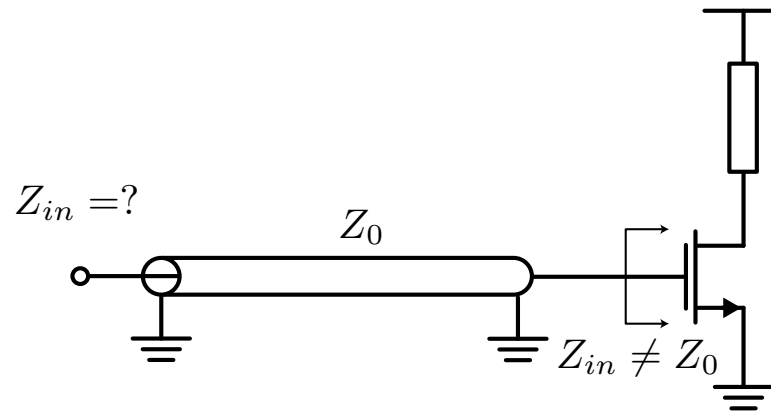

- An age old question in RF is the requirement to match. Is it necessary?
- Imagine that the input impedance is not matched. Now imagine the path from the antenna to the amplifier. It will usually go through a transmission line, either a cable or through PCB traces, before reaching the LNA.

# To Match or Not to Match? (cont)

- If the LNA input is not matched, the impedance seen by the antenna depends on the length of this transmission line (EECS 117). This is a bad situation because we cannot predict how much power will reach the LNA !
- But if we match, then you're certain that regardless of the length of the T-line, the input power is well known and fixed. Furthermore, if a filter precedes the LNA (very common), the filter must be terminated properly to operate with low insertion loss.
- How about simply terminating the input gate with a resistor equal to  $R_s$ ? If the capacitance of the gate is low, the input impedance will be mostly  $50\Omega$ .

# Input Termination

- Let's take the most optimistic situation where the MOSFET noise is negligible. Then the noise figure due to the input termination resistor is bounded by

$$F > 1 + \frac{\overline{v_{eq}^2}}{v_s^2} = 2$$

- The termination adds 3 dB of noise figure! In sub-dB applications this is totally intolerable. In other applications, though, this may be a cheap and simple solution.

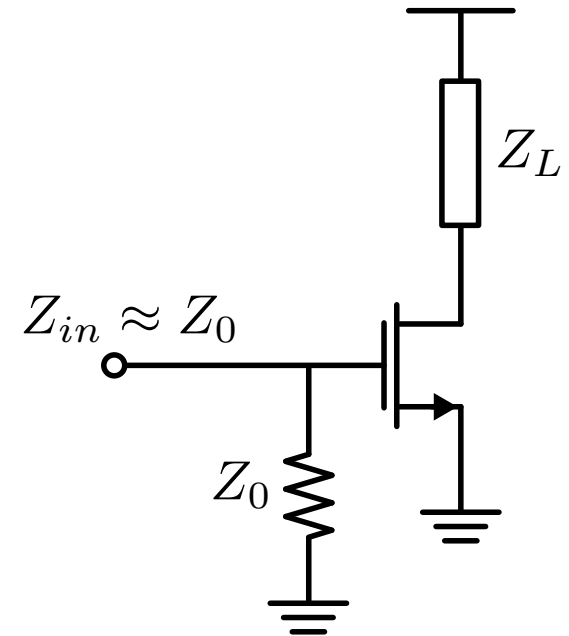

# Common Gate LNA

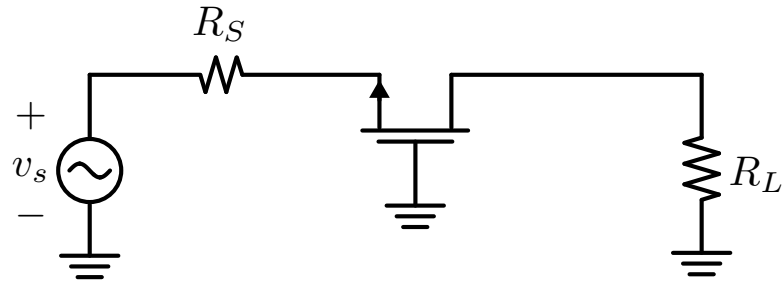

- A common gate LNA can impedance match by choosing  $g_m = G_s$ . For a FET this requires a high current (due to lower  $g_m$ ) for  $R_s = 50\Omega$ .
- Let's calculate the noise figure by just considering the effect of the drain current. Since the drain current is injected into the input, it adds noise in shunt with the input noise current

$$F > 1 + \frac{\overline{i_d^2}}{\overline{i_s^2}}$$

# Common Gate LNA (cont)

- Substitute  $\overline{i_s^2} = 4kTBG_s$  and  $\overline{i_d^2} = 4kT\gamma g_{ds0} = 4kT\frac{\gamma}{\alpha}g_m$  and further note that  $g_m = G_s$

$$F > 1 + \frac{\gamma g_m}{\alpha G_s} = 1 + \frac{\gamma}{\alpha}$$

- $\gamma/\alpha = 2/3$  for a long channel device. For short channel devices, this is about 2.

$$F \geq 1 + \frac{\gamma}{\alpha} \approx 2 - 3$$

- The noise figure is large relative to  $F_{min}$ . The common source amplifier is attractive since its noise can be made close to the  $F_{min}$  of the device.

# LC Matched LNA

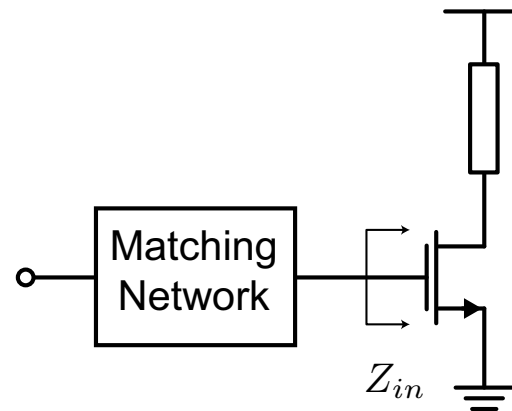

- We can always match the input impedance of an LNA to  $50\Omega$  using one of the matching circuits we studied earlier.
- But the matching network will also transform  $R_s$  and it may worsen the noise figure (by moving  $R_s$  further away from  $R_{S,opt}$ ).

# LC Match (cont)

- Another issue is that the input resistance of the FET is quite small (series resistance). Recall that

$$Z_g = \frac{1}{j\omega C_{gs}} + R_i + R_G \approx R_i + \frac{1}{j\omega C_{gs}}$$

- where for a good layout we have minimized the gate resistance  $R_G$ . The intrinsic channel resistance is related to the device  $g_m$

$$Z_g = \frac{1}{5g_m} + \frac{1}{j\omega C_{gs}}$$

- Since the real part is typically rather small, the  $Q$  factor of the matching network may be quite large.