

EECS 142



Integrated Circuits for Communication

Lecture 14: Electrical Noise

Prof. Ali M. Niknejad

University of California, Berkeley

Copyright © 2008 by Ali M. Niknejad

Introduction to Noise

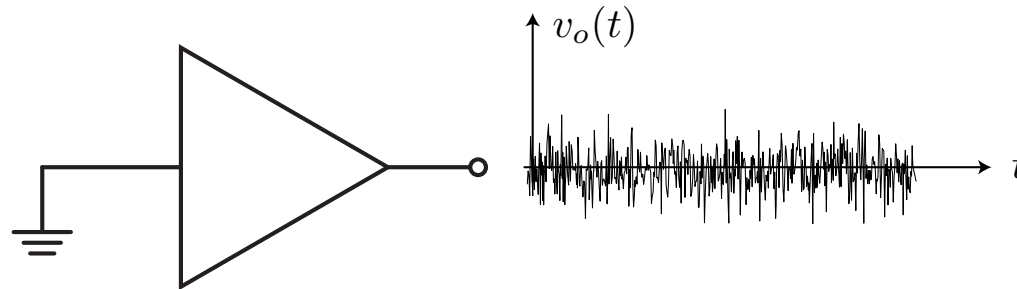

- All electronic amplifiers generate noise. This noise originates from the random thermal motion of carriers and the discreteness of charge.
- Noise signals are random and must be treated by statistical means. Even though we cannot predict the actual noise waveform, we can predict the statistics such as the mean (average) and variance.

Noise Power

- The average value of the noise waveform is zero

$$\overline{v_n(t)} = \langle v_n(t) \rangle = \frac{1}{T} \int_T v_n(t) dt = 0$$

- The mean is also zero if we freeze time and take an infinite number of samples from identical amplifiers.
- The variance, though, is non-zero. Equivalently, we may say that the signal power is non-zero

$$\overline{v_n(t)^2} = \frac{1}{T} \int_T v_n^2(t) dt \neq 0$$

- The RMS (root-mean-square) voltage is given by

$$v_{n,rms} = \sqrt{\overline{v_n(t)^2}}$$

Power Spectrum of Noise

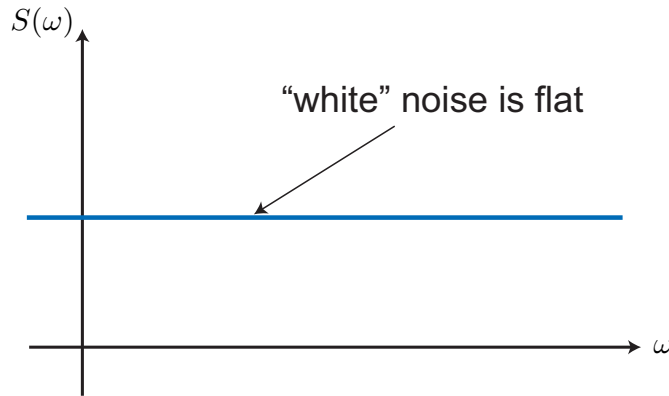

The power spectrum of the noise shows the concentration of noise power at any given frequency. Many noise sources are “white” in that the spectrum is flat (up to extremely high frequencies)

- In such cases the noise waveform is totally unpredictable as a function of time. In other words, there is absolutely no correlation between the noise waveform at time t_1 and some later time $t_1 + \delta$, no matter how small we make δ .

Thermal Noise of a Resistor

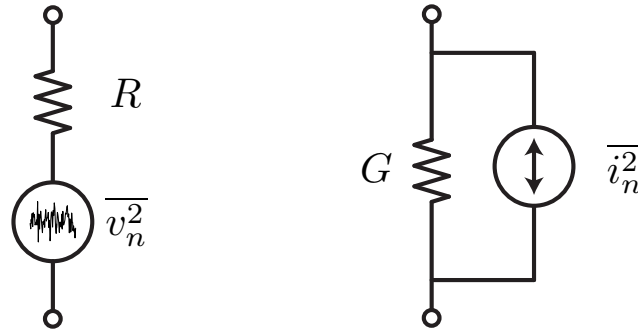

- All resistors generate noise. The noise power generated by a resistor R can be represented by a series voltage source with mean square value $\overline{v_n^2}$

$$\overline{v_n^2} = 4kTRB$$

- Equivalently, we can represent this with a current source in shunt

$$\overline{i_n^2} = 4kTGB$$

Resistor Noise Example

- Here B is the bandwidth of observation and kT is Boltzmann's constant times the temperature of observation
- This result comes from thermodynamic considerations, thus explaining the appearance of kT
- Often we speak of the “spot noise”, or the noise in a specific narrowband δf

$$\overline{v_n^2} = 4kTR\delta f$$

- Since the noise is white, the shape of the noise spectrum is determined by the external elements (L 's and C 's)

Resistor Noise Example

- Suppose that $R = 10\text{k}\Omega$ and $T = 20^\circ\text{C} = 293\text{K}$.

$$4kT = 1.62 \times 10^{-20}$$

$$\overline{v_n^2} = 1.62 \times 10^{-16} \times B$$

$$v_{n,rms} = \sqrt{\overline{v_n(t)^2}} = 1.27 \times 10^{-8} \sqrt{B}$$

- If we limit the bandwidth of observation to $B = 10^6\text{MHz}$, then we have

$$v_{n,rms} \approx 13\mu\text{V}$$

- This represents the limit for the smallest voltage we can resolve across this resistor in this bandwidth

Combination of Resistors

- If we put two resistors in series, then the mean square noise voltage is given by

$$\overline{v_n^2} = 4kT(R_1 + R_2)B = \overline{v_{n1}^2} + \overline{v_{n2}^2}$$

- The noise powers add, *not* the noise voltages
- Likewise, for two resistors in parallel, we can add the mean square currents

$$\overline{i_n^2} = 4kT(G_1 + G_2)B = \overline{i_{n1}^2} + \overline{i_{n2}^2}$$

- This holds for any pair of independent noise sources (zero correlation)

Resistive Circuits

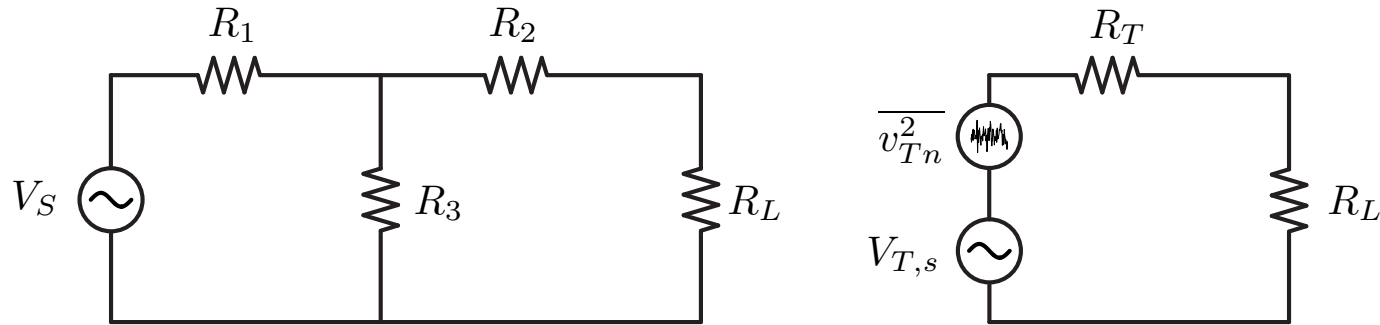

- For an arbitrary resistive circuit, we can find the equivalent noise by using a Thevenin (Norton) equivalent circuit or by transforming all noise sources to the output by the appropriate *power gain* (e.g. voltage squared or current squared)

$$V_{T,s} = V_S \frac{R_3}{R_1 + R_3}$$

$$\overline{v_{Tn}^2} = 4kTR_TB = 4kT(R_2 + R_1 || R_3)B$$

Noise for Passive Circuits (I)

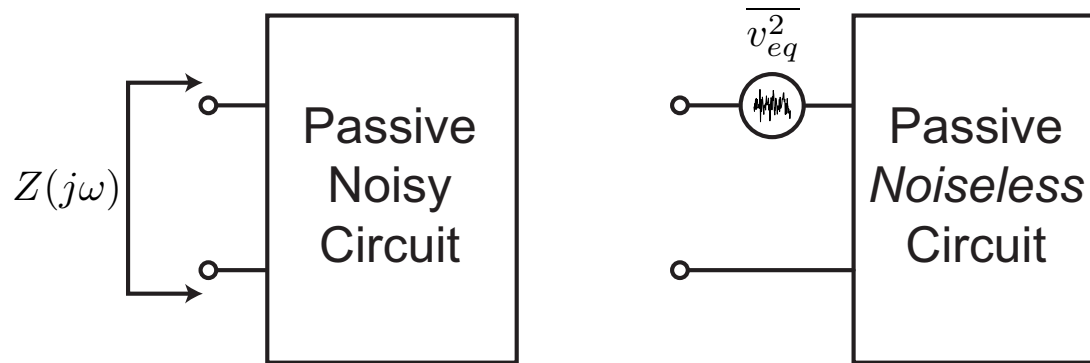

- For a general linear circuit, the mean square noise voltage (current) at any port is given by the equivalent input resistance (conductance)

$$\overline{v_{eq}^2} = 4kT\Re(Z(f))\delta f$$

Noise for Passive Circuits (II)

- This is the “spot” noise. If the network has a filtering property, then we integrate over the band of interest

$$\overline{v_{T,eq}^2} = 4kT \int_B \Re(Z(f))df$$

- Unlike resistors, L 's and C 's *do not* generate noise. They do shape the noise due to their frequency dependence.

Example: Noise of an RC Circuit

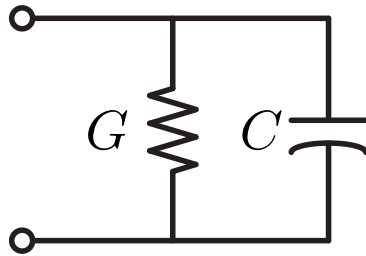

To find the equivalent mean square noise voltage of an RC circuit, begin by calculating the impedance

$$Z = \frac{1}{Y} = \frac{1}{G + j\omega C} = \frac{G - j\omega C}{G^2 + \omega^2 C^2}$$

- Integrating the noise over all frequencies, we have

$$\overline{v_n^2} = \frac{4kT}{2\pi} \int_0^\infty \frac{G}{G^2 + \omega^2 C^2} d\omega = \frac{kT}{C}$$

- Notice the result is *independent* of R . Since the noise and BW is proportional/inversely proportional to R , its influence cancels out

Noise of a Receiving Antenna

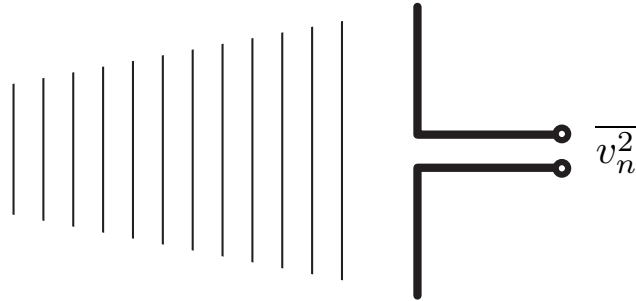

- Assume we construct an antenna with ideal conductors so $R_{wire} = 0$
- If we connect the antenna to a spectrum analyzer, though, we will observe noise
- The noise is also “white” but the magnitude depends on where we point our antenna (sky versus ground)

Equivalent Antenna Temperature

$$\overline{v_a^2} = 4kT_A R_{rad} B$$

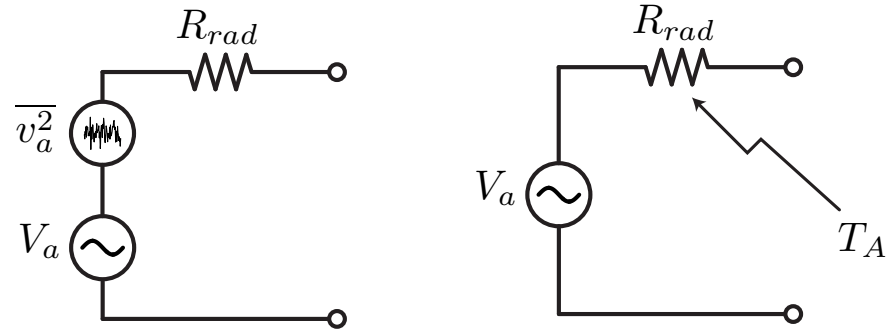

- T_A is the equivalent antenna temperature and R_{rad} is the radiation resistance of the antenna
- Since the antenna does not generate any of its own thermal noise, the observed noise must be incident on the antenna. In fact, it's “black body” radiation.
- Physically T_A is related to the temperature of the external bodies radiating into space (e.g. space or the ground)

Diode Shot Noise

- A forward biased diode exhibits noise called *shot noise*. This noise arises due to the quantized nature of charge.
- The noise mean square current is given by

$$\overline{i_{d,n}^2} = 2qI_{DC}B$$

- The noise is white and proportional to the DC current I_{DC}
- Reversed biased diodes exhibit excess noise not related to shot noise.

Noise in a BJT

- All physical resistors in a BJT produce noise (r_b, r_e, r_c). The output resistance r_o , though, is *not* a physical resistor. Likewise, r_π , is not a physical resistor. Thus these resistances do not generate noise
- The junctions of a BJT exhibit shot noise

$$\overline{i_{b,n}^2} = 2qI_B B$$

$$\overline{i_{c,n}^2} = 2qI_C B$$

- At low frequencies the transistor exhibits “Flicker Noise” or $1/f$ Noise.

BJT Hybrid- Π Model

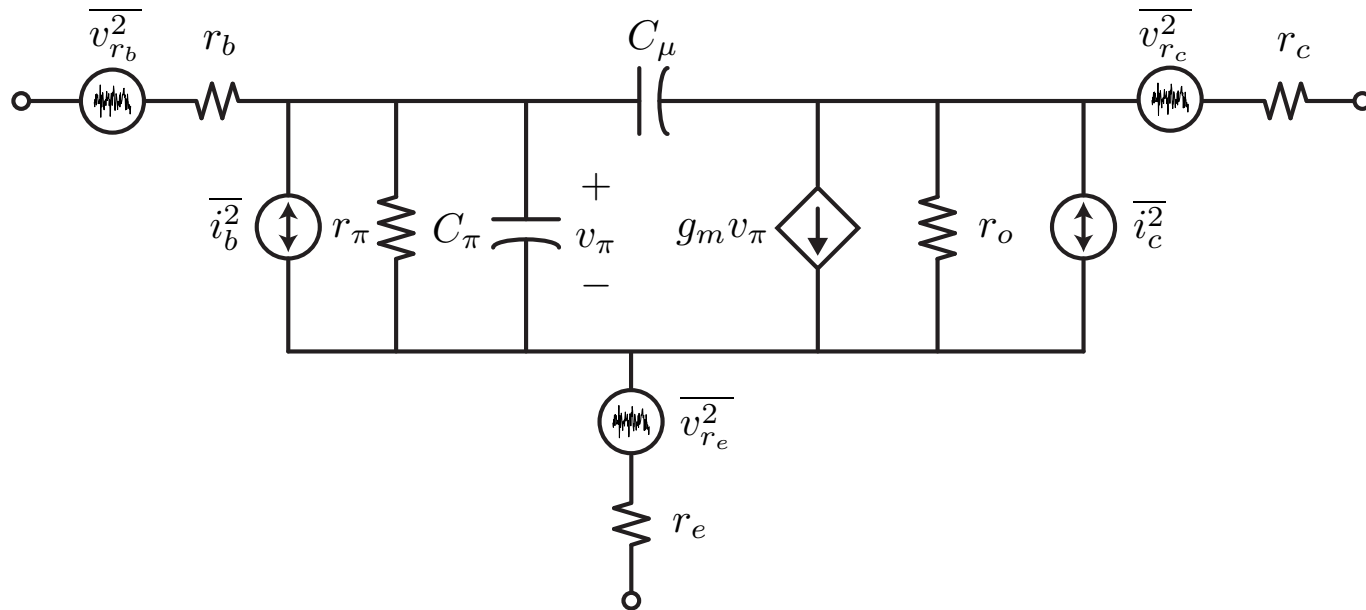

- The above equivalent circuit includes noise sources. Note that a small-signal equivalent circuit is appropriate because the noise perturbation is very small

FET Noise

- In addition to the extrinsic physical resistances in a FET (r_g, r_s, r_d), the channel resistance also contributes thermal noise
- The drain current noise of the FET is therefore given by

$$\overline{i_{d,n}^2} = 4kT\gamma g_{ds0}\delta f + K \frac{I_D^a}{C_{ox}L_{eff}^2 f^e} \delta f$$

- The first term is the thermal noise due to the channel resistance and the second term is the “Flicker Noise”, also called the $1/f$ noise, which dominates at low frequencies.
- The factor $\gamma = \frac{2}{3}$ for a long channel device.
- The constants $K, a,$ and e are usually determined empirically.

FET Channel Resistance

- Consider a FET with $V_{DS} = 0$. Then the channel conductance is given by

$$g_{ds,0} = \frac{\partial I_{DS}}{\partial V_{DS}} = \mu C_{ox} \frac{W}{L} (V_{GS} - V_T)$$

- For a long-channel device, this is also equal to the device transconductance g_m in saturation

$$g_m = \frac{\partial I_{DS}}{\partial V_{GS}} = \mu C_{ox} \frac{W}{L} (V_{GS} - V_T)$$

- For short-channel devices, this relation is not true, but we can define

$$\alpha = \frac{g_m}{g_{d0}} \neq 1$$

FET Noise Equivalent Circuit

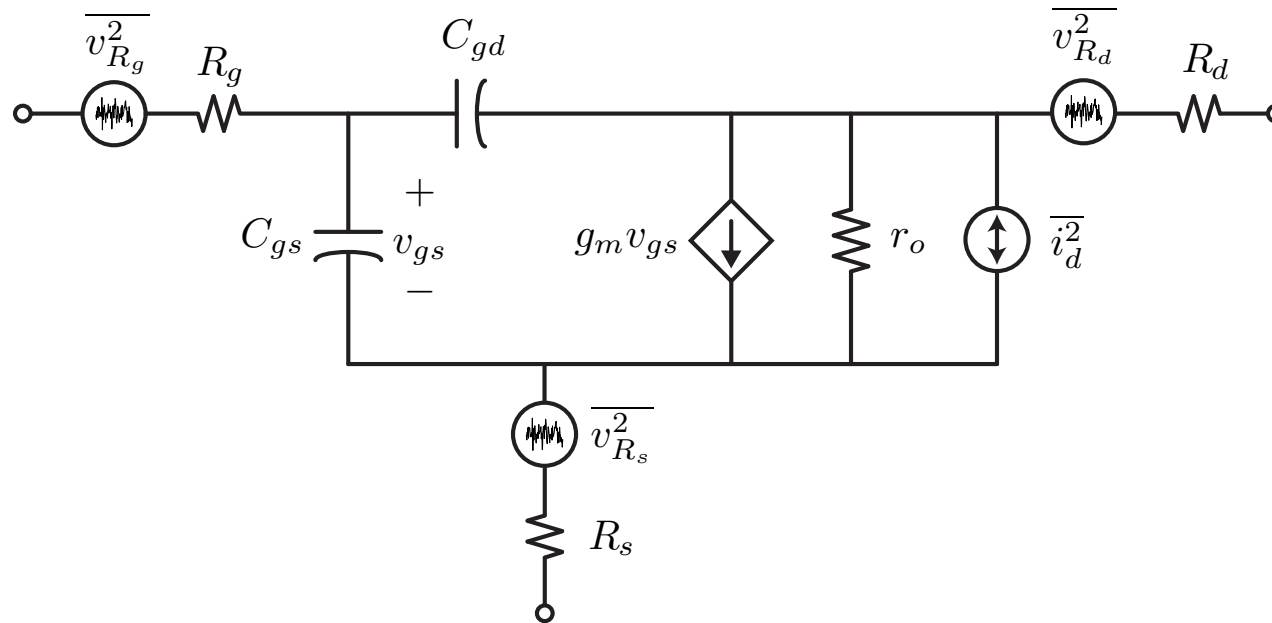

- The resistance of the substrate also generates thermal noise. In most circuits we will be concerned with the noise due to the channel $\overline{i_d^2}$ and the input gate noise $\overline{v_{R_g}^2}$