

## *Lecture 11: Intercept Point, Gain Compression and Blocking*

Prof. Ali M. Niknejad

University of California, Berkeley

Copyright © 2008 by Ali M. Niknejad

# Gain Compression

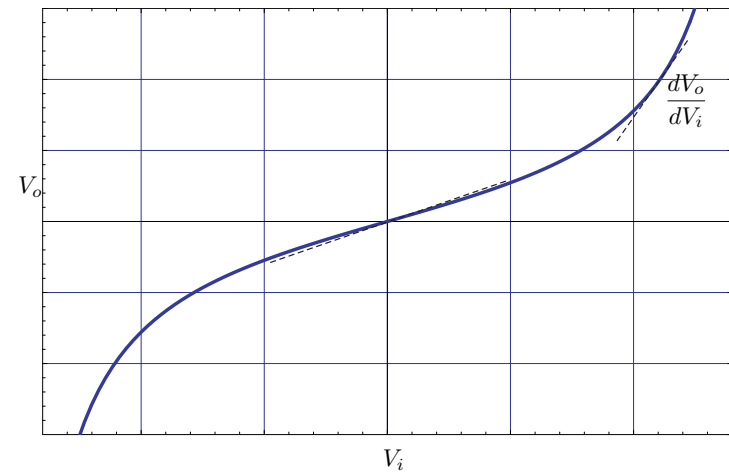
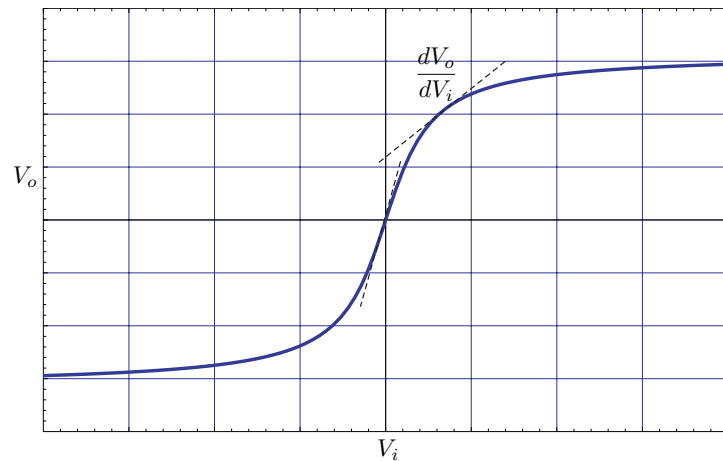

- The large signal input/output relation can display gain compression or expansion. Physically, most amplifiers experience gain compression for large signals.
- The small-signal gain is related to the slope at a given point. For the graph on the left, the gain decreases for increasing amplitude.

# 1 dB Compression Point

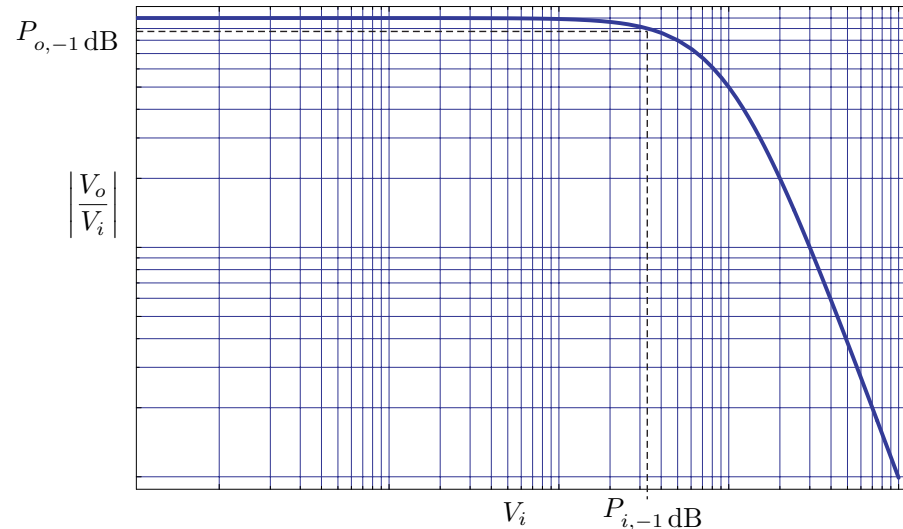

- Gain compression occurs because eventually the output signal (voltage, current, power) limits, due to the supply voltage or bias current.
- If we plot the gain (log scale) as a function of the input power, we identify the point where the gain has dropped by 1 dB. This is the 1 dB compression point. It's a very important number to keep in mind.

# Apparent Gain

- Recall that around a small deviation, the large signal curve is described by a polynomial

$$s_o = a_1 s_i + a_2 s_i^2 + a_3 s_i^3 + \dots$$

- For an input  $s_i = S_1 \cos(\omega_1 t)$ , the cubic term generates

$$\begin{aligned} S_1^3 \cos^3(\omega_1 t) &= S_1^3 \cos(\omega_1 t) \frac{1}{2} (1 + \cos(2\omega_1 t)) \\ &= S_1^3 \left( \frac{1}{2} \cos(\omega_1 t) + \frac{2}{4} \cos(\omega_1 t) \cos(2\omega_1 t) \right) \end{aligned}$$

- Recall that  $2 \cos a \cos b = \cos(a + b) + \cos(a - b)$

$$= S_1^3 \left( \frac{1}{2} \cos(\omega_1 t) + \frac{1}{4} (\cos(\omega_1 t) + \cos(3\omega_1 t)) \right)$$

# Apparent Gain (cont)

- Collecting terms

$$= S_1^3 \left( \frac{3}{4} \cos(\omega_1 t) + \frac{1}{4} \cos(3\omega_1 t) \right)$$

- The apparent gain of the system is therefor

$$G = \frac{S_{o,\omega_1}}{S_{i,\omega_1}} = \frac{a_1 S_1 + \frac{3}{4} a_3 S_1^3}{S_1}$$

$$= a_1 + \frac{3}{4} a_3 S_1^2 = a_1 \left( 1 + \frac{3}{4} \frac{a_3}{a_1} S_1^2 \right) = G(S_1)$$

- If  $a_3/a_1 < 0$ , the gain compresses with increasing amplitude.

# 1-dB Compression Point

- Let's find the input level where the gain has dropped by 1 dB

$$20 \log \left( 1 + \frac{3 a_3}{4 a_1} S_1^2 \right) = -1 \text{ dB}$$

$$\frac{3 a_3}{4 a_1} S_1^2 = -0.11$$

$$S_1 = \sqrt{\frac{4}{3} \left| \frac{a_1}{a_3} \right|} \times \sqrt{0.11} = IIP3 - 9.6 \text{ dB}$$

- The term in the square root is called the third-order intercept point (see next few slides).

# Intercept Point $IP_2$

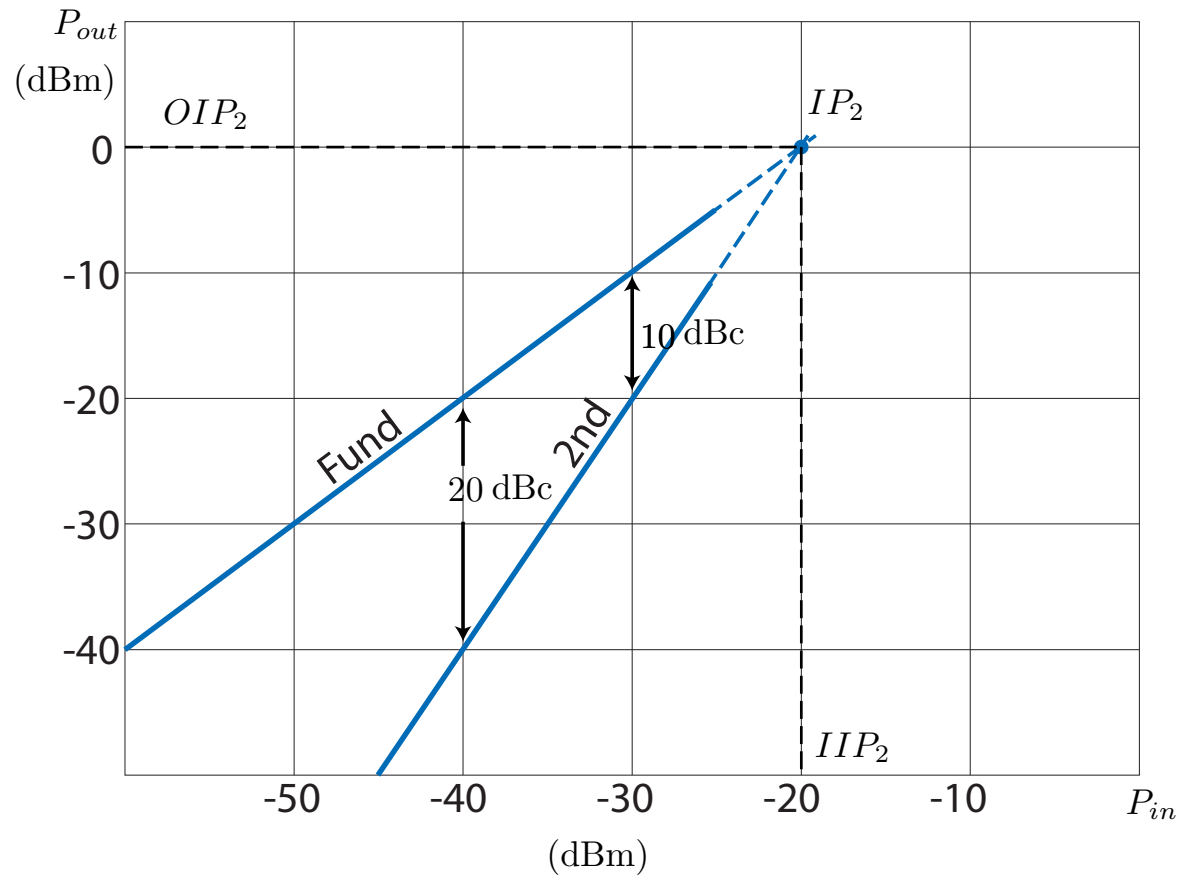

- The extrapolated point where  $IM_2 = 0$  dBc is known as the second order intercept point  $IP_2$ .

# Properties of Intercept Point $IP_2$

- Since the second order IM distortion products increase like  $s_i^2$ , we expect that at some power level the distortion products will overtake the fundamental signal.
- The extrapolated point where the curves of the fundamental signal and second order distortion product signal meet is the Intercept Point ( $IP_2$ ).
- At this point, then, by definition  $IM_2 = 0$  dBc.
- The input power level is known as  $IIP_2$ , and the output power when this occurs is the  $OIP_2$  point.
- Once the  $IP_2$  point is known, the  $IM_2$  at any other power level can be calculated. Note that for a dB back-off from the  $IP_2$  point, the  $IM_2$  improves dB for dB

# Intercept Point $IP_3$

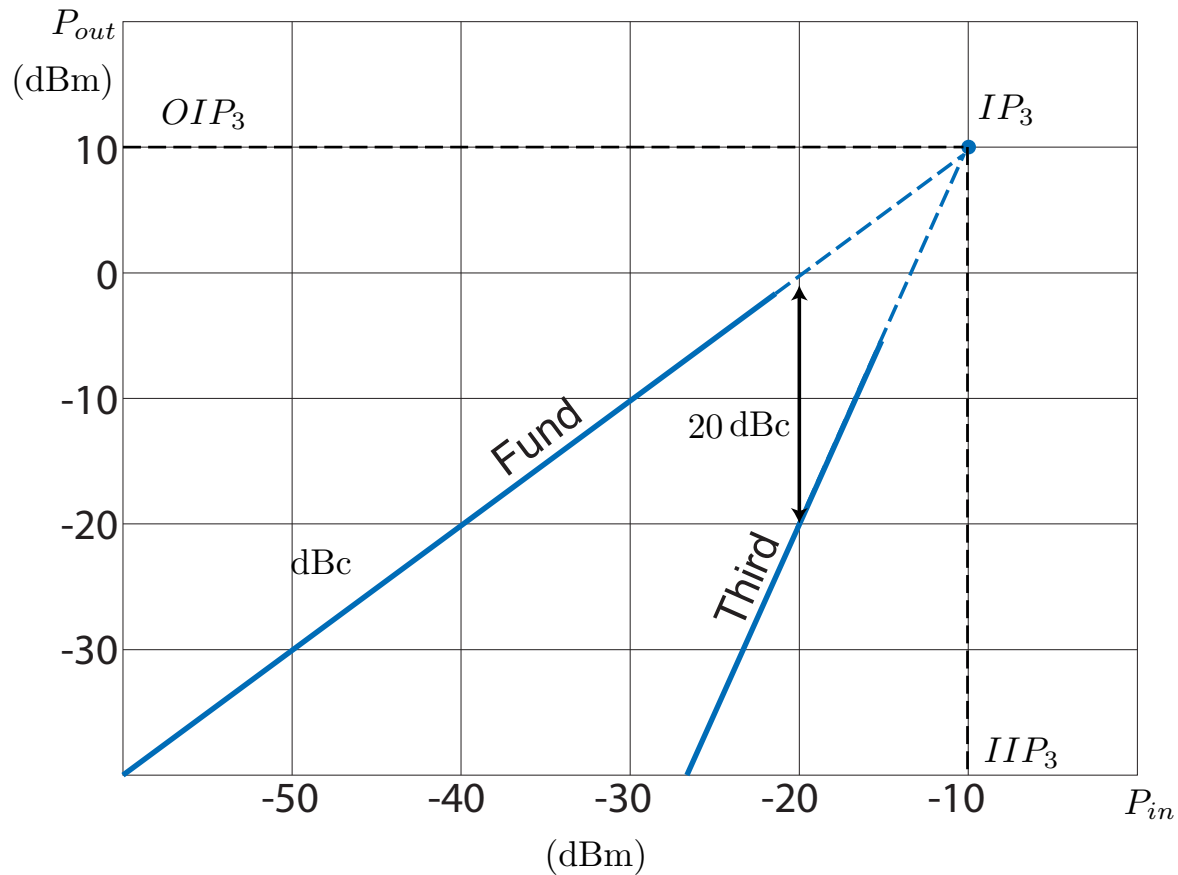

- The extrapolated point where  $IM_3 = 0$  dBc is known as the third-order intercept point  $IP_3$ .

# Properties of Intercept Point $IP_3$

- Since the third order IM distortion products increase like  $s_i^3$ , we expect that at some power level the distortion products will overtake the fundamental signal.
- The extrapolated point where the curves of the fundamental signal and third order distortion product signal meet is the Intercept Point ( $IP_3$ ).
- At this point, then, by definition  $IM_3 = 0$  dBc.
- The input power level is known as  $IIP_3$ , and the output power when this occurs is the  $OIP_3$  point.
- Once the  $IP_3$  point is known, the  $IM_3$  at any other power level can be calculated. Note that for a 10 dB back-off from the  $IP_3$  point, the  $IM_3$  improves 20 dB.

# Intercept Point Example

- From the previous graph we see that our amplifier has an  $IIP_3 = -10$  dBm.
- What's the  $IM_3$  for an input power of  $P_{in} = -20$  dBm?
- Since the  $IM_3$  improves by 20 dB for every 10 dB back-off, it's clear that  $IM_3 = 20$  dBc
- What's the  $IM_3$  for an input power of  $P_{in} = -110$  dBm?
- Since the  $IM_3$  improves by 20 dB for every 10 dB back-off, it's clear that  $IM_3 = 200$  dBc

# Calculated $IIP2/IIP3$

- We can also calculate the  $IIP$  points directly from our power series expansion. By definition, the  $IIP2$  point occurs when

$$IM_2 = 1 = \frac{a_2}{a_1} S_i$$

- Solving for the input signal level

$$IIP_2 = S_i = \frac{a_1}{a_2}$$

- In a like manner, we can calculate  $IIP_3$

$$IM_3 = 1 = \frac{3}{4} \frac{a_3}{a_1} S_i^2 \qquad IIP_3 = S_i = \sqrt{\frac{4}{3} \left| \frac{a_1}{a_3} \right|}$$

# Blocker or Jammer

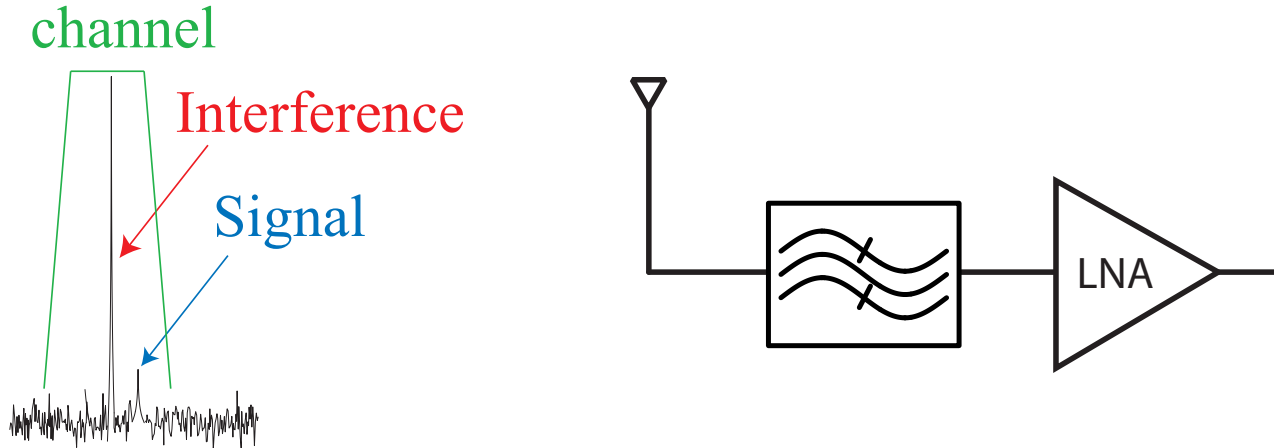

- Consider the input spectrum of a weak desired signal and a “blocker”

$$S_i = \underbrace{S_1 \cos \omega_1 t}_{\text{Blocker}} + \underbrace{s_2 \cos \omega_2 t}_{\text{Desired}}$$

- We shall show that in the presence of a strong interferer, the gain of the system for the desired signal is reduced. This is true even if the interference signal is at a substantially different frequency. We call this interference signal a “jammer”.

# Blocker (II)

- Obviously, the linear terms do not create any kind of desensitization. The second order terms, likewise, generate second harmonic and intermodulation, but not any fundamental signals.
- In particular, the cubic term  $a_3 S_i^3$  generates the jammer desensitization term

$$S_i^3 = S_1^3 \cos^3 \omega_1 t + s_2^3 \cos^3 \omega_2 t + 3S_1^2 s_2 \cos^2 \omega_1 t \cos \omega_2 t + \\ 3s_1^2 S_2 \cos^2 \omega_2 t \cos \omega_1 t$$

- The first two terms generate cubic and third harmonic.
- The last two terms generate fundamental signals at  $\omega_1$  and  $\omega_2$ . The last term is much smaller, though, since  $s_2 \ll S_1$ .

# Blocker (III)

- The blocker term is therefore given by

$$a_3 3S_1^2 s_2 \frac{1}{2} \cos \omega_2 t$$

- This term adds or *subtracts* from the desired signal. Since  $a_3 < 0$  for most systems (compressive non-linearity), the effect of the blocker is to reduce the gain

$$\begin{aligned} \text{App Gain} &= \frac{a_1 s_2 + a_3 \frac{3}{2} S_1^2 s_2}{s_2} \\ &= a_1 + a_3 \frac{3}{2} S_1^2 = a_1 \left( 1 + \frac{3}{2} \frac{a_3}{a_1} S_1^2 \right) \end{aligned}$$

# Out of Band 3 dB Desensitization

- Let's find the blocker power necessary to desensitize the amplifier by 3 dB. Solving the above equation

$$20 \log \left( 1 + \frac{3}{2} \frac{a_3}{a_1} S_1^2 \right) = -3 \text{ dB}$$

- We find that the blocker power is given by

$$P_{OB} = P_{-1} \text{ dB} + 1.2 \text{ dB}$$

- It's now clear that we should avoid operating our amplifier with any signals in the vicinity of  $P_{-1} \text{ dB}$ , since gain reduction occurs if the signals are larger. At this signal level there is also considerable intermodulation distortion.

# Series Inversion

- Often it's easier to find a power series relation for the input in terms of the output. In other words

$$S_i = a_1 S_o + a_2 S_o^2 + a_3 S_o^3 + \dots$$

- But we desire the inverse relation

$$S_o = b_1 S_i + b_2 S_i^2 + b_3 S_i^3 + \dots$$

- To find the inverse relation, we can substitute the above equation into the original equation and equate coefficient of like powers.

$$S_i = a_1 (b_1 S_i + b_2 S_i^2 + b_3 S_i^3 + \dots) + a_2 ( )^2 + a_3 ( )^3 + \dots$$

# Inversion (cont)

- Equating linear terms, we find, as expected, that  $a_1 b_1 = 1$ , or  $b_1 = 1/a_1$ .
- Equating the square terms, we have

$$0 = a_1 b_2 + a_2 b_1^2$$

$$b_2 = -\frac{a_2 b_1^2}{a_1} = -\frac{a_2}{a_1^3}$$

- Finally, equating the cubic terms we have

$$0 = a_1 b_3 + a_2 2b_1 b_2 + a_3 b_1^3 \qquad b_3 = \frac{2a_2^2}{a_1^5} - \frac{a_3}{a_1^4}$$

- It's interesting to note that if one power series does not have cubic,  $a_3 \equiv 0$ , the inverse series has cubic due to the first term above.

# Cascade

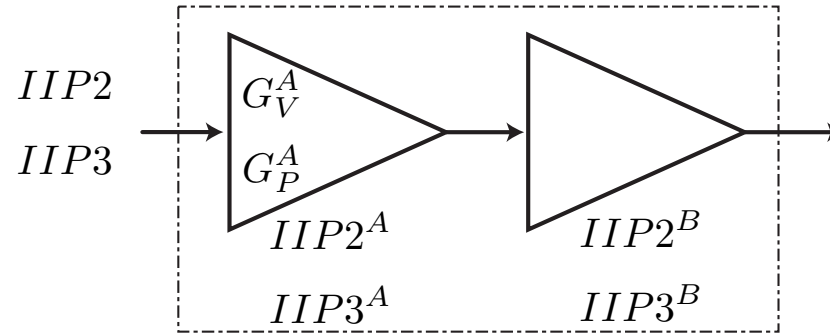

- Another common situation is that we cascade two non-linear systems, as shown above. we have

$$y = f(x) = a_1x + a_2x^2 + a_3x^3 + \dots$$

$$z = g(y) = b_1y + b_2y^2 + b_3y^3 + \dots$$

- We'd like to find the overall relation

$$z = c_1x + c_2x^2 + c_3x^3 + \dots$$

# Cascade Power Series

- To find  $c_1, c_2, \dots$ , we simply substitute one power series into the other and collect like powers.
- The linear terms, as expected, are given by

$$c_1 = b_1 a_1 = a_1 b_1$$

- The square terms are given by

$$c_2 = b_1 a_2 + b_2 a_1^2$$

- The first term is simply the second order distortion produced by the first amplifier and amplified by the second amplifier linear term. The second term is the generation of second order by the second amplifier.

# Cascade Cubic

- Finally, the cubic terms are given by

$$c_3 = b_1 a_3 + b_2 2a_1 a_2 + b_3 a_1^3$$

- The first and last term have a very clear origin. The middle terms, though, are more interesting. They arise due to second harmonic interaction. The second order distortion of the first amplifier can interact with the linear term through the second order non-linearity to produce cubic distortion.
- Even if both amplifiers have negligible cubic,  $a_3 = b_3 \equiv 0$ , we see the overall amplifier can generate cubic through this mechanism.

# Cascade Example

- In the above amplifier, we can decompose the non-linearity as a cascade of two non-linearities, the  $G_m$  non-linearity

$$i_d = G_{m1}v_{in} + G_{m2}v_{in}^2 + G_{m3}v_{in}^3 + \dots$$

- And the output impedance non-linearity

$$v_o = R_1i_d + R_2i_d^2 + R_3i_d^3 + \dots$$

- The output impedance can be a non-linear resistor load (such as a current mirror) or simply the load of the device itself, which has a non-linear component.

# IIP2 Cascade

- Commonly we'd like to know the performance of a cascade in terms of the overall  $IIP2$ . To do this, note that  $IIP2 = c_1/c_2$

$$\frac{c_2}{c_1} = \frac{b_1 a_2 + b_2 a_1^2}{b_1 a_1} = \frac{a_2}{a_1} + \frac{b_2}{b_1} a_1$$

- This leads to

$$\frac{1}{IIP2} = \frac{1}{IIP2^A} + \frac{a_1}{IIP2^B}$$

- This is a very intuitive result, since it simply says that we can *input refer* the  $IIP2$  of the second amplifier to the input by the voltage gain of the first amplifier.

# IIP2 Cascade Example

- Example 1: Suppose the input amplifiers of a cascade has  $IIP2^A = +0$  dBm and a voltage gain of 20 dB. The second amplifier has  $IIP2^B = +10$  dBm.
- The input referred  $IIP2_i^B = 10$  dBm  $- 20$  dB =  $-10$  dBm
- This is a much smaller signal than the  $IIP2^A$ , so clearly the second amplifier dominates the distortion. The overall distortion is given by  $IIP2 \approx -12$  dB.
  
- Example 2: Now suppose  $IIP2^B = +20$  dBm. Since  $IIP2_i^B = 20$  dBm  $- 20$  dB =  $0$  dBm, we cannot assume that either amplifier dominates.
- Using the formula, we see the actual  $IIP2$  of the cascade is a factor of 2 down,  $IIP2 = -3$  dBm.

# IIP3 Cascade

- Using the same approach, let's start with

$$\frac{c_3}{c_1} = \frac{b_1 a_3 + b_2 a_1 a_2 2 + b_3 a_1^3}{b_a a_1} = \left( \frac{a_3}{a_1} + \frac{b_3}{b_1} a_1^2 + \frac{b_2}{b_1} 2a_2 \right)$$

- The last term, the second harmonic interaction term, will be neglected for simplicity. Then we have

$$\frac{1}{IIP3^2} = \frac{1}{IIP3_A^2} + \frac{a_1^2}{IIP3_B^2}$$

- Which shows that the  $IIP3$  of the second amplifier is input referred by the voltage gain squared, or the power gain.

# LNA/Mixer Example

- A common situation is an LNA and mixer cascade. The mixer can be characterized as a non-linear block with a given  $IIP2$  and  $IIP3$ .
- In the above example, the LNA has an  $IIP3^A = -10$  dBm and a power gain of 20 dB. The mixer has an  $IIP3^B = -20$  dBm.
- If we input refer the mixer, we have  
$$IIP3_i^B = -20 \text{ dBm} - 20 \text{ dB} = -40 \text{ dBm}.$$
- The mixer will dominate the overall  $IIP3$  of the system.

# Example: Disto in Long-Ch. MOS

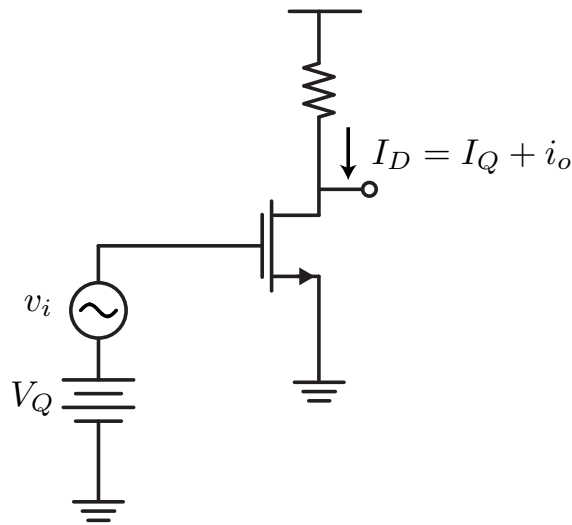

$$I_D = \frac{1}{2} \mu C_{ox} \frac{W}{L} (V_{GS} - V_T)^2$$

$$i_o + I_Q = \frac{1}{2} \mu C_{ox} \frac{W}{L} (V_Q + v_i - V_T)^2$$

- Ignoring the output impedance we have

$$= \frac{1}{2} \mu C_{ox} \frac{W}{L} \{ (V_Q - V_T)^2 + v_i^2 + 2v_i(V_Q - V_T) \}$$

$$= \underbrace{I_Q}_{\text{dc}} + \underbrace{\mu C_{ox} \frac{W}{L} v_i (V_Q - V_T)}_{\text{linear}} + \underbrace{\frac{1}{2} \mu C_{ox} \frac{W}{L} v_i^2}_{\text{quadratic}}$$

# Ideal Square Law Device

- An ideal square law device only generates 2nd order distortion

$$i_o = g_m v_i + \frac{1}{2} \mu C_{ox} \frac{W}{L} v_i^2$$

$$a_1 = g_m$$

$$a_2 = \frac{1}{2} \mu C_{ox} \frac{W}{L} = \frac{1}{2} \frac{g_m}{V_Q - V_T}$$

$$a_3 \equiv 0$$

- The harmonic distortion is given by

$$HD_2 = \frac{1}{2} \frac{a_2}{a_1} v_i = \frac{1}{4} \frac{g_m}{V_Q - V_T} \frac{1}{g_m} v_i = \frac{1}{4} \frac{v_i}{V_Q - V_T}$$

$$HD_3 = 0$$

# Real MOSFET Device

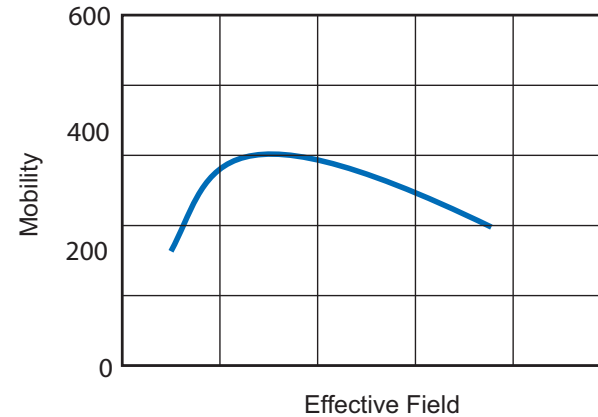
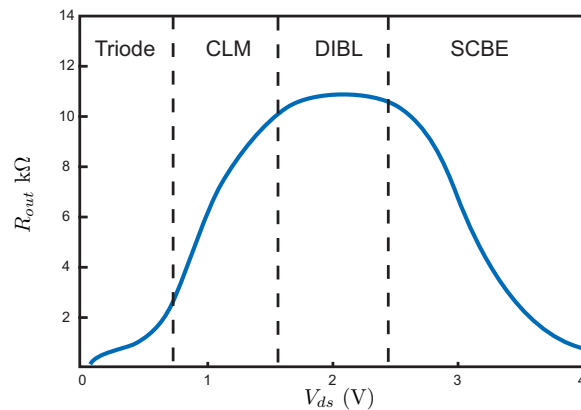

- The real MOSFET device generates higher order distortion
- The output impedance is non-linear. The mobility  $\mu$  is not a constant but a function of the vertical and horizontal electric field
- We may also bias the device at moderate or weak inversion, where the device behavior is more exponential
- There is also internal *feedback*