

EECS 242

Topic: Two-Port Noise

Prof. Niknejad

University of California, Berkeley

Noise Figure Review

- Recall that the noise figure of a two-port is defined by

$$F = \frac{P_{N_s} + P_{N_a}}{P_{N_s}} = 1 + \frac{P_{N_a}}{P_{N_s}}$$

- In the above equation P_{N_s} is the noise due to the source resistance whereas P_{N_a} is the noise added to the signal by the amplifier. Since $P_{N_a} \geq 0$ for any two-port, the noise figure $F \geq 1$.
- A noiseless system has $F = 1$. For instance, a two-port consisting of ideal L 's and C 's (lossless) has an $F = 1$.
- If a *matched* two-port has loss, then the noise figure is equal to the loss. To see this, we use the following equivalent formulation

$$F = \frac{P_{sig}(P_{N_s} + P_{N_a})}{P_{sig}P_{N_s}} = \frac{P_{sig}}{P_{N_s}} \frac{P_{N_s} + P_{N_a}}{P_{sig}} = \frac{SNR_i}{SNR_o}$$

- Thus we recall that F (dB) can also be interpreted as the *decrease* in SNR as a result of the two-port.
- Thus, for a constant noise floor (or equal system resistance) any reduction in the signal adds to the F dB for dB.

Noise Figure and Input/Output Reference

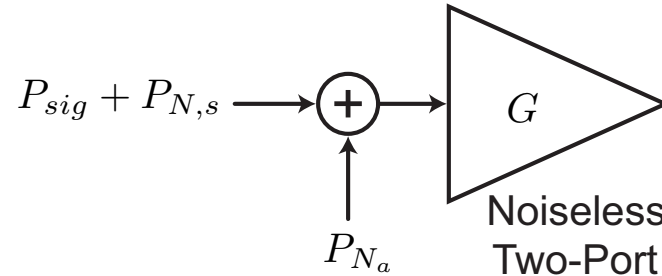

- While the noise of a two-port originates from *inside* the two-port, it's convenient to pretend that the two-port is noiseless and to imagine that the noise is added to either the input or output of the amplifier.
- The input referred noise is more commonly used. Also, the noise power is used in the above equations, not the noise voltage or current. From circuit theory, we can take any two-port and simplify it to a noiseless two-port with an input referred voltage and current. In general, the voltage and current are correlated.
- The total input noise can be derived from the definition of F

$$F - 1 = \frac{P_{N_a}}{P_{N_s}}$$

$$P_{N_a} = P_{N_s} (F - 1)$$

Cascade Noise Figure

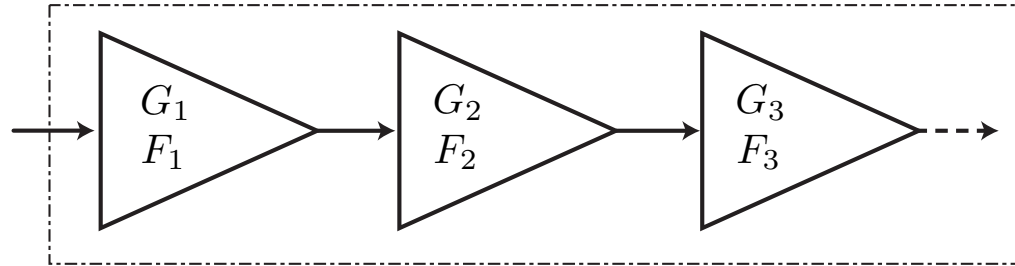

- If several amplifier stages or two-ports are connected in cascade, we wish to know the overall noise figure. We can use the concept of a noiseless two-port cascade and simply input refer all the noise sources.
- The noise from the second stage can be input referred if the power gain is known and the stages are matched

$$P_{N_{ia,2}} = \frac{P_{N_s} (F_2 - 1)}{G_1}$$

- The noise from the k 'th stage can be similarly input referred

$$P_{N_{ia,k}} = \frac{P_{N_s} (F_k - 1)}{G_1 \cdot G_2 \cdots G_{k-1}}$$

Cascade Noise Figure (cont)

- Therefore the total noise figure is given by

$$F = F_1 + \frac{F_2 - 1}{G_1} + \frac{F_3 - 1}{G_1 G_2} + \dots$$

- The above formula is very important as it highlights the importance of the first stage of the cascade. The overall noise figure of the cascade is bounded by the noise of the first stage whereas the noise figure of other stages is divided by the gain preceding the stage.
- The first stage amplifier, or the *low noise amplifier* (LNA), is thus one of the most important blocks in a microwave receiver. The noise of the first stage must be as low as possible and the gain as high as possible in order to reject the subsequent noise in the system, especially the mixer (which tends to have a high noise figure).
- Any attenuation before the LNA must be minimized (cables, mismatch, loss in filters, switches, and diplexers).

Noise Voltage/Current

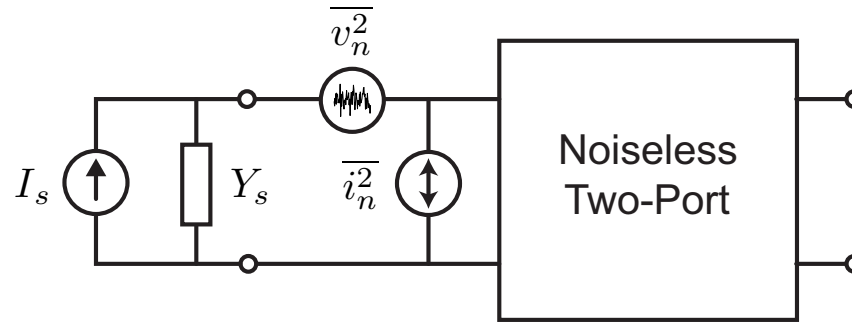

- Let's calculate the noise figure of a general two-port shown above. The total input current into the device is easily calculated by superposition

$$i_i = \frac{Y_{in}}{Y_{in} + Y_s} i_s + \frac{Y_{in}}{Y_{in} + Y_s} i_n + \frac{1}{Z_{in} + Z_s} v_n$$

- Here we have added noise currents and voltages as if they were deterministic signals. We need to exercise caution when computing the power entering the two by carefully considering the correlation among the sources.
- The above expression can be simplified by noting that

$$\frac{1}{Z_{in} + Z_s} v_n = \frac{Y_{in}}{Y_s + Y_{in}} Y_s v_n$$

Input Noise Power

- The total noise current is thus given by

$$i_i = \frac{Y_{in}}{Y_{in} + Y_s} (i_s + i_n + Y_s v_n)$$

- Now the total input RMS power is proportional to $\overline{i_i^2} \Re(Z_{in})$, and the ratio of powers can be written simply

$$F = \frac{\overline{i_i^2}}{\overline{i_i^2} \Big|_{i_n=0, v_n=0}} = 1 + \frac{\overline{(i_n + Y_s v_n)^2}}{\overline{i_s^2}}$$

- The last equality follows from the fact that the source noise is independent of the two-port noise.
- It's fruitful to now express the input current i_n as a sum of two part, a part uncorrelated from v_n called i_u and a part that is correlated i_c

$$i_n = i_u + Y_C v_n$$

- The admittance Y_C is called the correlation admittance.

Two-Port Noise Figure (cont)

- With the above substitution, we have

$$= 1 + \frac{\overline{(i_u + (Y_C + Y_s)v_n)^2}}{\overline{i_s^2}}$$

- But now by the fact that the numerator terms are independent by design

$$= 1 + \frac{\overline{i_u^2} + |Y_C + Y_s|^2 \overline{v_n^2}}{\overline{i_s^2}}$$

- Let $v_n = 4kTR_n$ and $i_u = 4kTG_n$ so that we can express the above in the following form

$$F = 1 + \frac{G_n}{G_s} + \frac{R_n}{G_s} |Y_C + Y_s|^2$$
$$= 1 + \frac{G_n}{G_s} + \frac{R_n}{G_s} ((G_C + G_s)^2 + (B_C + B_s)^2)$$

Noise Optimum Source Admittance

- For a power match we know that the optimum source impedance is given by Y_{in}^* . But as we shall see, this is not necessarily the optimum source impedance if we wish to minimize the noise figure.
- The optimum is easily found by taking partials of F . In particular note that the minimum F as a function of B_s is given by $-B_C$. In terms of G_s

$$\frac{\partial F}{\partial G_s} = -\frac{G_u}{G_s^2} + \frac{R_n}{G_s} 2(G_C + G_s) - \frac{(G_C + G_s)^2 R_n}{G_s^2} = 0$$

- The solution exists can be shown to correspond to a minima

$$G_{s,opt} = \sqrt{G_C^2 + \frac{G_u}{R_n}}$$

$$B_{s,opt} = -B_C$$

- Note that in general $Y_{S,opt} \neq Y_{in}^*$ and thus the noise match does not correspond to the gain match, and thus a compromise is necessary to find the best performance.

F_{min}

- The minimum achievable noise figure is given by

$$F_{min} = 1 + 2G_C R_n + 2\sqrt{R_n G_u + (R_n G_C)^2}$$

- Note that F_{min} can be attained with a unique choice $Y_{s,opt}$. With some algebraic manipulations, it can be shown that for any other source admittance

$$F = F_{min} + \frac{R_n}{G_s} |Y_s - Y_{s,opt}|^2$$

- The noise figure increases proportional to the distance squared between the optimum source impedance and a given source impedance. The proportionality factor is a property of the transistor R_n/G_s . A transistor with a small R_n is thus desirable.
- Also note that at a single frequency, the two-port noise property of a device is completely characterized by four numbers, $Y_{s,opt}$, R_n and F_{min} .

Source Reflection Representation

- To plot the noise figure on the Smith Chart (to compare to gain circles), it's desirable to represent the noise in terms of the source reflection coefficient

$$\begin{aligned} |Y_S - Y_{opt}|^2 &= \left| \frac{1 - \Gamma_S}{1 + \Gamma_S} - \frac{1 - \Gamma_{opt}}{1 + \Gamma_{opt}} \right|^2 Y_0^2 \\ &= \left| \frac{(1 - \Gamma_S)(1 + \Gamma_{opt}) - (1 - \Gamma_{opt})(1 + \Gamma_S)}{(1 + \Gamma_S)(1 + \Gamma_{opt})} \right|^2 Y_0^2 \end{aligned}$$

- Simplifying the numerator, we have

$$\begin{aligned} &= 4Y_0^2 \frac{|\Gamma_{opt} - \Gamma_S|^2}{|1 + \Gamma_S|^2 |1 + \Gamma_{opt}|^2} \\ G_S = \Re(Y_S) &= \frac{1}{2}(Y_S + Y_S^*) = \frac{1}{2}Y_0 \left(\frac{1 - \Gamma_S}{1 + \Gamma_S} + \frac{1 - \Gamma_S^*}{1 + \Gamma_S^*} \right) \\ &= \frac{1}{2} \frac{(1 - \Gamma_S)(1 + \Gamma_S^*) + (1 - \Gamma_S^*)(1 + \Gamma_S)}{|1 + \Gamma_S|^2} = Y_0 \frac{1 - |\Gamma_S|^2}{|1 + \Gamma_S|^2} \end{aligned}$$

Transformed F_{min} Equation

- With these substitutions, we have

$$F = F_{min} + \frac{4R_n Y_0 |\Gamma_{opt} - \Gamma_S|^2}{(1 - |\Gamma_S|^2) |1 + \Gamma_{opt}|^2}$$

- Does this look like a circle? We will next show that for a fixed value of F , this is an equation for a circle in the Γ plane. Collect all terms that are constant for fixed F

$$N = \frac{F - F_{min}}{4R_n Y_0} |1 + \Gamma_{opt}|^2$$

- With this definition, the equation simplifies to

$$N = \frac{|\Gamma_S - \Gamma_{opt}|^2}{1 - |\Gamma_S|^2}$$

$$N(1 - |\Gamma_S|^2) = (\Gamma_S - \Gamma_{opt})(\Gamma_S^* - \Gamma_{opt}^*)$$

$$N(1 - |\Gamma_S|^2) = \Gamma_S^2 - (\Gamma_{opt}\Gamma_S^* + \Gamma_{opt}^*\Gamma_S) - \Gamma_{opt}^2$$

$$|\Gamma_S|^2(N + 1) - (\Gamma_{opt}\Gamma_S^* + \Gamma_{opt}^*\Gamma_S) - |\Gamma_{opt}|^2 - N = 0$$

Noise Circles

- Completing the square ...

$$|\Gamma_S|^2 - \frac{1}{N+1}(\Gamma_{opt}\Gamma_S^* + \Gamma_{opt}^*\Gamma_S) + \frac{|\Gamma_{opt}|^2}{(N+1)^2} = \frac{|\Gamma_{opt}|^2 + N}{N+1} + \frac{|\Gamma_{opt}|^2}{(N+1)^2}$$

$$\left| \Gamma_S - \frac{\Gamma_{opt}}{N+1} \right| = \frac{\sqrt{N(N+1 - |\Gamma_{opt}|^2)}}{N+1}$$

- The noise circles are centered at $\Gamma_{opt}/(N+1)$ with radius given by the right hand side. Note that, as expected, the optimum noise figure is a point centered at Γ_{opt} with radius zero ($N = 0$).

BJT Amplifier Example

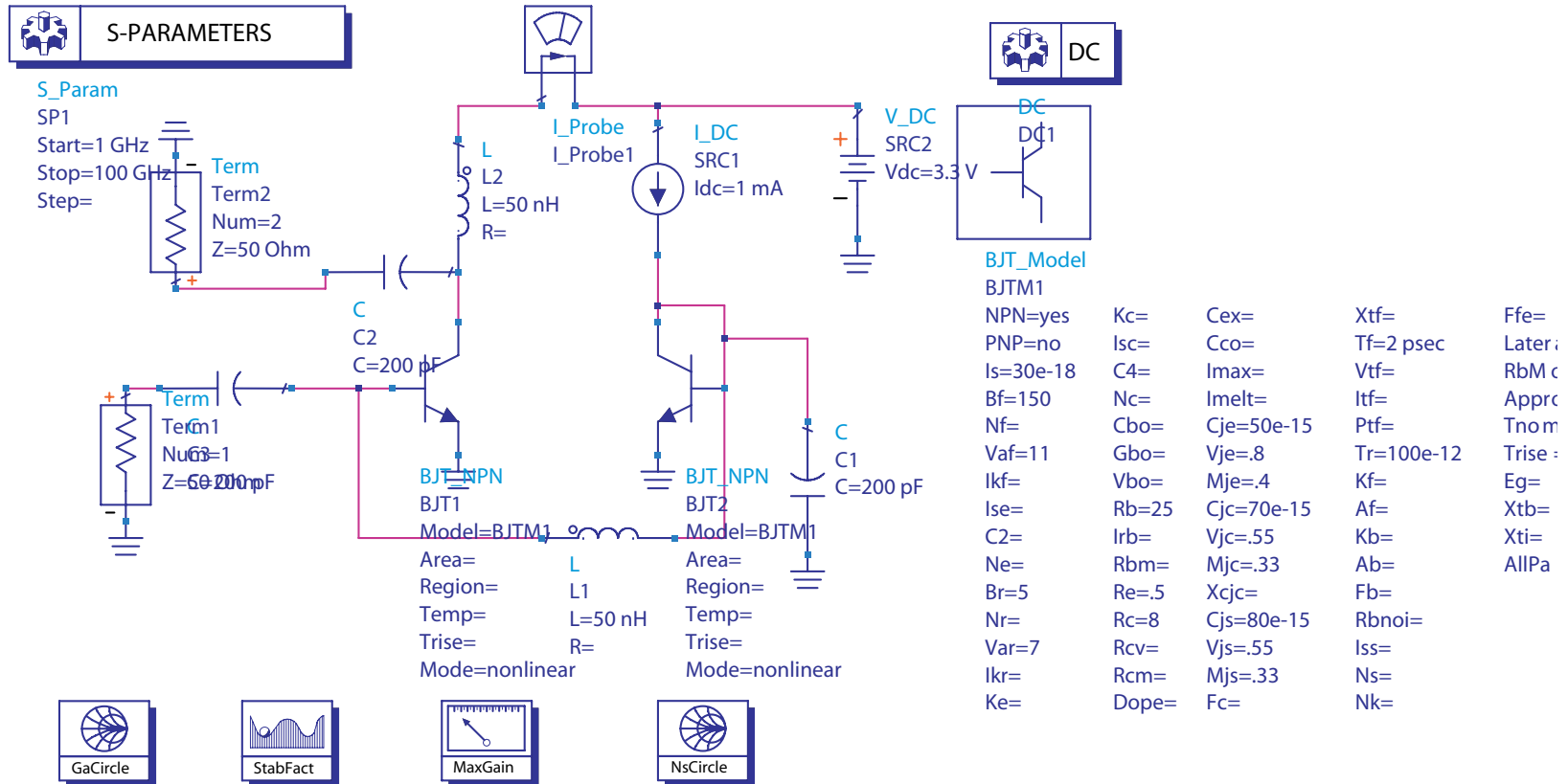

- A BJT device in common emitter configuration is shown above.
- The simulation setup will calculate the S parameters, noise figure, and available gain circles.

MSG/NF_{min}

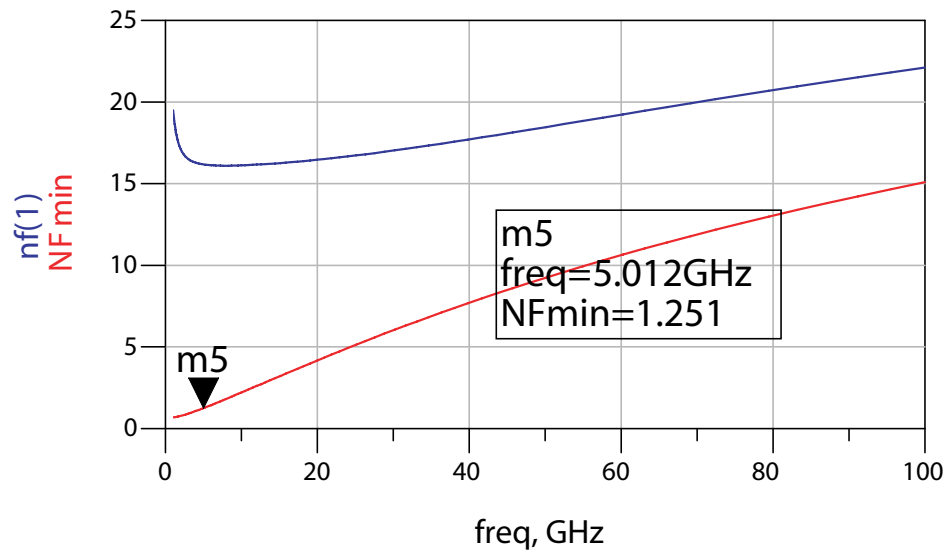
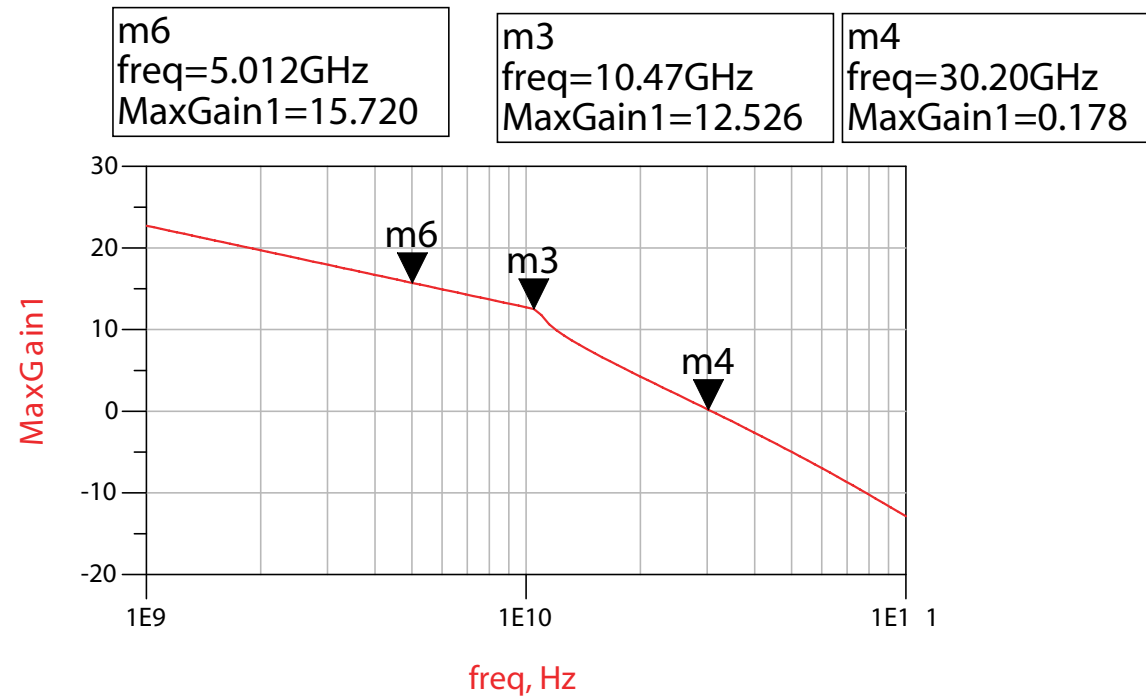

Noise/Gain Circles

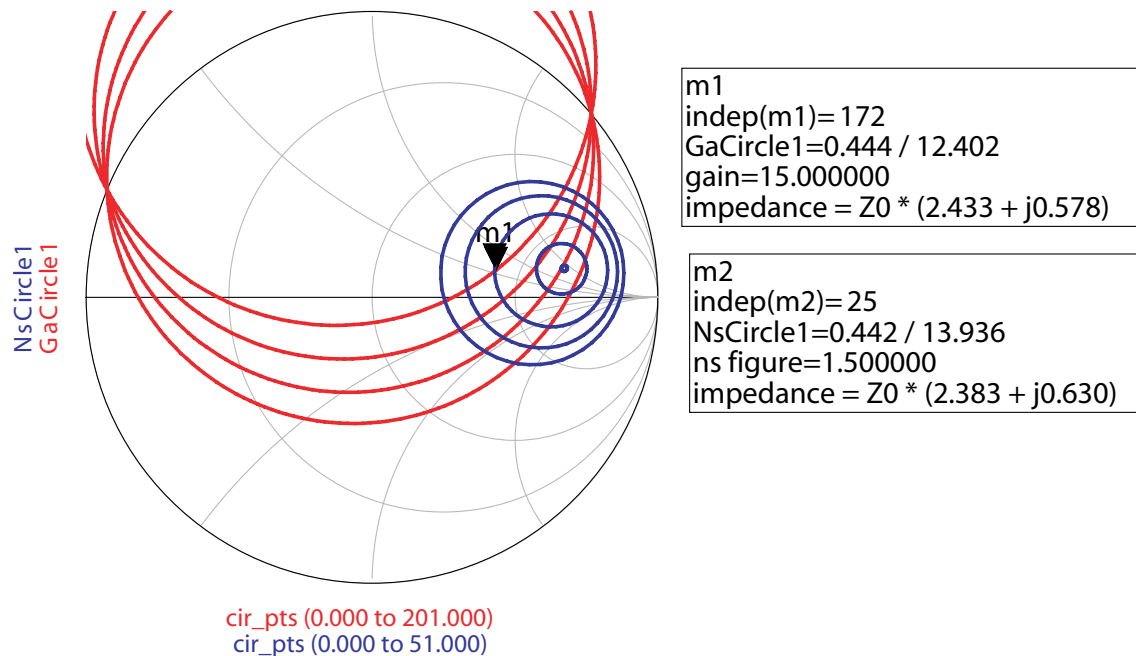

- A plot of the maximum stable gain (MSG), $NF_{50 \Omega}$, and NF_{min} is shown above.
- Note the f_{max} is around 30GHz with about 15.7dB stable gain at 5GHz. The minimum achievable noise figure is about 1.25dB but the 50Ω noise figure is considerably higher.
- What is the best achievable noise/gain trade-off? By plotting the available gain circles G_A along with the noise figure circles, we can choose an appropriate point to achieve a reasonable trade-off. For instance, the $G_A = 15\text{dB}$ circle intersects the $NF = 1.5\text{dB}$ circle when the source impedance is $Z_S = Z_0(2.4 + j0.6)$.